

43

November
1986

elektor

INDIA

Rs. 7.50

electronics

COMPUTERSCOPE



**Gallium-arsenide vs silicon: the future
Converter for satellite TV reception
Air defence systems**

Introducing **uranus**

India's first complete microcomponent music system with the latest international all-black looks. And upgraded features no other single music system offers.



With so many music systems around, any new arrival must have something more to offer Uranus does. It has a lot of unique features. Some of which only the most advanced music systems in the world offer.

To begin with, Uranus has leather-touch controls. Brightly lit LED indicators that give the all-clear signal. Dolby® B in the deck that kills tape hiss. A rugged, soft-touch tape mechanism to ensure impeccable performance. A hard permalloy head for longer life and metal-tape compatibility. And a mike socket for live recordings.

There's an amplifier with 200 watts (PMPO) of electrifying music power. Hi-filter to hush up disturbances. Loudness control to heighten listening pleasure at low levels. And a tape monitor to help

check the quality of music you're recording.

Then there's an AM/FM stereo tuner for music around the world. A 12-band graphic equalizer that lets you engineer your own sound. A sleek, belt-driven, automatic turntable. And best of all, India's hottest selling SX-606 bass reflex speaker system that unleashes rich, pure, dreamy sound.

So even if you're tempted to buy Uranus for its looks alone, do give it a hearing. After all, what's really stunning about it is its sound. The sound of Sonodyne.

Uranus is a totality of the SD-520 cassette deck, SA-520 stereo integrated amplifier, ST-500 stereo tuner, SQ-500 graphic equalizer, SP-500 turntable and SX-606 speaker system.

* Dolby is the registered trademark of Dolby Laboratories Licensing Corporation.

SONODYNE **uranus**

Sensational... even when it's quiet.

Publisher: C R Chandrana
 Editor: Surendra Iyer
 Editorial Assistance: Ashok Dongre
 General Manager: J Dhas
 Advertising: B M Mahle
 Production: C N Mahagan

Address
 ELEKTOR ELECTRONICS PVT LTD
 52, C Proctor Road
 Bombay - 400 007 INDIA
 Telex (011) 76661 ELEK IN

Overseas editions

Elektor Electronics
 Standlast House
 Bath Place
 High Street, Baines
 Herts EN5 5XE U K
 Editor: Len Seymour

Publiron Publicações Técnicas Ltda
 Av Ipiranga 1100, 9º andar
 CEP 01040 Sao Paulo -- Brazil
 Editor: Juliano Barselli

Elektor sail
 Route Nationale, Le Seau; B P 53
 58270 Bailleul -- France
 Editors: D R S Meyer,
 G C P Raedersdorf

Elektor Verlag GmbH
 Susterfeld Straße 25
 100 Aachen -- West Germany
 Editor: E J A Krempelsauer

Elektor EPE
 Kariaskaki 14
 15673 Voula -- Athens Greece
 Editor: E Xanihouli

Elektuur B V
 Parel Tiekpoelstraat 24
 6191 VK Beek -- the Netherlands
 Editor: P E L Kensemekers

Ferreira & Bento Lda
 R D Estefana, 32 1º
 1000 Lisboa -- Portugal
 Editor: Jorge Goncalves

Ingelek S A
 Av Alfonso XIII, 141
 Madrid 36 Spain
 Editor: A M Ferrer

In pelt
 Kedhoon Holdings PTY Ltd
 Cnr Fox Valley Road &
 Kogile Street
 Wahsoonga NSW 2076 Australia
 Editor: Roger Herrison

Elektor Press AB
 Box 63
 182 11 Danderyd Sweden
 Editor: Bill Cedarius

The Circuits are for domestic use only.
 The submission of designs of articles of
 Elektor India implies permission to the
 publishers to alter and translate the text
 and designed to use the contents in
 other Elektor publications and countries.
 The publishers cannot guarantee to
 return any material submitted to them.
 All drawings, photographs, printed
 circuit boards and articles published in
 Elektor India are copyright and may not
 be reproduced or imitated in whole or
 part without prior written permission of
 the publishers.

Patents protection may exist in respect of
 circuits, devices, components etc
 described in this magazine.

The publishers do not accept
 responsibility for failing to identify such
 patents or other protection.

Contributors
 Elektor Publishers & Distributors Pvt Ltd

Printed At
 Tripathi Offset
 Bombay 400 013



Copyright © 1986 Elektuur B V
 The Netherlands



Volume-4 Number - 11
 November - 1986

Electronics technology

Air defence systems for countries and continents	11.23
Jockeying for supremacy in Europe's own space race	11.36
How much longer will silicon be used?	11.40

Projects

Computerscope - 1	11.18
Voltage comparison on a scope	11.25
IDU for satellite TV reception - 1	11.26
RF circuit design	11.38
Dark-room exposure meter	11.44
High-power AF amplifier - 2	11.46

Information

News and views ..	11-16
New products	11.62
Corrections	11.74

Guide lines

Classified ads ..	11.74
Index of advertisers ..	11.74

Selax - 17

Measuring Techniques (chapter-3)	11.66
Measuring power with a Multimeter	11.67
Power Calculations	11.60

YOUR SEARCH IS OVER
FOR SOLDER WIRES & STICKS



SWASTIK

a name synonymous with good quality

- Low melting point
- Minimum resistance
- No dry solder
- Reasonably priced



MANUFACTURED BY

Swastik Smelting Co

205-B Shreyas Industrial Estate
Off Western Express Highway, Goregaon (E)
Bombay - 400 063 Ph 68 45 37

Shiv Shakti Enterprises

C-1B/9101/4, GIDC Industrial Estate
Halol - 389350, Dist. Panchmahal
GUJRAT - Ph 708

— STOCKISTS —

**Precious
Electronics Corporation**

52, C Proctor Road (Grant Road (E))
Bombay 400007
Ph. 367459, 369478

**Apex Electronics
(Bombay) Pvt. Ltd.**

Ganesh Nivas, 11 Tara Temple Lane
Bombay-400 007
Ph 36 35 92/35 65 29

Shaktee Electronics

Amrut Bazar Shop No. 1, 12 Kiln Lane
Bombay-400 007
Ph Shop 359493, Resi 54 70 10

Rupani Parts Centre

12, Arun Bazar, S V Road,
Malad (West)
Bombay-400 064, Ph 682720

Aress Electronics

366, Lamington Rd., Ahmed Mansion,
1st Floor, Bombay-400 007,
Ph - Resi - 651793



PHILIPS

Now world class polypropylene capacitors with the unmistakable stamp of Philips excellence

Capacitors are intended for applications where high current, high voltages and steep pulses occur. They are mainly used for deflection circuits in television receivers, for commutation in thyristor circuits and pulse steepness suppression networks.

Specifications

Rated capacitance	1500 pF — 0.82 μ F
Tolerance	$\pm 5\%$ & $\pm 10\%$
Rated voltage (dc)	250-630, 1000, 1500, 2000 Volts
Rated temp	85°C
Climatic category	IEC 68 40/085/56

Yes, rush me more information on Philips POLYPROPYLENE CAPACITORS

Name: _____

Designation: _____

Area of Application: _____

Company Address: _____

Philips India

Eicoma Division, Band Box Building,
254 D Di Annie Besant Road Worli, Bombay-400 025

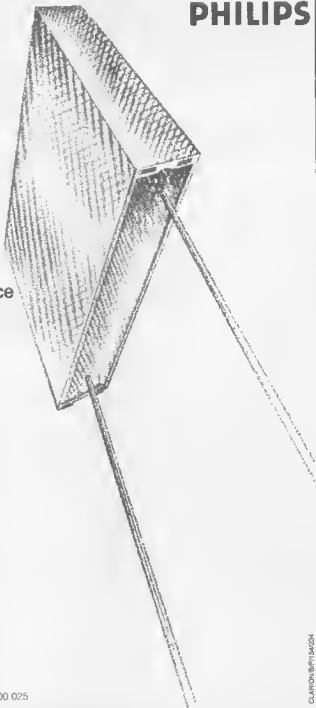

CLARION/8/11/54/224

Philips — the trusted Indian household name for over fifty years



DESIGN YOUR INDUSTRIAL MICROCOMPUTER DATA ACQUISITION AND PROCESS CONTROL SYSTEM USING **IMPACT-1**

Microprocessor Training & Development System With Built-in

ADC DAC

Important Features:

- Eight Channel ADC with 100 micro seconds conversion time. ■ Single Channel DAC with 0 to 12 V analog output ■ 8085A CPU @ 3 MHz. ■ Fully decoded Memory and I/O.
- Battery Back Up for RAM. ■ Powerful Monitor Firmware with ADC/DAC subroutines.
- Fully buffered STD bus for expansion. ■ On board EPROM programmer ■ Built in interfaces for ASCII Keyboard, Printer and Cassette Recorder. ■ Eight channel Interrupt Controller with programmable priorities.

Options:

- 64K Memory Card with Real Time Clock/Calendar ■ VDU Card with Editor/Assembler/Disassembler. ■ FDC Card with CP/M BIOS ■ ROM based FORTH and Tiny BASIC.
- ASCII Keyboard. ■ Video Monitor ■ Floppy Disc Drives ■ 80 Column Dot Matrix Printer.

IMPACT-1 can be converted into a powerful Process Control Computer using the expansion cards and optional peripherals offered by us.

Introduced for the First Time in India by:



**Creative
Data Systems**

14, Hanuman Terrace, Tara Temple Lane,
Lamington Road, Bombay 400 007.

Tel: 362421, 353029

Tlx: 011-71801 DYNA IN, Gram: ELMADEVICE

ADDMark

IMPACT-1 can be customised
for OEM use by:



tetrattech

tetrattech

TETRATTECH INDUSTRIAL SERVICES

Post Box-8860, Vile Parle (East), Bombay 400 057

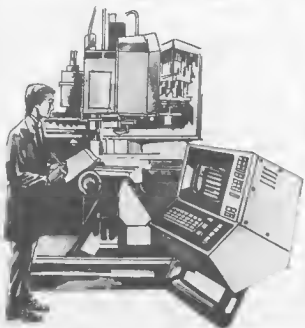
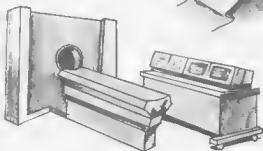
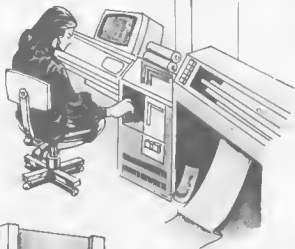

ICM

Servo-Controlled Voltage Stabilizer

Technically superior to any
such product on the market



LAST TANGO
*It pays
to protect
your
Equipment*



Engineering Systems International

British Bank of Middle East 2nd Floor, 16, Veer Nariman Road, Fort,
Bombay-400 023. Tel: 2049543, 2049584 Grams: ESINTAL.

COMPUTER-SCOPE-1

by R v Linden

To help those many people whose workshop includes a computer but not an oscilloscope, this article presents a drive unit that enables the computer to be used as an oscilloscope.



The idea of using a computer as an oscilloscope is based on the fact that it already has a viewing screen and that it can cope with graphics. All that is required, therefore, is a unit that stores the signal to be measured in a memory, after which the computer can read the memory and display the data on the monitor. The article will be in two parts: this month the general layout and the complete circuit will be discussed, while part 2 will deal with the construction and the alignment.

Block diagram

The first section of the unit, i.e., the AC/DC switch, attenuator, and amplifier, consists of analogue circuits, although the first two are controlled by binary signals. An off-set may be added to the amplifier via a digital-to-analogue converter. The incoming signal is then digitized, after which a fast analogue-to-digital converter translates the samples into 7-bit data words that are

stored in a random-access memory via a buffer stage.

The output of the A/D converter is also applied to a trigger and comparator. The latter compares the instantaneous value of the signal with the preset trigger level. If that level is exceeded, either in a positive or in a negative sense, depending on the preset trigger edge (leading or trailing), the data is stored in correct sequence in the RAM with the aid of an address counter. The eighth bit of every byte indicates when triggering

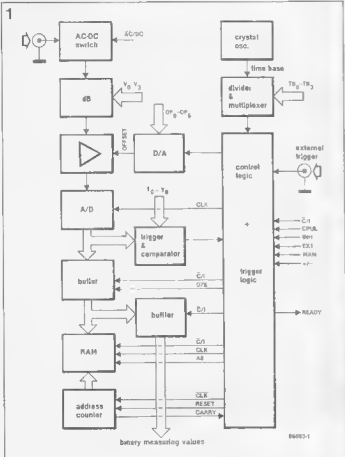

Fig 1 The block schematic of the computerscope drive unit

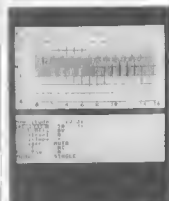
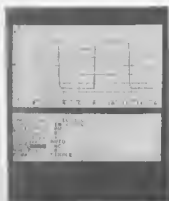
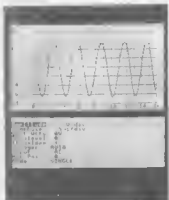
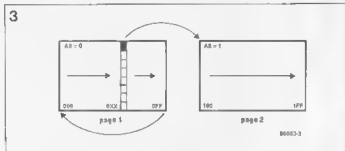

Fig 3 The RAM is divided into two pages the first is used for storing 256 pre-trigger bytes, and the second for storing 256 post-trigger bytes. A specific trigger bit indicates at which instant operation is to be transferred from one to the other



takes place.

The memory consists of two parts, each of 256 bytes. The first part holds 256 pre-trigger measuring points, and the second 256 post-trigger measuring points. A comprehensive address ensures that writing to, and reading from, the memory takes place in the correct sequence. Sixteen different time bases, derived from a crystal oscillator, are provided.

Communication between the drive unit and the computer is effected via two 8-bit I/O buses; this enables most computers to be used.

The computerscope is controlled via software. A menu-type layout gives the user the possibility of setting all measuring parameters with only a few keys.

Circuit diagram

The input is at the centre of Fig 2 and is connected direct to the AC-DC switch, which is formed by capacitor C_1 shunted by DIL relay Re_1 . The switch is followed by the attenuator, which consists of two parts: the first can be arranged to attenuate by a factor 1, 2, or 5, and the second by 1, 10, or 100. The total attenuation is set from the computer by means of multiplexers IC_{23} and IC_{24} . Both IC_{23} and IC_{24} are controlled via lines V_0 and V_1 , while the multiplexers in IC_{24} are switched via lines V_2 and V_3 . In this manner the sensitivity can be set between 10 mV/div and 5 W/div. At the input of the first divider relays instead of multiplexers are used

because of the maximum allowable voltage here. Diodes D_1 to D_5 incl. protect the inputs against too high voltages.

A variety of fixed and variable capacitors in the attenuator sections provide compensation when square-wave signals are processed.

The signal at the output of the second attenuator has a maximum value of 80 mV_{pp}. It is then raised to 2 V_{pp} by amplifiers A_1 , A_2 , and A_3 , to give a signal that can be processed by the A/D converter at the highest possible resolution.

An off-set is added to the signal in A_3 to enable a vertical shift across the monitor screen. The off-set is provided by a D-A converter, which is housed in IC_{11} together with the first A/D converter. The computer sends

Fig. 2. The circuit diagram of the computer drive unit

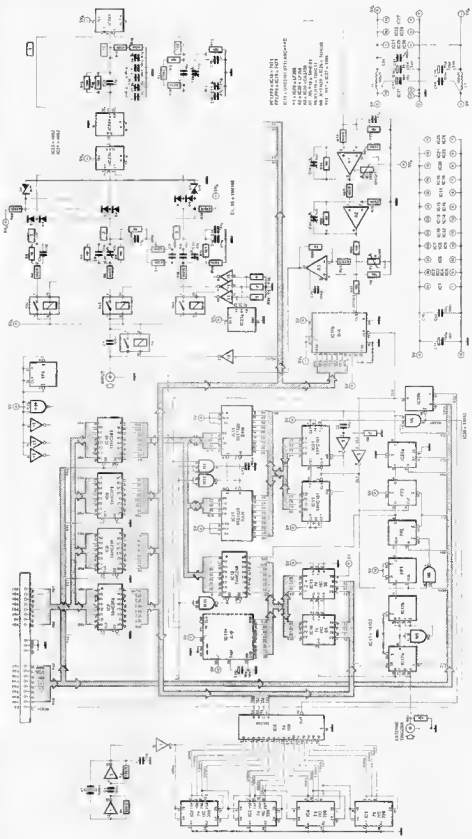

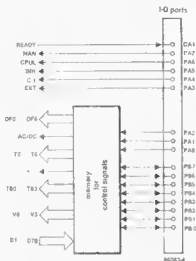

the off-set data to the D-A converter via lines OF₇ to OF₁ incl. The standard value of the off set is 1 V when the sample lies exactly within the range of the A-D converter (bear in mind that the converter cannot process negative values). Only seven of the ten bits available at the D-A converter are used here which, because of the graphics resolution of the computers used, is more than enough.

The output signal of A₇ is then applied to a fast A-D converter, which contains a separate comparator for each digital level, i.e. 256 in all. The conversion time is, therefore, only 26.3 ns (corresponding to a frequency of 38 MHz). The highest clock used is 8 MHz, resulting in 8 samples per period at an input signal of 1 MHz.

Because of the arrangement of the system, only 7 bits are used, which is sufficient for an accurate display. The eighth bit is used for storing the trigger data. The reference voltage for the A-D and D-A converters is generated by the IC itself. The only external component is capacitor C_{5A}. The memory section also needs fast ICs, and in the present circuit Type IM51420 was chosen. This is a RAM with an access time of 45 ns and a capacity of 4 K × 4 bit. Two of these ICs, IC₁₇ and IC₁₈, are connected in parallel to give a width of 8 bits. The data lines of the RAMs are connected with the outputs of the A-D converter via buffer IC₁₂. Of the total memory capacity only 512 bytes are used for data storage; the remainder is available for possible later extensions.

The digitizing and storing of the samples is taken care of by the clock

provided by the time base. Operation of the A-D converter is commenced at the trailing edge of the clock pulse, and at the same time the address counter of the RAMs is increased by 1.

The random-access memory consists of two pages: page 1 contains address 000 to 0FF, and page 2, addresses 100 to 1FF. In the absence of a trigger signal, page 1 is written to. As soon as a trigger arrives, the eighth bit of the relevant byte goes high, when writing is transferred to page 2—see Fig. 3. Once this page is full, writing to the memory stops, and the computer is advised that writing is completed by the READY signal. In this way, there are always 256 pre-trigger and 256 post-trigger sampling points. After the computer has read the memory, the next writing cycle can be started. As long as there is old information on page 1, triggering is prevented for 256 clock pulses by signal INH. This is calculated by the computer from the state of the time base.

The time base (at the left of Fig. 2) consists of crystal oscillator N₁-N₂, which is followed by a number of ÷2 and ÷3 dividers, IC₂ to IC₇ incl. The computer connects one of the outputs of the time base to the CLK line of the system via multiplexer IC₈. Latches IC₉ to IC₁₅ are provided for the exchange of signals between the drive unit and the computer. Circuits IC₁₆ to IC₁₈ serve to store data which are sent by the computer to the drive unit via PB₀ to PB₉ incl. PA₀, PA₁, and PA₂ are used as write signals for the three ICs.

Circuits IC₁₉ and IC₂₀ form an 8-bit comparator for the trigger signal, which is provided (in binary form) by



Fig 4 All connections between the drive unit and computer in a row

the computer. As soon as the level of the input signal exceeds that of the trigger, the level at the >Q output of IC₂₀ (pin 5) changes state. The edge of this pulse also indicates whether the input signal exceeded the trigger in a positive or in a negative sense.

The output signal of the comparator is applied to a dual four-channel multiplexer, IC₂₁. The first part of this stage enables a choice to be made between the >Q output of the comparator and the external trigger input with the aid of the EXT signal. The second section, IC₂₂, is used to choose between the output of the first multiplexer and the inverted output signal, that is, between triggering at the leading or at the trailing edge of the input signal.

The trigger signal is then fed to bistables FF₁ and FF₂, where it is combined with the CLK and INH signals. Bistable FF₁ also provides the eighth data bit for the RAMs: as soon as the circuit is triggered, its output goes high. The eighth data bit is also clocked in bistable FF₂, after which it is used as ninth address bit for the memory via multiplexer IC₂₃. During reading, the circuit is switched via IC₂₀ to the INH signal as ninth address line, whereas during writing, the output of FF₁ is used for this purpose.

When the ninth address bit becomes logic 1, the address counter is reset via network R₂-C₅.

Control signals

The connections between the drive

unit and the computer are shown in Fig. 4. A total of 17 port lines are used: PA₆ to PA₇, PB₆ to PB₇, and CA₁.

Signal MAN enables manual triggering via the keyboard. Bistable FF₂ is then set via N₆, which gate ensures that the MAN signal and the CLK signal in the drive unit are synchronized.

CPUL is the clock provided by the computer for reading the RAMs (is applied to IC₂₀₂).

The INH signal prevents triggering of the circuit via bistable FF₂ until the RAM has been read completely by the computer.

The computer uses the \bar{C}/I signal to determine whether the RAM is being written to by the drive unit, or is being read by the computer (logic 0 = reading).

A logic 1 on the EXT line actuates the external trigger input.

Lines OF₂ to OF₄ carry the off-set voltage that is added to the input signal via the D-A converter. The standard value should be 1000000 or 0FFFFFF to give an off-set voltage of 1 V (OF₂ = MSB).

A logic 1 on the AC-DC line causes relay Re₁ to be energized, so that capacitor C₁ is short-circuited and DC components in the input signal are passed on.

The data on the T₆ to T₈ lines determines the trigger level. To enable triggering at the zero crossing of a signal, the value should be set to exactly half the signal level, that is, 1000000 because of the standard off-set of 1 V (T₆ = MSB).

The +/- line enables the computer to choose between triggering at a signal that exceeds the trigger level either in a positive or in a negative sense.

The READY signal indicates to the computer that writing into the RAM has been completed and that the reading process can begin. The internal clock signal is switched off at that instant.

Lines TB₂ to TB₃ servo to choose the required time base via IC₅. A value of 0000 corresponds to 1 mV/div, and 1111 corresponds to 100 mV/div (TB₂ = MSB).

Lines V₆ to V₇ are used for setting the input sensitivity via the

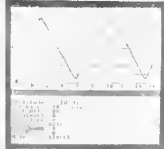

multiplexers in the attenuator stages. A value of 0000 gives a sensitivity of 10 mV/div, while 1010 gives a sensitivity of 5 V/div.

Data lines D₁ to D₇ incl. are used for transporting the binary values from the drive unit to the computer (D₇ = MSB). Line D₇ carries the trigger bit.

This information makes it possible to write a suitable program for the computerscope. In many cases that will not be necessary, however, because a complete program listing for the BBC, the Electron, the Commodore C64, and, very likely, MSX computers will be supplied with the printed-circuit board. More about this in Part 2 next month.

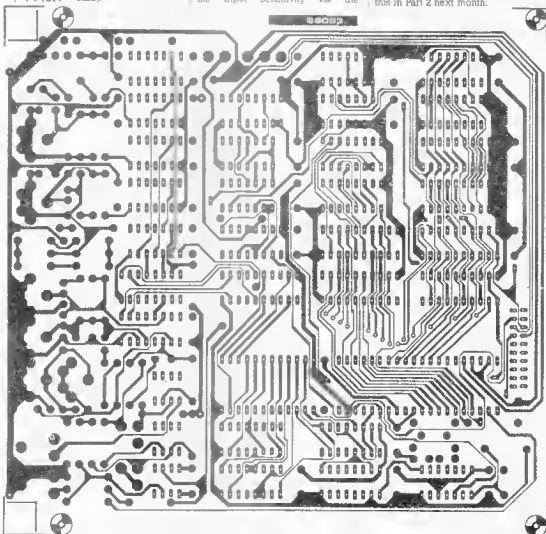

AIR DEFENCE SYSTEMS FOR COUNTRIES AND CONTINENTS

by John Nicholls, CEng, MIERE*

Air provides the breath of human life, and the space it occupies around the globe has become the dominant "play volume" in man's defence of his kingdom. The armed forces meet varying threats. The primary concern of navies is high and low flying attack weapons, armies have to contend with strike aircraft and missiles, while air forces are required to intercept bombers and fighters and eliminate all threats that exist in the air space. To maintain vigilance in times of peace and to meet the threats of insurgents in times of war it is vital that all the resources of the armed forces are co-ordinated. Co-ordination is important not only for the air battle but for the safe operation of civil aircraft, and requires close co-operation between the defence organizations and civil aviation authorities. An air defence system provides this co-ordination. It is able to detect, recognize, and monitor information on objects in the air space. It can provide the command and control of interceptor aircraft, the dissemination of target information to field batteries of guns and missiles, and it can provide the command with a display of a recognized air picture and sometimes of the surface as well. This includes all information necessary for decisions to be made

Modular advantages

Traditionally, only highly industrialized countries have been able to benefit from large scale air defence systems. Each system would be custom designed resulting in ex-



Air
defence
systems

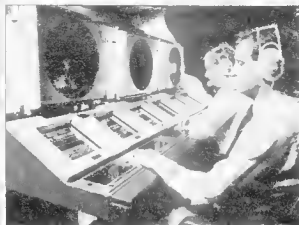

pensive and specialized solutions. Analysis has shown that common functions exist in all the elements of air defence systems around the world and it is this that, for instance, Plessey Radar has capitalized on with its air space management products. The result is a base of hardware and software models, which include off- and on-line maintenance aids able to be configured at low cost into virtually any size or variety of air defence system by the addition of customer specific facilities.

The modular design approach has additional advantages. Rigorous specifications and methodologies can be applied and the modules subjected to thorough in-service use. It also makes the transfer of technology more amenable and simplifies local maintenance. Plessey Radar already has a number of such systems installed and an operational development and demonstration air defence facility at its systems headquarters. It is now feasible for any nation to have an air defence system that

precisely meets its needs and is affordable — both initially and throughout the life of the system. The next few years should see a large number being installed and integrated on an international scale.

The air picture

The first requirement of an air defence system is to detect the targets. This can be done passively with electronic sensor measurement (ESM) equipment to detect audio, radio frequency, and infrared emission. It can also be done with active sensors such as radar and laser equipment and, of course, that original sensor, the eye, to report visual sightings. All the information from these sensors, whether they be static or mobile, on the land, at sea, or in the air, is processed by reporting posts. The data provided by reporting posts range from crude directional bearings to accurate recognition of the targets along with positional coordinates.

From the reporting posts, the data are transmitted for processing at a control report post. Here, the data are combined with known information, such as civil aircraft flight plans and information from secondary surveillance radar, to provide a track database whose accuracy and completeness determines the quality of the air defence system. Operators at display consoles in the control reporting post use this track information to select their targets, to control fighter aircraft on their interception missions using air-ground-air radios, or to provide targeting information to SAM (surface-to-

air missiles) and gun weapon sites. The information is also fed to an air operations centre where again it is combined with inputs from other control reporting posts, processed with multi-sensor algorithms, and displayed as a recognized air picture for the whole play area covered by the sensors with each target having a unique track identity.

Defensive network

At the air operations centre, other information is also shown on consoles and large screen displays to enable the command to plan the tactical and strategic air battle. Details of the status and availability of aircraft, guns, and missiles are available along with mission designations and the logistic situation from national and allied forces. The remaining task of the air defence system is to pass the recognized air picture to a central joint operations centre. Here, a totally integrated view can be obtained by combining the information from the air operations centre or centres with similar inputs from navy and army systems to give a complete recognized air and surface picture of the country's defensive network.

The command and control aspects of an air defence system will vary, depending on factors such as the size of the country, the volume of air space to be defended, and the existing defence management organization. There are three fundamental methods of meeting the requirements.

First, command and control can be centralized. Activities undertaken by the control reporting post and the air operations centre will normally be centralized into one facility, often in a single building for small

countries with, say, six sensors giving coverage of up to 930 x 930 kilometres, this is a suitable air defence system architecture.

Control options

Command and control structures can be kept relatively simple and the number of expert staff required can be limited. The track database — targets that can be effectively monitored — would typically contain up to 300 tracks and controllers could handle up to ten "close" and 20 "loose" interceptions.

Second, where air space management demands a significant number of sensors (more than six) and the defence assets such as guns and aircraft are distributed over large areas, a system with centralized command but decentralized control can be used.

Groups of two or three reporting posts pass data to tactical command reporting posts which are normally termed sector operations centres when more than one sensor is connected. These in turn transmit their information to the air operations centre. This is the most common form of air defence system. The dispersed sensors and mobile command reporting posts concept is resilient to damage and the command organization is relatively easy to implement. Typically, each sector operations centre — the decentralized control — can handle 200 tracks and 30 control interceptors while the air operations centre — the centralized command — would have a track capacity of over 500 after combining all the inputs from the sectors. The third method is to distribute command and control responsibility to centres that exercise total authority in specified areas. Each then reports to a centralized strategic

command function. This air defence architecture meets the needs when several states are involved or when a large continental area has to be defended. It is an extremely complex task to define the hierarchy of command, to identify and allow for overlaps of data, and to distribute this information around the regions. It requires close co-operation between participating states.

International integration

As well as accommodating the many variants of command and control, an air defence system design must allow for future expansion, not only within the country but also for integration with international air defence facilities.

The data processing system is the key to this versatility. A well-designed system will have modules of hardware and software that can be integrated in various forms depending on the requirements. It must at the same time be tolerant to failure and able to accommodate different computer types and software languages that are likely to be introduced as the system expands and equipment becomes obsolescent.

The ideal architecture consists of distributed nodes of processing that are expandable in power. These are coupled via local area network (LAN) open system interconnection (OSI) standard data communications. Computers with applications software can be added to the local area network with no major impact on the logic system. Availability can also be ensured by building in spare computers coupled with automatic fault detection and techniques that ensure graceful degradation.

The hardware must be capable of installation in

mobile cabins that can be transported by land, sea, or air, as well as in static facilities. Software, likewise, must be capable of being maintained and amended on site to handle local environmental data.

Compatible techniques

Most countries have many sensors, rarely from the same supplier. The other command and control systems with which the air defence network must interface are also likely to be different. It is, therefore, unlikely that the data to be exchanged are of similar format.

The air defence system must use techniques that ensure compatibility at all levels from the reporting post up to the air operations centre while minimizing any impact on the central air defence data handling systems and the other systems with which it is interfaced. The distributed logic system architecture can readily accommodate the special normalizing processors needed to overcome these problems and they can be interfaced to the local area network by the appropriate open system interconnection communications (LPS)

* John Nicholls is an Engineering Executive with Plessey Radar Systems ● Oakcroft Road ● Chessington ● Surrey KT9 1QZ

Voltage comparison on a 'scope

There is frequently a need, when experimenting with circuits, to measure or compare several DC voltages at test points etc. Since most readers are unlikely to possess more than one multimeter this can be rather tedious. Using this simple circuit, up to four voltages can be compared or measured on any oscilloscope that has a DC input and an external trigger socket. The circuit uses only three ICs, five resistors and a capacitor.

The complete circuit of the voltage comparator is given in figure 1. The four voltages to be measured are fed to the four inputs of a quad analogue switch IC, the outputs of which are linked and fed to the Y input of the 'scope N1 to N3 and associated components form an astable multivibrator, which clocks counter IC3. This is a decade counter connected as a 0 to 3 counter by feedback from output 4 to the reset input. Outputs 0 to 3 of the counter go high in turn, thus 'closing' each of the analogue switches in turn and feeding the input voltages to the 'scope in sequence.

Output 0 of the counter feeds a trigger pulse to the 'scope once every four clock pulses, so that for every cycle of the counter the 'scope trace makes one sweep of the screen. A positive-going

This simple circuit allows up to four DC voltages to be measured or compared by displaying them side by side on an oscilloscope.

(H. Spenn)

trigger pulse is available via R4, or a negative-going trigger pulse is available from the output of N4 via R5. The resulting display is shown in figure 2, four different input voltages being fed to the inputs in this case. The oscilloscope timebase speed should be adjusted so that the display of the four voltage levels just occupies the whole screen width.

The supply voltage $+U_b$ may be from 3 to 15 V, but it must be noted that the input voltage should be positive with respect to the 0 V rail and not greater than $+U_b$. If voltages greater than this are to be measured then potential dividers must be used on the four inputs.

Setting up

To calibrate the circuit, simply feed a known voltage into one input and adjust the Y sensitivity of the 'scope to give a convenient deflection (for example one graticule division per volt input). The unknown voltages may then be fed in and compared against each other and against the calibration.

The circuit can easily be extended to eight inputs by adding an extra 4066 IC and connecting IC3 as a 0 to 7 counter (reset connected to output 8, pin 9).

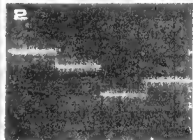
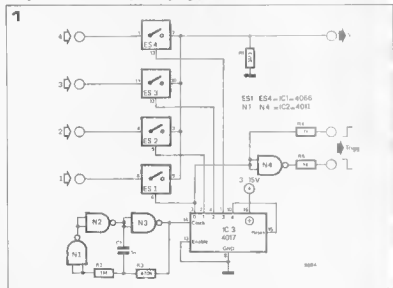
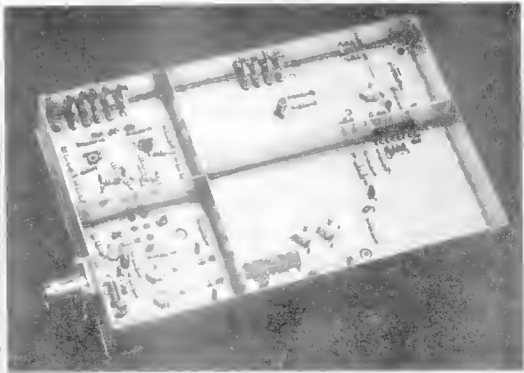

Figure 1. The circuit diagram of the voltage comparator.

Figure 2. An example of 4 random voltage levels displayed simultaneously on the 'scope.

INDOOR UNIT FOR SATELLITE TV RECEPTION-1

by J &
R v Terborgh



Following last month's general introduction to satellite TV reception, this article describes the construction and operation of the indoor unit (IDU). This is in essence an interface between the low-noise converter (LNB) at the dish aerial and a conventional television receiver. The first part of the article deals with the RF board contained in the IDU.

Indoor converter for satellite TV

- Single conversion wideband FM tuner
- Complies with standard LNB IF range 1950 - 1750 MHz and download feed systems for CS and future DS satellites
- Includes VHF vision & sound modulator, NB theft alarm, polarization selector, audio and video outputs, and switchable AFC
- Modulator test and satellite scan circuits simplify initial setting up and dish positioning
- Also usable as a 23 cm band 1240 - 1280 MHz amateur television (ATV) receiver

To be detailed in a forthcoming article

Before embarking on this project, make absolutely certain that a 1.2 m and 1.8 m dish aerial can be securely installed to give an unobstructed line-of-sight path to the relevant satellite(s). As stated last month, it appears that garden installations are all right, but roof installations require planning permission. Careful planning and expert counsel in this matter will prevent costly and frustrating disappointment at a later stage. It should be noted that at present it is

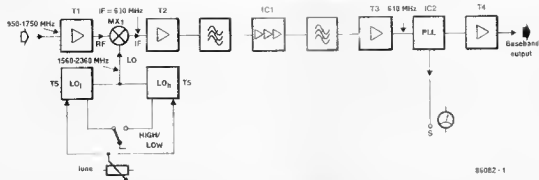

85082-1

virtually impossible for most home constructors to build either the dish aerial or the low-noise converter, and these will, therefore, have to be bought or rented. In this context, see *Satellite TV reception* (p.40) and *Harrison Electronics'* advertisement (p.86) in the September 1986 issue of *Elektron Electronics*. Fortunately, prices of these units have already started to come down due to the rapidly growing interest in satellite TV reception.

Although the construction of the indoor unit is not recommended to absolute beginners in electronics, it should be noted that a number of prototypes were built by constructors with only limited experience. In the main, the results were fully satisfactory, although all agreed that their task had taxed them to the full, requiring not only great precision and care in soldering, but above all close attention to the constructional details. The present article, therefore, aims at giving the maximum clarity to all matters concerning very-high-frequency techniques.

For an explanation of parameters and abbreviations used in this article see *Satellite TV reception* in the September issue of *Elektron Electronics*.

Block diagram

The block diagram in Fig. 1 shows that the indoor unit is a single-conversion superheterodyne tuner. A low-noise amplifier raises the level of the 950-1750 MHz input from the LNB, which is then mixed with the 1560-2360 MHz output of local oscillators T₁ and T₁'.

It should be noted that LNBs used for the reception of communication satellite TV programmes use a 10 GHz local oscillator to give an output of 10.95-11.75 GHz. Fortunately, the European Broadcasting Union (EBU) has recommended (literature reference [1]) that LNBs for direct broadcasting satellite (DBS) services also

have an output of 950-1750 MHz.

IF amplifiers T₂, IC₁, and T₃ intercoupled by band-pass filters, provide a gain of about 42 dB at the half-power bandwidth (>36 MHz). A phase-locked loop (PLL) demodulates the 610 MHz IF signal as passes the baseband (about 0.8-8.5 MHz) to the video processing circuits (described in next month's issue) via buffer T₄.

The relatively high IF of 610 MHz ensures good rejection of the 2170-2970 MHz image frequencies, f_i ($f_i = f_{LO} + f_{IF}$).

Circuit description

In the circuit diagram of Fig. 2, the SHF input stage, T₁, a Type BFG65 transistor, has been designed for low-noise ($F_{as} \approx 4.5$ dB max) wide-band operation. It presents a 50-ohm impedance to both the input from the LNB and to mixer MX₁. Its gain ranges from about 12 dB at 950 MHz to around 8 dB at 1750 MHz.

MX₁ is a Type HPFS11 monolithic, wideband, double-balanced mixer (DBM) consisting of four Schottky diodes, which have a low junction capacitance and provide linear operation over a wide range of LO and RF power levels. These diodes are fed via high-quality transformers to give a meticulously balanced set-up suitable for operation at high RF, LO, and IF frequencies. The internal organization of the device is shown in Fig. 3a.

The Type HPFS11 was chosen because of its robustness, excellent performance-to-price ratio, and stable impedance at all three ports, which are designed to handle a wide range of RF input signal levels. Its drawbacks are its cost as compared with a discretely built mixer, and its conversion loss. However, an active mixer, which would have some conversion gain, is difficult to keep stable over the RF input range of 950-1750 MHz. Moreover, the passive DBM typically causes the carrier-to-

noise ratio to be less impaired in the mixing process.

The characteristic curves in Fig. 4 show some of the parameters of the HPFS11. In particular, Fig. 4c shows the excellent performance of the device at a local oscillator power level of +7 dBm (about 5 mW). Since the input impedance, Z_i , at pin 8 is 50 ohms, the output voltage, U_{LO} , of the local oscillator is given by $U_{LO} = \sqrt{P_{LO} Z_i} = 0.005 \times 50 = 0.5$ V rms.

Readers interested in balanced RF mixers should find the *RF/IF Signal Processing Handbook, Volume 1* (literature reference [2]) well worth reading.

Local oscillators T₁ and T₁' cover the 1560-2360 MHz band at sufficient power for satisfactory operation of the mixer, and have the stability required for wideband FM TV reception. Since it proved virtually impossible to achieve this performance with a single transistor, two varactor-tuned Type BFW92 transistors are used. The two sections of the oscillator, LO₁ and LO₂, are tuned to the highest and lowest channels of satellite TV services respectively by C₁ and C₁'. Section LO₁ covers a range of about 1600-2000 MHz, and LO₂ operates over roughly 1800-2400 MHz. The stability of the oscillators is so good that automatic frequency control (AFC) is not, strictly speaking, required.

The relevant oscillator section is selected with S₁. Resistors R₁₀ and R₇, in LO₁, and R₁₁' and R₇' in LO₂ are damping resistors, which provide enough inductance to ensure correct matching to the 50-ohm LO input of mixer MX₁.

The common 3-32 V tuning voltage, V_{TUNE} , is applied to varactors D₁-D₄ (LO₁) and D₁'-D₄' (LO₂) via resistors R₁₅ and R₁₅' respectively.

The oscillator stages operate in the common collector mode: oscillation is achieved through positive feedback via the base-emitter capacitance of the transistors.

Fig. 1 Block schematic diagram of the RF board in the IDU. Note that two local oscillators LO₁ and LO₂ have been incorporated to supply the 1560-2360 MHz injection signal.

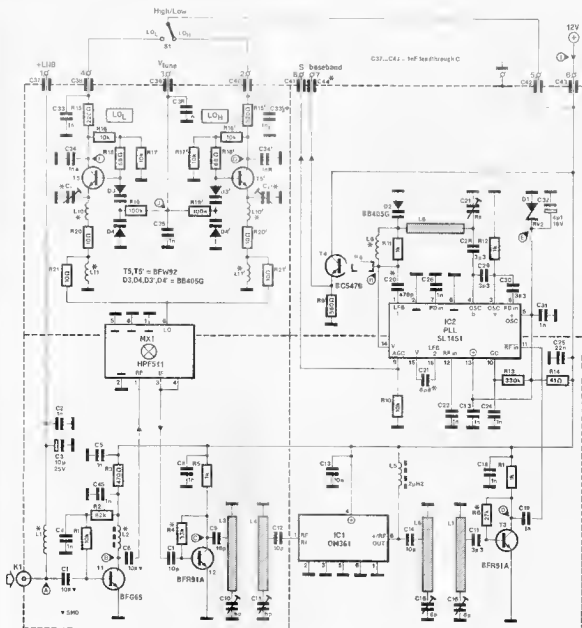

▲ traapezoidal C

■ 100 nF

68882-2

- A: 1.5V voltage 15 mA 20 V in - 100 mA
 B: +6.5 V
 C: +5.5 V
 D: +5 V
 E: +8.2 V
 F: +8.0 V (D.C. voltage)
 G: 8.0 V (D.C. voltage)
 H: 2 V / 4.5 V (intervals on V₁, C1 on 1)
 I: 100 mA
 J: +3 V / 32 V / 0
 All values typical and within 10%. Voltages measured with respect to ground with a DMM
 10: 1 MHz

pin 1 identification

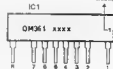

The 610 MHz IF signal is taken from pin 3 of MX, and capacitively fed to a conventional amplifier, T₁, which provides about 10 dB gain at a relatively low noise figure; it also ensures correct termination of the IF output of MX.

The first IF band-pass filter consists of two critically to slightly over-critically coupled tuned line inductors, L₁ and L₂. Correctly aligned these have a 3 dB pass band of about 40 MHz, a relatively low insertion loss, and cause minimal stray radiation. Both the collector of T₁ and the input of IC₁ are capacitively coupled to a low-impedance matching tap on the relevant inductor.

Second IF amplifier IC₁ is a wide-band hybrid IC type OM361, which is primarily designed for VHF/UHF masthead aerial amplifiers and MATV systems. This single-in-line (SIL) device contains a 3-stage RF amplifier as shown in Fig. 3b. The OM361 was chosen for its high gain (about 26 dB at 600 MHz) and ease of input/output matching. Power to the final two cascaded transistors is supplied via choke L₃ to prevent the RF signal from being short-circuited by the thoroughly decoupled positive supply rail.

Band-pass filter L₄-L₇ and amplifier T₂ have functions and characteristics similar to those of L₁-L₂ and T₁ respectively. The IF signal at the collector of T₂ is capacitively fed to phase-locked loop (PLL) decoder IC₂.

It must be stressed that the overall performance of the IDU depends to a large extent on the bandwidth, rather than the gain, of the IF chain. Since the deviation of the satellite TV signal is typically ± 13.6 MHz_{pp}, and the baseband occupies some 8 MHz, the IF bandwidth must be not less than 35 MHz for satisfactory performance.

It is, therefore, clear that the IF band-pass filters are crucial to the correct operation of the IDU. Since the combined gain of the IF amplifiers amounts to 48 dB, and that of the IF chain is about 42 dB, it follows that the total insertion loss of the filters is around 6 dB.

Next month's article will contain measurement data relevant to the RF sections of the IDU.

PLL decoder IC₂ is a purpose-designed satellite TV FM demodulator Type SL1451 from Plessey and is part of an extensive range of passive and active components intended for satellite reception systems (literature reference [3]).

The functional diagram of the device is shown in Fig. 3c, inset is the on-chip voltage-controlled (Clapp) oscillator (VCO)

The Clapp oscillator generates the 610 MHz sub-carrier for demodulating the IF signal. It is tuned externally by line inductor L₈, varactor D₁, and trimmer C₂₇, and coupled to one of the (differential) inputs (pin 6) of the phase detector via C₂₈. The other input of the detector, pin 7, is decoupled by C₂₉. The output power of the oscillator is stated to be -10 dBm, which is claimed to be the optimum figure for threshold performance (literature reference [4]).

Varactor D₁ provides a frequency-to-voltage gradient of about 14 MHz per volt at the most commonly used deviation of 13.5 MHz_{pp}, therefore, the baseband output swing is about 1 V_{pp} (note, however, that some transponders are run at higher deviation values).

The RF amplifier in the PLL chip is a differential type with one input (pin 12) decoupled, which results in an input handling range of -25 dBm to 0 dBm.

Both video and inverted video are output: the former is fed to D₂ via primary feedback loop L₉-R₁₁, which

also serves as an RF block reactance. Both outputs, pins 15 and 14 respectively, are fed back to the relevant input pins 16 and 1 respectively by means of capacitors, which define the secondary loop filter response, the values of C₂₀ and C₂₁ may be altered to suit the deviation of the received signal; this will be reverted to in a forthcoming continuation of this article. The stated values of these components ensure a PLL noise threshold of about 10 dB C/N at deviations of 13.5 MHz_{pp} to 20 MHz_{pp}. Careful redimensioning of the secondary loop arrangement may lower the PLL threshold to 8.5 dB C/N, this is not at all easy, however, and the matter will be taken up for examination in due course. Around the threshold level, the PLL produces sparkles or spikes on the picture screen. This effect, however, disappears as soon as the C/N figure rises some 2.5 dB above the PLL threshold.

The automatic gain control (AGC) output of the SL1451 is used to drive a relative signal-strength (S-) meter

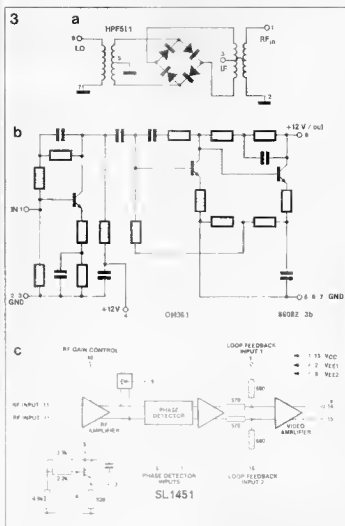
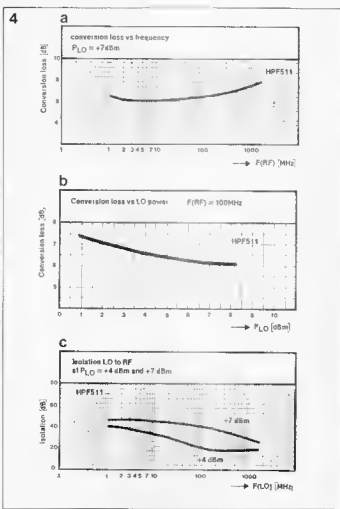

Fig. 3. The microcircuit configurations of the central building blocks of the IDU RF board (a) wideband double balanced mixer HPP511, (b) hybrid VHF/UHF amplifier chip Type OM361 and (c) FM-TV PLL detector Type SL1451, featuring an on-chip 400-800 MHz Clapp oscillator

Fig 4 Graphs correlating a number of important technical characteristics of double-balanced mixer MX1. Remember that RF 950 1750 MHz IF 610 MHz and LO 1500 2400 MHz at +5 to +7 dBm, which is obviously the correct level for lowest conversion loss and highest port-to-port isolation

Fig 5 Before fitting any parts onto the board it is necessary to finish all drilling and fitting of the metal enclosure sized 100x160x30 mm (WxLxH) incl. of top and bottom lids. Fig 5d shows the home-made version of feed through C44



5

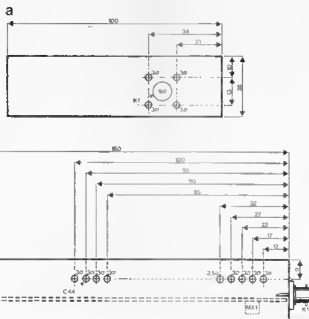

circuit via pin 9. Buffer T4 is a simple emitter follower that serves to output the baseband at low impedance. Note that its output is direct coupled, since the DC component is required for use in the AFC and video processing circuits. It is important that feedthrough capacitor C44 has a capacitance of not more than about 30 pF to prevent it filtering or limiting the baseband. The supply voltage to the PLL chip is stabilized at 8.2 V by zener diode D1, and is also decoupled at several points to prevent oscillator instability and signal loss.

The dashed lines in Fig. 2 denote metal screens on the printed-circuit board these provide effective protection against stray inductive coupling of tuned circuits and parasitic oscillations. Finally, all DC connections to the RF board are decoupled by 1 nF feed-through capacitors

Construction

Contrary to the normal order in which electronic projects are put together, it is necessary to finish all mechanical work as detailed below, before fitting any parts onto ready-made PCB Type 86082.1.

First, prepare a 160x100x28 mm (inside) brass or tin sheet enclosure as shown in Fig. 5. If you can not obtain a preformed enclosure, you will need to cut four suitably sized pieces of 1...2 mm thick brass, drill two of these as shown in Fig. 5a and 5b, and join them to form a neat box using Sellotape at the corners to maintain right angles as you solder, using a heavy-duty ($\geq 100 \text{ W}$) iron. Brazing is, naturally, even better.

Check whether the eight feed-through capacitors and BNC flange socket K1 fit snugly into the holes; if not, carefully ream the holes until they do. Do not solder anything as yet.

File a notch into the PCB to allow for the PTFE ring round the centre pin of K1. Check whether the PCB needs any filing off the sides before it can be received into the box. Fit K1 by its four small screws, but do not secure these as yet.

Pre-tin the holes provided for the feedthroughs, and insert these from the outer side of the enclosure. Point them downward as you apply heat and solder, if all goes well, the capacitors should slide snugly into place while hot solder runs smoothly round the conical metal bodies. While soldering, carefully manoeuvre the capacitor into its final position.

Since low capacitance (0.1...27 pF) feedthrough capacitors are difficult

to obtain items, it may be necessary to make a DIY version from a number of parts intended for the isolating of power semiconductor on heatsinks. Fig 5d shows how a small washer, bush, two soldering tags and a bolt plus nut can be put together to act as a low-capacitance feedthrough. It is definitely less elegant than a real capacitor, but it works satisfactorily and has capacitance of about 50 pF. The PCB for this part of the project is a pre-tinned, double-sided type, equipped with 5 mm holes for T₁ to T₃ incl. and slots for C₂ and C₃. Through-plating is effected by soldering component leads at both PCB sides, where required.

Start off by applying some solder onto all ground holes on the PCB, as well as onto its edges at both sides, thus will facilitate soldering at a later stage, and prevents overheating of grounded components when these are fitted. Make sure, however, that holes remain open (use solder wick)

Resistors with a few exceptions in the LO sections of the circuit, these should have their leads neatly bent equidistant from the body with snipe-nose pliers. Pre-tin any resistor lead that is to be inserted into a ground hole. All resistors should be ½ or ¼ watt (except R₄, which is ½ W) carbon film types; not metal film. Resistors should be fitted to rest securely on the PCB component side.

Capacitors: In the case of a supply decoupling capacitor (1 nF, 10 nF, 22 nF, 47 µ and 10 µ), pre-tin the ground lead close to the capacitor body. With some types of 2.5 mm type ceramic capacitors, it may be necessary to carefully remove some of the brittle material on the wire where it leaves the capacitor body, pre-tin as fast as possible, holding the far end of the lead in pliers.

When soldering the ground terminal at the PCB component side, solder can be observed to creep right up to the ceramic body, and spread smoothly over the ground plane. Coupling capacitors do not require this method of pre-tinning, although they should be mounted with the shortest possible lead length as well.

Trimmers are to be pushed securely into the relevant holes and soldered rapidly to prevent deforming of the foil material.

Transistors: with the exception of the BFW92s and the BC547B, b and c leads should be cut off to about 2 mm, e leads to 3-4 mm. Before fitting, note the terminal assignment of the BFG65 to get its position correct. Transistors T₁ and T₂ should be mounted at the EPS side of the PCB, straight onto the relevant tracks and with the type lettering visible from

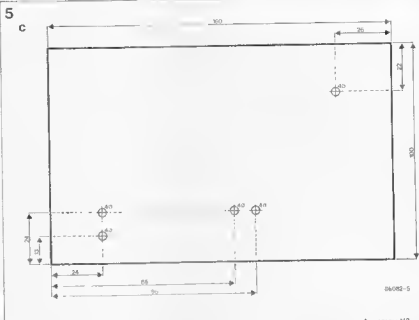

the component side. The e leads should be soldered flush with the EPS side ground plane.

Inductors should present few problems, as their construction data and practical outlook are given in Table 1 and Fig 7 respectively. Note that only two types of wire are required to make all inductors, except L₅ which is a commercial choke. The silver-plated tuned lines should be accurately bent and, with the exception of the longer L₄, pre-tinned at one end.

With reference to the component overlay and track pattern shown in Fig. 6, and observing the foregoing directions, the fitting of parts onto the PCB may now commence.

RF amplifier T₁ and mixer (see also Fig. 9)

Fit all passive parts as set out above. Pay special attention to LNB block inductor L₁, which is fitted slightly off the board surface, and has one end soldered direct onto the RF input

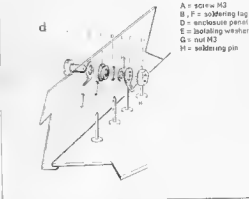

plane. Fit T₁ in its pre-drilled hole, soldering the b and c leads direct onto the relevant tracks, the e leads firmly to ground. Solder SMD capacitors C₁ and C₂ with a light duty (15 W) iron to prevent damaging these devices. Alternatively, C₁ and C₂ may be 6p8 ceramic types mounted onto the relevant planes with the absolute minimum of lead length (±0.5 mm). L₄ and R₁ must be

Table 1

Inductor	turns	SWG wire	internal diameter	remarks
L ₁	12	24 enam.	3 mm	closewound.
L ₂	1	24 enam.		through 3 mm ferrite bead
L ₃ ; L ₄		20 silv.		tuned line; length and location of tap governed by relevant PCB holes, fit 3 mm above ground.
L ₅ ; L ₇		20 silv.		as above but no tap
L ₉	5	24 enam.	R ₁₁	closewound on R ₁₁ .
L ₁₀ ; L ₁₆	1½	resistor lead	3 mm	spacing 1½ mm initially, see Fig. 8c
L ₁₇ ; L _{17'}		resistor lead		tuned line, see Fig. 8c

should have a green and a white ring, the latter indicating the cathode connection

Local oscillators (see also Figs. 8c and 9)

You are now well on the way towards completing the RF board, but the toughest part is yet to come. No PCB holes in many cases, and a few parts mounted three-dimensionally; and yet, it is not as difficult as it may seem at first.

Note that all part references in the following description also apply to the corresponding accented (') parts, unless a specific description is thought necessary to make a distinction

Fit decoupling and bias parts R_{15} , R_{16} , R_{17} , C_{24} , C_{25} and C_{26} as set out above. Pay due attention to the fitting of T_3 , as it has neither a hole nor any tracks to connect to other components. As illustrated in Fig 8a, the transistor's collector lead is to be sharply bent where it leaves the enclosure Push-fit the lead into the slot, along with chip capacitor C_{24} until the latter's shoulders rest firmly on the PCB surface Gently manoeuvre the decoupling capacitor and tap the transistor until this is felt to lie level onto the PCB surface. Note that emitter leads of T_3 and T_3'

should face one another, requiring T_3 unlike T_3' to lie with its type indication facing the PCB ground plane. Carefully solder the track and double ground connections of the chip capacitor, and make sure that solder creeps up along the metallized area and the collector lead, whose excess length is then cut off Shorten the transistor's e and b leads to 2 mm and pre-tin them. Fit stopper resistor R_{16} with the shortest possible lead length (≤ 1 mm) as close as possible to the transistor body (b); this may require the other lead (to

junction $R_{16}-R_{17}$) to be rather longer than usual, but this is of no consequence Sharply bend the anode lead of varactor D_4 , pre-tin, and solder to ground (2x) using the hole provided. Note that the ground connection of D_4' (LOs) is closer to T_3' than that of D_4 to T_3 (LOs). Shorten the D_4 cathode lead to 2 mm, pre-tin, and do the same with D_4' . Carefully join these parts and run the appropriate length of the D_3 anode wire to junction $R_{17}-T_3$ Since junction $R_{17}-D_3$ should exhibit the absolute minimum of stray capacitance



Fig 7

...to
L15
...
least R10
R10
...
Ree
...
body 6 mm of
7.5 mm as
shown
...
Not the differ
ence in posit
ion of L15
L15
...
seen in the
section
...
resistor, but
might make
type
of ceramic
capacitor
used
throughout
the
circuit
use
miniature 2.5 mm
lead spacing
types only

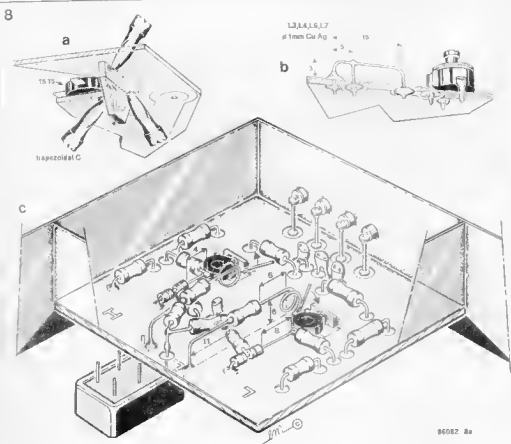
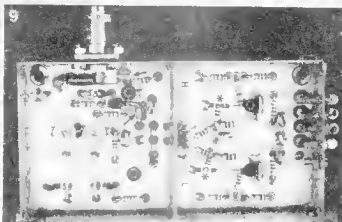

Fig 8 Artist's impression of suggested component mounting methods Fig 8a shows how the T_3 and T_3' collector leads, along with chip capacitors C_{24} and C_{25} are push fitted into 6×1 mm slots in the PCB Fig 8b shows that very little can go wrong if the tuned line inductors are neatly bent to suit the relevant PCB holes Fig 8c, finally should be used as a guide in constructing the 'three dimensional local oscillators' Stick to these guidelines and your IDU RF board will work!



and inductance. R_{10} needs to be prepared as follows. At one side of the resistor body, the protective lacquer should be scratched off where the wire leaves the body. This is conveniently done by holding the relevant area in pliers and twisting the resistor until the brittle stuff comes off. Shorten the lead to 0.5 mm, pre tin, and join it to junction D_3-D_4 with a minimum of solder.

Note that the other lead of R_{10} (and of R_{11}) must be left much longer, so that it can reach junction $R_{10}-R_{11}-C_{23}$. Since these resistors act as current limiters and chokes to the SHF signal on the varactors, this length is of little importance.

Inductors L_{10} and L_{11} are made from the terminal leads of R_{10} . One lead is wound as $1\frac{1}{2}$ turns on a 3 mm former, which may be nail, screwdriver shaft, or even a ball-point refill, as long as it has a diameter of 3 mm. Leaving the turns to revolve around the former, the resistor is gently pulled back until the lead length between resistor body and start of winding matches that given in Figs. 7 and 8c. Space the turns as shown.

The other resistor lead is to act as L_{11} . Observe its length, and edge the remainder of the wire two times as shown in the illustrations. Put the prepared resistor & inductors aside for the moment, and proceed with the most exotic, yet simplest, part of the board, C_{14} , which is simply some 10 mm of left-over component wire 2 mm of which is slightly bent, soldered to the T_3 e lead, and pointed towards C_{18} . The wire should not touch ground, of course. Solder L_{10} to junction $C_2-T_3(e)$; this requires some skill to prevent short-circuiting the inductor turns by either C_{14} or the T_3 emitter lead. Check for any short-circuits caused by excess solder, and carefully bend C_{14} to point to the body of C_{18} . The oscillators will not operate correctly if C_{14} is left out.

Run $R_{10}-L_{11}$ exactly parallel to D_3-D_4

and solder L_{11} to ground, straight onto the PCB surface. Note that no ground hole has been provided; use the relevant illustrations and the component overlay to find the correct location, level with MX_1 pins 7 and 8. R_{10} should now be positioned well above all other components. Solder R_{11} very close to R_{10} and run the other end direct to mixer pin 8. As R_{11} should have exactly the same total length as its LO counterpart, the $L_{10}-R_{11}-L_{11}$ line needs to be mounted slightly slanting with respect to the D_3-D_4 line. Ground L_{11} at the appropriate location, and check the outlook of the LO sections against Figs. 8c and 9.

PCB

Recheck all soldering joints at both sides of the PCB, and remove any stray bits of wire or solder. With a sharp appliance and a cotton bud dipped in 95% alcohol, remove all excess solder flux, visible as brownish matter, from etched surfaces in the RF input and mixer stage, do the same at the PLL section. If you have so far followed the instructions, terminal holes 1-8 incl. should still be open.

Enclosure

Fix K_1 securely by its four screws, whose heads should be at the inside of the enclosure. File off any protruding thread until it is flush with the socket flange.

Insert the completed board into the enclosure, making sure that the centre pin of the BNC socket rests on the RF input plane (L_1-C_1); file or cut off any excess pin length. Refer to Fig. 5b for the positioning of the board and make sure that the bottom lid can be pressed or screwed on without touching MX_1 .

Use a heavy-duty iron (>50 W) to solder the PCB into the enclosure; depending on the type of metal sheet, some pre-heating may be called for to be able to solder at all. Use an additional soldering iron to place the enclosure on the hot sur-

face of a thermostatically-controlled smoothing iron; you will find that once the metal surfaces are reasonably warm to the touch soldering becomes much easier.

Mount eight soldering pins in the terminal holes if the wires of the feed-through capacitors are not long enough.

Using the dotted lines on the PCB overlay as a guide, solder three 17 mm high metal screens onto the PCB component side (take care not to damage nearby parts). Note that the longest screen is to run right over IC_2 , so that a 20 x 4 mm recess hole should be made at the correct location.

If you have made your own metal enclosure, do not forget the top and bottom lids, which are to be screwed on after the box has been fitted with at least eight square brass nuts, soldered into the upper corners. A few additional nuts and screws along the enclosure side panels are, of course, good practice to make for an RF-tight unit. Finally, drill the top lid as shown in Fig. 5c.

Next time

Part two of the article in next month's issue will describe details of the vision and sound processing circuits, the power supply, and the S-meter driver. Also, the alignment of the IDU will be gone into, and measurement data relating to its performance will be presented and discussed.

Bu

Literature references:

- [1] Document D46: Choice of the first IF frequency range for DRS receivers. EBU Technical statement ref. EBU D46-1985 (E).
- [2] RF/IF signal processing handbook, volume 1. Mini Circuits, New York.
- [3] Satellite Cable and TV integrated circuit handbook Plessey Semiconductors.
- [4] Application note 56/SJ/00013 (SL1415) Plessey Semiconductors.

Important notice

Information on component availability for this project will be given in Part 2, to be published in next month's issue. Meanwhile, many parts are available from Bonex Limited; 102 Churchfield Road; Acton; London W3 6DH, telephone 01-992 7748; Universal Semiconductor Devices; 17 Cranville Court; Granville Road; Hornsey; London N4 4EP; telephone 01-438 9420, or Circuit; Park Lane; Broxbourne, Herts EN10 7NQ; telephone: (0992) 444111.

IDU for satellite TV reception

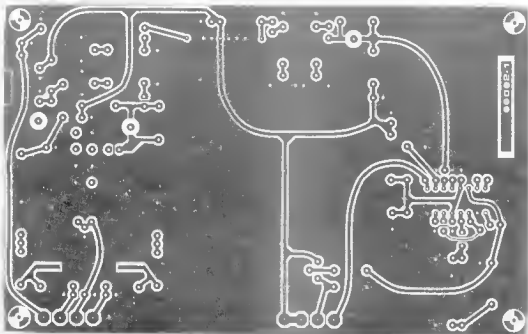
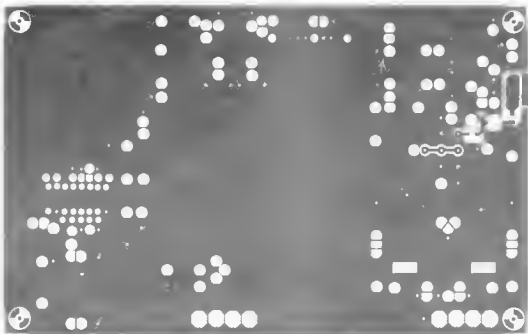

JOCKEYING FOR SUPREMACY IN EUROPE'S OWN SPACE RACE

by Tim Furniss

Within the next ten years, the European Space Agency (ESA) will be operating an autonomous space station known as Columbus. It will comprise manned modules and laboratories, free-flying platforms, and other equipment launched by the United States' Space Shuttle and the proposed European Ariane 5 rocket. It will be serviced by the European manned spaceplane, Hermes, and possibly by the British unmanned *Hotol* shuttle.

As a member of ESA, the United Kingdom will play an important role in these projects, not only with *Hotol*, but also particularly the free-flying platforms for Earth observation, astronomy, and materials processing. Britain's financial contribution to ESA is 12.9 per cent and its participation in mandatory ESA programmes represents 16 per cent of the effort and manpower.

There is a thriving space industry in the United Kingdom and this has been involved in the building and operation of over 50 satellites, 2000 sounding rockets, and over 100 ground stations. Unlike that of many European countries, British influence in space technology and commerce spreads beyond the continent itself, and especially to the United States of America.

British Aerospace (BAe) ¹⁶ is the largest manufacturer of communications satellites outside the United States and is a major contractor to American companies on a number of key projects. Although BAe tends to be the most familiar, several other companies are also actively engaged in the space industry on a large scale.

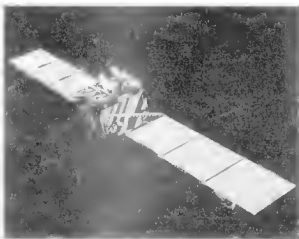

72

More versatile

These include GEC-Marconi ¹⁷ for communications payloads and ground equipment, while others involved are Ferranti ¹⁸, Logica, Klystrons, Centronic, Thorn-EMI, Racal, Software Systems, BAJ Vickers, and IMI Summerfield. These manufacture and supply other ground equipment, microwave tubes, detectors, solid state devices, digital data recorders, software, gyro packages, and rocket motors. BAe pioneered the use of three-axis controlled communications satellites, which are more versatile and can be built on a much larger scale for the multitude of developing applications, such as direct broadcast television, mobile and maritime communications, and business services. The company has developed a stable of communications satellite platforms: the European Communications Satellite (ECS), Eurostar, and Olympus. The ECS 2-Eutelsat series satellites being built by BAe have 12000 voice circuits, two television

channels, and two repeaters to handle business traffic. They have a 1 kW capacity. Three military communications satellites known as Skynet are being built, too. These are also based on the ECS "bus" and include a communications payload from GEC-Marconi comprising four super high frequency channels, two ultra high frequency channels for voice data and telex, and one extra high frequency experimental uplink. Power generation is 1.25 kW.

Aircraft phone calls

Three Eurostar satellites are being built for the London-based International maritime organization, Inmarsat, on a contract worth \$100 million. Producing 0.75 kW of power, the Inmarsat 2 satellites provide independent L band ship-to-shore and C band shore-to-ship communications, with 250 and 125 voice circuits respectively. Eventually they will also provide aircraft commu-

nications enabling passengers to take and make telephone calls on civil aircraft.

The Eurostar satellites can generate as much as 2.3 kW of power but this is weak compared with the world's largest communications satellite, Olympus, one model of which can generate 8 kW, enough to power 12 direct broadcast television channels.

The next British Aerospace satellite under development is called the Big Communicator. The concept envisages clusters of powerful communication satellites (comsats) sharing geostationary orbit, providing television broadcast and fixed and mobile communications services. Inter-satellite laser links will allow communications within and between clusters via gateway satellites. Three versions of the Big Communicator are planned, the largest being for direct broadcast television. This would generate 15 kW from a 50 m long solar array and carry 16 high power television channels. BAe also has a contract to build equipment for Intelsat 6, the next generation of satellites for the international telecommunications organization.

Spectacular data

The company produced significant Spacelab hardware which flew on Space Shuttle missions dedicated to Europe, the United States, and West Germany in particular. In 1983 to 85, twenty of the Spacelab pallets have been delivered to America's National Aeronautics and Space Administration (NASA). These are used as

the essential mounting points for equipment in the Shuttle payload bay. The European spacecraft Gioia, which had its rendezvous with Halley's comet last March, returning spectacular data, was built in Britain with BAe as the main contractor. The \$45 million contract is just one of a number of key science and applications satellites operated or planned for Europe and to be built using British expertise.

These spacecraft include the *Ulysses* international solar polar spacecraft, the European Remote Sensing spacecraft (ERS 1), *Exosat*, International Ultraviolet Explorer (IUE), Infrared Astronomical Satellite (IRAS), and the Geostationary Orbiting Satellite (GEOS 2).

The solar panels that will generate electrical power for the giant Hubble space telescope, hopefully to be launched by Shuttle later this year, were manufactured by BAe as a huge foldable array. The company expects to build a set of replacement panels under a \$7 million contract.

Britain is investing \$58 million in joint science and industry programmes covering remote sensing, data acquisition, processing, dissemination, and forecast. The Royal Aircraft Establishment's National Remote Sensing Centre at Farnborough co-ordinates this activity.

In the meteorological field, GEC-Marconi is developing Europe's first advanced microwave sounding unit to fly on a United States' National Oceanographic Administration Agency (NOAA) satellite in 1990. Britain is a world leader in satellite instrumentation for remote sensing spacecraft.

Close relationships

The British National Space Centre (BNSC), formed in 1985, will in future co-ordinate the country's burgeoning space industry. Based in London with a small staff, it will formulate a national space policy to be presented to the Government in June 86. To be effective, it should cover the next 15 years. The BNSC will need to establish close relationships with industry, including the non-aerospace sector, both in contractual development and exploitation, and commercial space operations. It needs to provide a coherent voice on space matters, seeking comprehensive rather than a fractional approach, and to consider its role in education and public policy. The centre's director-general is Dr Roy Gibson, who, as the European Space Agency's own first director-general, helped establish it and develop Europe's prestige in space. It is expected that Britain's space budget under his control will be doubled over the next two years to about \$300 million to reflect the increased importance the country places on space. Although the United Kingdom only plays a small part in the Ariane launcher programme — Avio, Badg, Ferranti, and Midland Bank's share represents just 2.4 per cent — BAe has proposed a revolutionary launcher to beat them all, including the proposed Ariane 5. *Hotol*, an initially unmanned spacecraft, will be the world's first single stage-to-orbit (SSTO) satellite launcher and the first to take off and land like an airliner. It will cut by half the cost of deploying satellites into orbit. Indeed, the measure may be greater than that. BAe says it could place a five tonne payload into low Earth orbit at a fifth the cost of current vehicles.

Complementary or replacement

The revolutionary engine for *Hotol* is designed by Rolls-Royce and will be dual-functioning. It breathes outside air like an ordinary airliner and mixes it with on-board supplies of liquid hydrogen during the initial climb through the atmosphere. *Hotol* then switches to internal fuel supplies of liquid hydrogen and liquid oxygen, once the air at altitude gets too thin to be usable.

It is expected to cost \$520 000 million to develop, and whether it goes ahead will depend on whether it is accepted by Europe as a complementary vehicle to Ariane 5 and Hermes, or even as a replacement for Hermes which does not meet with universal approval within Europe. So far, only about \$5 million has been forthcoming for a proof-of-concept study and Dr Gibson hopes to be able to present the *Hotol* case to ESA before the end of this summer. Although the French Hermes manned spacecraft has more short-term support, *Hotol* is conceived as compatible with the United States' Space Station and its eventual European counterpart. It will also be manned for some sorties. Ultimately, visionary engineers see *Hotol* as the successor to Concorde, carrying a passenger pod in its payload bay on a journey between London and Sydney, Australia, in 67 minutes.

Enormous potential

Like France, the Netherlands, West Germany, and Italy, Britain has a squad of astronauts, or more correctly, Space Shuttle payload specialists. Two of these are due

to fly Shuttle later this year and early in 1987, primarily to help in the deployment of Skynet 4A and 4B military communications satellites. They will begin British experiments into microgravity processing. The potential of this business is enormous and the BNSC is anxious to educate British industry as to its possibilities. Kodak Ltd, a subsidiary of Eastman Kodak in the United States, has already flown experiments on the Shuttle and a fluid physicist from the company may be joining a crew in 1987 to 88 to operate his own experiments. Clearly, commercial operations are some way off, perhaps 20 years away, but vital research and development work needs to be done in space now. This is an area where Britain has been slow to move but it has the capability to catch up with France and West Germany, which are already forging ahead in this field. (LPS)

* Tim Furniss is Associate Editor of *Space Report*

1 British Aerospace Dynamics Group, Space and Communications Division, Argyle Way, Stevenage, Hertfordshire, England, SG1 2DA

2 GEC-Marconi Instruments Ltd, Long Acres St, Albans, Hertfordshire, England, AL4 0JN

3 Ferranti PLC, Crewe Yb, Ferry Road, Edinburgh, Scotland, EH11 1PX

RF CIRCUIT DESIGN

* The first three appeared in the March, April, and May issues of *Elektron India*

The fourth in this series on RF circuit design* describes a superregenerative short-wave receiver that can be coupled to a frequency counter for an accurate read-out of the frequency of the received signal.

superregenerative short-wave receiver

A superregenerative receiver is provided with ample positive feedback so as to be capable of oscillation at the desired radio frequency. It is also provided with a means by which oscillations can be stopped or started at will. During normal operation, the relevant circuit is just oscillating.

Block diagram

From the block diagram in Fig. 1 it is seen that the RF signal intercepted by the aerial is fed to an RF stage, which not only serves to amplify the signal but also to decouple the aerial from the remainder of the receiver. The amplified signal is fed to a buffer and a detector stage. The output of the buffer may be used to drive a frequency counter to give a read-out of the received frequency. The demodulated output from the detector is passed through a low-pass filter

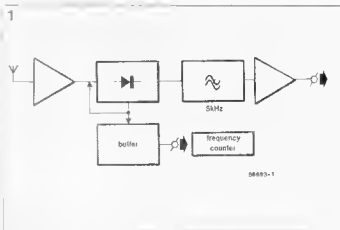

with a cut-off frequency of 5 kHz and then applied to an AF amplifier. The audio output is sufficient to drive a pair of headphones, but may also be used to drive a more powerful AF amplifier.

are quenched by the resistance of P_2 , depending on its setting, so that this potentiometer affords a means of bringing the tuned circuit just into oscillation.

The demodulated output at the source of T_2 is applied to low-pass filter $L_3-C_{13}-C_{14}-C_{15}$, which has a cut-off frequency of about 5 kHz. Since many short-wave stations operate at 5 kHz channel separation, the filter provides effective adjacent-channel suppression.

The audio signal is then amplified in T_4 and T_5 whose gain is sufficient to enable a pair of high-impedance headphones to be driven from the AF output across $C_{16}-C_{17}$. If the audio output is used to drive an additional AF amplifier, the value of C_{17} should be reduced to $1\mu F$.

The signal at the drain of T_2 is also fed to buffer T_3 , whose output may be used to drive an external frequency counter. This is a very useful means of obtaining a read-out of the frequency of the received signal, which makes operation of the receiver immeasurably easier.

Circuit description

With reference to the circuit diagram in Fig. 2, the aerial signal is applied across potentiometer P_1 , which enables the signal to be set to the correct level, as will be explained later.

MOSFET T_1 amplifies the input signal and decouples the aerial circuit. The amplified signal is applied to a detector, the G-D junction of T_2 , via circuit $L_2-C_2-C_3-C_4$, which is tuned to the frequency of the incoming signal.

Part of the RF signal is applied to the G-D junction of T_2 from where it is fed back inductively to the tuned circuit. As this feedback is positive, oscillations tend to be set up in the tuned circuit at the frequency of the received signal. These oscillations

For more details, visit <http://www.ijer.in>

Table 1: Winding data for L_2

Band	L2A (turns)	tap at (turns)	L2B (turns)
120 m	132	12	7.5
90 m	99	9	5.5
75 m	82.5	7.5	4.5
60 m	66	6	3.5
49 m	54	5	3
41 m	45	4.5	2.5
31 m	34	3.5	2.5
25 m	27	2.5	2
19 m	21	2	1.5
16 m	18	1.5	1.5
13 m	14	1.5	1
11 m	12	1	1

The core is a Type T50 6 RF toroid available from Cakut (telephone 0992 444111) or Bonex (telephone 01 982 7748), while the winding wire is 0.3 mm dia enamelled copper.

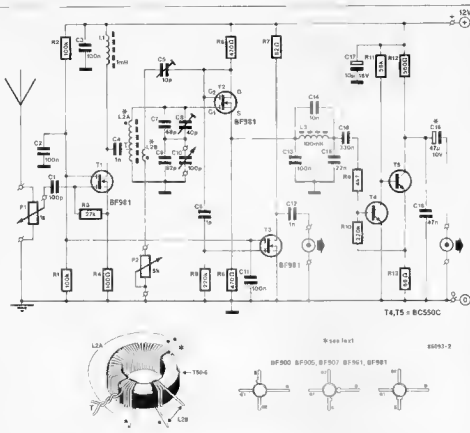

Parts list

Resistors

- R₁, R₂: 100 k
R₃: 27 k
R₄: 100 Ω
R₅, R₆: 470 Ω
R₇: 82 Ω
R₈: 220 Ω
R₉: 4k7
R₁₀: 220 k
R₁₁: 56 k
R₁₂: 560 Ω
R₁₃: 68 Ω
P₁: 1 k linear potentiometer
P₂: 5 k linear potentiometer

Capacitors:

- C₁: 100 p
C₂, C₃, C₁₂: 100 n ceramic
C₄: 5-10 n ceramic
C₅: C₁₁: 1 n ceramic
C₆: 10 p trimmer
C₇: 1 p
C₈: 68 p NPO
C₉: 40 p trimmer
C₁₀: 82 p NPO
C₁₃: 100 p variable capacitor
C₁₄: 10 n
C₁₅: 22 n
C₁₆: 330 n
C₁₇: 10 μF 16 V
C₁₈: 47 n
C₁₉: 47 μF 10 V (see text)

Semiconductors:

- T₁, T₂, T₃: BF961
T₄: BC550C
T₅: BF900 - BF905
BF907 - BF961
T₆: BC550C

Miscellaneous

- L₁: 1 mH
L₂: see text and Table 1
L₃: 100 mH
AF output socket
RF output socket
RF board 85000
Metal case of about 135 × 150 × 75 mm

Construction

The receiver is constructed on the Universal RF Board Type 85000, which is available through our Readers' Services. As it is an unpierced copper clad board with fifty-seven isolated islands and three isolated tracks, it is also available from most electronics retailers. A suggested component layout is shown in Fig. 3.

Chokes L₁ and L₃ are commercially available components, but inductor L₂ must be wound as shown in Fig. 2. The number of turns for the

various short-wave bands is given in Table 1. It is imperative for correct operation of the receiver that the coils are wound in the direction shown and that correct polarity is observed (this is facilitated by the large black dots in the circuit and on the coil drawing).

Operation

For optimum performance, the G-D section of T₂ should just oscillate. This is achieved by setting P₂ to roughly its centre of travel and ad-

justing C₅ till oscillations just occur. This is indicated by a whistle in the headphones or loudspeaker.

The input level is then set with P₁: if this is too high, cross modulation occurs, i.e. apart from the wanted station, others are also audible. If the aerial signal is too weak, the detector does not operate correctly, and the signal is hardly audible.

It may be necessary to adjust P₂ slightly before optimum performance is achieved: only when this is so, does the frequency counter indicate the frequency of the received signal.

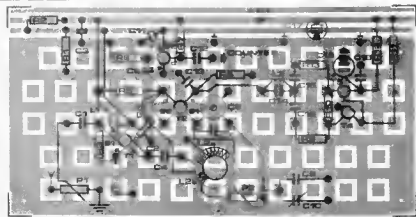

HOW MUCH LONGER WILL SILICON BE USED?

It sounds rather strange, against the background of the present development of microelectronics to ask how much longer silicon will be used. The first quantities of one-megabit dynamic memories using existing silicon technology have been announced recently while four-megabit dynamic memories are expected in 1988. These are the most outstanding current examples of the state of the art of silicon microelectronics. These developments in large-scale Integration (LSI) have been due to process technology or, to put it the other way around, it was mastery of process technology that made this progress in large-scale integration possible.

A reduction in costs per bit on an integrated device went hand in hand with this large-scale integration.

This is demonstrated by Fig. 1, which shows the evolution of costs per bit for the various generations of dynamic RAMs as "learning curves". The learning curves for one-megabit and four-megabit dynamic RAMs are estimated values. Before turning to the question of the limits of silicon technology and its replacement by gallium arsenide, we shall first briefly outline the development of silicon technology.

By the standards of microelectronics, silicon technology is a "very old" technology. It was 25 years ago, in 1961, that the first IC was developed by Kilby in germanium and one year later in silicon. This process led in only 25 years from a small number of transistors on a chip to more than one million transistors in regular logic devices on the one hand and to more than a hundred

thousand transistors on a chip in non-regular logic devices on the other hand. In other words, the complexity of the circuitry has increased by more than a hundred thousand times in this period of time.

After these developments, is a competitor now appearing on the horizon in the form of gallium arsenide? The worldwide market potential of gallium arsenide is estimated at 3.2 billion dollars for 1992, a considerable amount when one considers that, e.g., the German microelectronics market was worth about one billion dollars in 1985.

Against this background, one might after all be justified in asking how much longer silicon will be used. In order to answer this question we shall consider the following points.

- the mechanisms of substitution which result in the replacement of a technique or technology by another,

- the limits of silicon;
- the limits of integration techniques;
- the development of the market for silicon and gallium arsenide

Mechanisms of substitution

A technique or technology is only replaced by another under the following conditions:

- Techno-economic limitations of a technique become apparent, i.e. substitution results in cost savings.
- A faster evolution of an alternative technique is expected and at the same time a tendency towards greater efficiency in such a case a substitution is frequently made as a future investment.
- As well as the actual replacement of the existing technique, a new technique promises completely new applications. A substitution is made with a view to innovative potential.

Limits of silicon

In order to assess the limits of silicon and possibilities of the alternative material gallium arsenide, it is first necessary to consider the physical properties and also the technological status of the two materials. A comparison of the physical properties of the two basic materials reveals three salient factors.

- the much greater electron mobility of GaAs, which means that considerably faster circuits can be realized with GaAs;
- the much greater thermal stability of GaAs and greater resistance to radiation, which would be of particular advantage with very fast and highly integrated memories.
- a worse ratio of electron mobility to effective electron mobility in the case of GaAs, which also means that complementary electronics can be less easily used in GaAs than with silicon. The physical properties

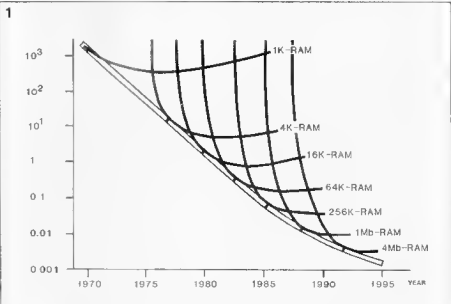

Fig. 1 The evolution of relative costs per bit for dynamic MOS-RAMs

only represent one side, however in order to make a final judgement we also have to take into account the state of the art in the two technologies. This has been done for silicon and GaAs in Table 1

If we look at this table, we see that the fault density for silicon chips is more than a thousand times less than for GaAs. This is due to a considerably greater uniformity, purity, and surface smoothness in the case of silicon chips; in other words, as a starting material silicon can be much better controlled than GaAs, which in turn results in far greater efficiency. We can also see that silicon chip surfaces are now more than 50 mm² in size, compared with 10-15 mm² for GaAs. In other words considerably larger and more complex ICs can at present be fabricated with silicon. On the basis of this table, it can be said that GaAs is at present technologically about a hundred times behind silicon in complexity, or more than two generations of components behind. The same conclusion is reached if one considers the evolution of the complexity of integrated circuits, as shown in Fig. 2. The thick line represents the evolution of the complexity of silicon circuits and the

Table 1

Technological status

	Si	GaAs
Chip diameter	6"	3"
Fault density	< 10 / cm ²	> 10 ⁴ / cm ²
chip uniformity		
chip purity		
surface smoothness		
Chip surfaces	> 50 mm ²	10-15 mm ²
Components IC	10 ⁶	10 ⁴

thin line the evolution of GaAs circuits. We can see how silicon has evolved to the four- and 16-megabit dynamic RAM, while GaAs has developed to the four-kilobit RAM. Fig. 2 does not show the production status of these circuits but the time at which the first design models were presented.

If we look at the two curves for silicon and GaAs, we have to conclude that, even if we assume a more rapid development for GaAs than for silicon, it will not attain the degree of complexity of silicon until 1995. Such a rapid development of GaAs is not to be expected and we should assume that the broken line with shorter strokes is more probable, so that even in the year 1995 we can expect a difference in complexity of more than ten

between silicon and GaAs. If GaAs is not going to catch up with silicon in the next ten years as regards complexity, what about the advantage of greater speed which components constructed on GaAs have?

An indication is provided by the evolution of the gate delays of integrated circuits based on silicon technology. As an example, Table 2 shows how gate delays in MOS processes in the Valvo plant (part of Philips GmbH in W-Germany) have developed from 1979/80 to 1986, together with the expectations for 1988.

Along with the reduction in the smallest geometries and the associated reduction in gate delays we can also observe a simultaneous increase in the size of the chip surface and in the number of

components per chip and per mm². This means, therefore, that not only the individual components on the chip have become faster, but that the total chip sizes and number of components have grown very rapidly. At present chips are produced which are 40-50 mm² in size, while chips up to 100 mm² are being developed and will be produced in 1987. This implies that from 1988 chips between 50 and 100 mm² will represent the state of the art. At the same time, the length of the circuit on such chips will also increase, so that a length of 40 mm on a chip of approximately 80 mm² will not be exceptional. If, however, we wish to determine the propagation delay on a circuit which is 40 mm in length and assume a value of 10¹⁰ cm/s for the signal propagation, we obtain propagation delays of 0.1 ns. This means, therefore, that with chips whose geometry is smaller than 1 μm and with chip surfaces of 100 mm² the speed of the components and the propagation delay between the components are in the same order of magnitude. From the above observations, it can be deduced that with highly integrated circuits it is no longer the properties of the components on the ICs which determine the speed of signal processing, but that the arrangement of the circuitry has a major influence. This also applies to GaAs. If, therefore, we substituted GaAs for all the silicon

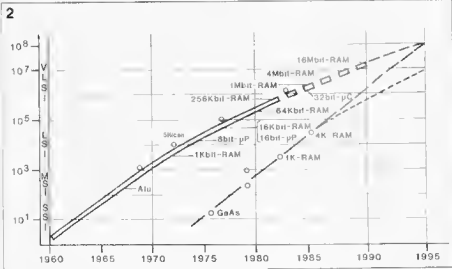

Fig. 2 The evolution and complexity of integrated circuits

components on a highly integrated circuit of this kind, we would scarcely alter their speed, as this is largely determined by the propagation delays between the individual components.

Limits of integration techniques

These observations show that in highly integrated circuits the speed cannot be the decisive factor for a changeover from silicon to GaAs and hence for the replacement of silicon technology. Hence, an assessment of whether silicon is likely to be replaced can only be made if we first answer the question concerning the limits of silicon technology. We must first clarify, therefore, whether silicon is more likely to come up against technological limits than GaAs. The question concerning the limits of silicon technology raises, however, questions concerning the general limits of integration techniques, which basically exist independently of whether one uses silicon or GaAs as the starting material. They do very much depend, however, on the smallest geometries that can be used and on the process technology required for these.

If, for example, we consider the yield loss in 64 K dynamic memories, approximately 70 per cent is due to random defects, i.e. defects which are caused by the lithographical and deposition processes. About 10 per cent is correlated to the structure, in other words is due to geometrical tolerances, and only about 20 per cent is connected with device parameters, i.e. directly linked with the processing of the silicon. The physical limits for vertical and lateral structures are approximately $0.05 \mu\text{m}$ for bipolar transistors and approximately $0.1 \mu\text{m}$ for

MOS transistors. The limits are set by the minimum dimensions of the space charge regions of the pn junctions, which at room temperatures and voltages of 1 V are approximately $0.03 \mu\text{m}$.

For the limits that can be reached in practice, we can make the following estimates. For lithography and etching techniques it is not possible in terms of production to go below structures of $0.1 \mu\text{m}$. Insulation requires geometrical distances of about $0.5 \mu\text{m}$. In order to keep the contact resistance at a tolerable level for components of less than 100 ohm, the contact holes should likewise have a diameter of more than $0.3 \mu\text{m}$. For the pitch, by which is meant the line width plus the spacing between it and the next line, it will not be possible to go below $10 \mu\text{m}$, above all for reasons of reliability. The limits that one can expect in practice are thus higher than the physical limits. It is not the physical properties of silicon which set the limits for integration techniques, but the processing limits in lithography, insulation, contact diameter and pitch.

How, then, is silicon technology expected to develop in the years 1990 to 1995?

Table 3 gives an estimate of what is expected in 1990 to 1995 on the basis of present technological knowledge. For the year 1990 structures of $0.3 \mu\text{m}$ are expected in the second generation, with chip surfaces between 100 and 200mm^2 . The difference between the first and the second generation can be seen in the lithographical process. While light-optical processes and steppers are still used for the first generation, the second generation will be based on processes that use X-ray lithography, as structures of $0.3 \mu\text{m}$ can no longer be realized with light optics. The limit for light-optical processes is put at about 0.5 to $0.6 \mu\text{m}$. Below this limit it will be necessary to use new processes such as X-ray lithography. Developments in this direction are already taking place and it is to be expected that they will be available for production in 1990.

These are projections for MOS devices. It is also interesting, however, to take a look at the right-hand side of Table 3, which shows the expected development of bipolar devices. We see here that geometries of $0.9 \mu\text{m}$ in the first generation and $0.5 \mu\text{m}$ in the second generation are expected. In the first generation this

results in limit frequencies for bipolar silicon components of 12 GHz and of 40 GHz in the second generation.

This means that on the basis of bipolar silicon technology with devices of the first generation, it is possible to construct systems with transmission speeds of 2.4 Gbits and up to 10 Gbits with devices of the second generation. The degree of integration, however, will be considerably lower than with MOS circuits. Silicon elements will, therefore, also be suitable for the construction of very rapid signal processing systems.

If we now return to the question which was posed initially, namely how much longer silicon will be used, and the related question of substitution, we should consider the three points:

1. substitution in order to save costs;
2. substitution as a future investment and
3. substitution for the purpose of innovation.

Point 1: costs per bit for silicon were reduced by more than a thousand times between 1970 and 1985

Point 2: integration techniques, and not the properties of silicon devices, will set the limits

Table 2

Development of gate delays

Example: MOS processes Volvo valve and semiconductor plant

Year	1979/80	1982	1984	1986	1988
Process	1100	700	500	300	"100"
Gate oxide thickness (nm)	110	70	50	30	10
Smallest geometry (μm)	6	3.5	2.5	1.5	< 1.0
Power delay product (pJ)	2.5	1.0	0.5	0.25	
Gate delay (ns)	3.0	1.0	0.4	0.20	< 0.10

Propagation delay

Length of circuit	$L = 10 \text{mm}$
Signal propagation	$V_s = 1 \times 10^{10} \text{cm/s}$
Propagation delay	$t = 0.1 \text{ns}$

Table 3

Expectations for 1990-1995

Master product level	Memory		MOS logic		Bipolar	
	1st gen	2nd gen	1st gen	2nd gen	1st gen	2nd gen
Width of structure	0.7 μm	0.3 μm	0.7 μm	0.3 μm	0.9 μm	0.5 μm
Chip sizes	100 mm ²	< 200 mm ²	100 mm ²	200 mm ²		
Transistor functions	5 x 10 ⁶	10 ⁸ 10 ⁹	10 ⁶	10 ⁸	10 ⁵	10 ⁷
Wiring levels	4	< 6	< 6	< 10	< 5	< 8
Limit frequency					12 GHz	40 GHz
Access time	40 ns	< 40 ns				
Data transmission rate					2.4 Gbit/s	10 Gbit/s

Point 3: GHz devices have already been developed with silicon. Further possibilities will open up after 1990/95.

Markets

Where, then, are the applications and markets for GaAs devices? The applications of GaAs are in those areas where on the one hand increased thermal resistivity, high resistance to radiation, and optical-electrical applications are called for. These are physical properties in which GaAs is clearly superior to silicon or properties which silicon does not possess. This means that the main area of application for GaAs is the military sphere, aviation, and the aerospace industry. In 1984, these ap-

plications covered approximately 46 per cent of the market share of GaAs, and it is expected that this market share will be extended to 56 per cent in 1992. These circuits will not be highly integrated circuits. In other words, they will be MSI circuits rather than VLSI circuits. Alongside this area of application, GaAs is also expected to be used for small-scale integration circuits as interlace circuits in the communication engineering industry for optical-electrical interfaces. The areas of application will require medium and small-scale integrated circuits, but not system integration with corresponding VLSI circuits. But then are the figures given at the beginning reliable, namely that the market potential for

GaAs in 1992 will be worth about 3.2 billion dollars? These figures are right according to the information available at present. They show that GaAs will only account for a small share of IC consumption, while silicon will continue to dominate and provide the basic material for large-scale integration.

Conclusion

To sum up, we can say that GaAs will not become a substitute for silicon in large-scale integration or in system integration. It will be possible to realize some individual functions better in GaAs than in silicon. These functions, however, will have to be very critically examined, as realizing certain functions in a different technology

always raises questions concerning interfaces. For example, the position of the interface between silicon and GaAs in systems for optical communications will very much determine the success or failure of a new system. Not only physical properties will necessarily play a decisive role in this, but also the technological practicability of the whole system. The transition from a technology that is mastered to a new and relatively difficult technology always involves a large number of technical risks. It may thus be a better prospect to use a familiar and perfected technology, even perhaps at the cost of "technical elegance", and only to use the other technology where it is absolutely necessary for making a system more efficient and more rapid. The choice of technology or the question of the interface between two technologies will thus be decisive for the success of complex systems. Realizing functions in GaAs which cannot be realized in silicon does not represent substitution. Questions of this kind are of course excluded from any consideration of the question of substitution.

Philips Report No. 10.759E (from a speech by Dr Peter Draheim, Valva, Philips GmbH, Federal Germany).

ELECTRONIC AND MAGNETIC QUANTITIES.

Quantity	Symbol	SI Unit	Abbr	Quantity	Symbol	SI Unit	Abbr
electric current	<i>I</i>	ampere	A	reluctance	R, R_m	reciprocal henry	1/H
electric charge quantity of electricity	<i>Q</i>	coulomb	C	permeance	μ	henry	H
electric field strength	<i>E</i>	volt per metre	V/m	phase displacement	ϕ		
potential difference	<i>U</i>	volt	V	winding	<i>N</i>		
electromotive force	<i>E</i>	volt	V	impedance	<i>Z</i>	ohm	Ω
electric flux	ψ	coulomb	C	reactance	<i>X</i>	ohm	Ω
capacitance	<i>C</i>	farad	F	quality factor	<i>Q</i>		
magnetic field strength	<i>H</i>	ampere per metre	A/m	admittance	<i>Y</i>	siemens	S
magnetic potential difference	<i>U_m</i>	ampere	A	susceptance	<i>B</i>	siemens	S
magnetomotive force	F, F_m	ampere	A	active power	<i>P</i>	watt	W
magnetic flux density	<i>B</i>	tesla	T	apparent power	$S, I^2 R$	watt	W
magnetic flux	Φ	weber	Wb	reactive power	$Q, I^2 X$	watt	W
self inductance	<i>L</i>	henry	H	wavelength	λ	metre	m
mutual inductance	M, L_{12}	henry	H	frequency	ν, f	hertz	Hz
coupling coefficient	<i>k</i>			angular frequency	ω	hertz	Hz
velocity of light in a vacuum	<i>c</i>	metre per second	m/s	period	<i>T</i>	second	s
resistance	<i>R</i>	ohm	Ω	time constant	τ	second	s
resistivity	ρ	ohm metre	Ωm	thermodynamic temperature	<i>T</i>	kelvin	K
conductance	<i>G</i>	siemens	S	energy	<i>E</i>	joule	J
conductivity	$\lambda, \gamma(n)$	siemens per metre	S/m				

DARK-ROOM EXPOSURE METER

No photographer can work properly in his dark-room without some sort of light meter. The instrument proposed here is not expensive, easy to build, and, apart from the exposure time, it indicates the contrast in relative light values.



In spite of its simplicity, the meter is accurate enough for virtually all requirements. Moreover, it is constructed from standard components throughout, with the possible exception of the Type BPW21 photodiode. Operation of the meter is simplicity itself: a push button for normal exposure measurement; another push button for contrast measurement; and a microammeter for the read-out.

Circuit description

The first notable aspect of the circuit diagram in Fig. 1 is that three different levels of supply voltage are required: +2 V, +5 V, and +9 V. At first sight this may seem extravagant, but it is not really as will be seen later. Moreover, the three levels are obtained relatively easily. The +9 V is provided direct by the battery; since the total current consumption does not amount to more than 15 mA, a standard PP3 will do nicely. The +5 V supply is derived from the bat-

tery via a Type 7805 voltage regulator, while the +2 V supply is provided by a voltage divider (R_1 - R_2) and an opamp (IC₁).

The exposure meter is based on a well-known principle: the photo-voltaic effect. This effect causes certain semiconductor diodes to produce a forward voltage when they are illuminated. This voltage changes in direct proportion to the logarithm of the causative change in light flux provided the diode is terminated in a high impedance. This proviso is met in the present circuit by terminating the photodiode, D₁, into opamp IC₁.

It should be noted that the spectral sensitivity of the BPW21 is very similar to that of the human eye. The maximum sensitivity of the diode and the human eye are about the same, but the BPW21 has a somewhat larger bandwidth.

The diode voltage is amplified and inverted in three opamps: IC₂, IC₃, and IC₄, and then applied to the series combination of the meter, M,

resistor R_3 , and preset P₁. In this application, the meter should have a logarithmic scale (see Fig. 2).

It should be noted that this exposure meter works in an exactly opposite way from that in a camera, because the present meter should not indicate the amount of light, but the required period of illumination. Therefore, when the light flux is large, the diode voltage is high, and the voltage across the meter is low. Conversely, if there is but little light, the meter will deflect strongly. Diodes D₂ and D₃ serve to compensate for the variation of the diode voltage with temperature. In the prototype the variation resulted in a difference of only half a stop for every 7 °C: a perfectly satisfactory value, the more so when it is remembered that the temperature in a dark room must be kept fairly constant. As long as the three diodes are not heated unnecessarily when the instrument is handled, all will be well. Potentiometer P₁ affords compensation for different paper sensitivities,

because, in conjunction with R_1 , R_2 , R_3 , R_4 , R_5 , it can add a small direct voltage to the measured voltage. Since the meter scale is logarithmic, this added voltage manifests itself as a multiplication of the indicated time. The effect of P_2 is the same as that of P_1 , but this control is only set during the initial calibration of the instrument.

Contrast measurement is effected with the aid of electronic switches ES_1 , ES_2 , and ES_3 . When the contrast push button, S_1 , is open, ES_1 will also be open, while ES_2 and ES_3 will be closed (situation as shown in Fig. 1). The circuit operates as an exposure meter as described. In this state a light section of a negative should be measured.

When S_1 is pressed ES_1 and ES_2 open and ES_3 will close for a short time (at the instant—after ES_3 has opened—that C_3 is charged via R_7 and R_{14} , junction C_3 - R_{14} will go high, which causes ES_1 to close, once C_3 is charged, junction C_3 - R_7 will go low, and this causes ES_2 to open again). During the time that ES_1 is closed, C_1 is charged to the potential then present at the output of IC_1 . The voltage across the microammeter then drops to zero, so that the pointer does not deflect at all. Even when ES_1 opens again after a short while, the potential across C_1 is maintained.

With S_1 still depressed, hold the photodiode under a dark part of the negative the meter will deflect again, but the voltage across C_1 is now deducted from the measured value. In other words, the meter now indicates the contrast (in LV) between the first and second measurements, i.e. between the light and dark parts of the negative.

Since a difference of one LV (light value) corresponds to a doubling (or halving) of the light flux, the contrast scale of the meter is calibrated linearly as shown in Fig. 2.

Construction

The circuit is best constructed on a small piece of single-sided Veroboard. As far as the enclosure is concerned, any small one will do, as long as the board, microammeter, and operating controls can be fitted neatly. The controls should, of course, be easy to reach and operate. The photodiode should be

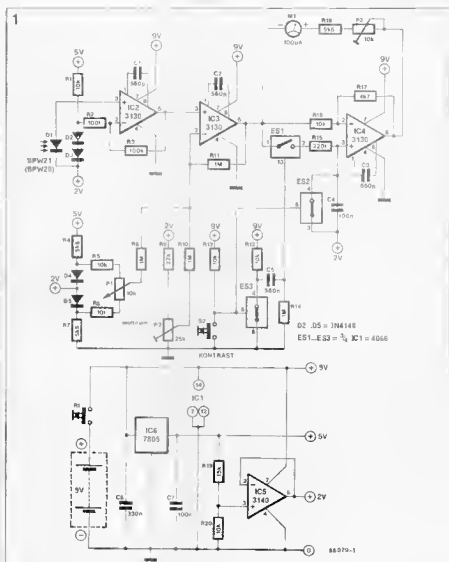

mounted in a manner which ensures that the light from the enlarger reaches it freely. Diodes D_1 and D_2 should be placed as close as possible to the photodiode, so as to keep temperature differences between the three as small as possible.

Setting up

Set P_1 to the centre of its travel. Using photographic paper of average sensitivity, make a test strip that is correctly exposed with an exposure time of 2 seconds. The lowest stop number should be used, and the correct illumination obtained by

adjusting the height of the enlarger. Place the exposure meter on the base of the enlarger and disperse the light, for instance, by holding a piece of opaque paper in front of the lens. Adjust P_2 until the microammeter indicates 2 s. Select the fourth lowest f-stop and adjust P_1 until the microammeter reads 32 s (= contrast of 4 LV).

Finally

A calibrated scale needs to be made for P_1 corresponding to the sensitivities of different types of photographic paper. This requires the making of a lot of test strips, but such a scale will be found very useful in practice for a long time to come.

For contrast measurements, the position of P_1 is irrelevant (as long as it is not changed between the two measurements).

Fig. 1 The circuit diagram of the dark room exposure meter

Fig. 2 Swoosetee scale for the microammeter logarithmic for time, and linear for contrast



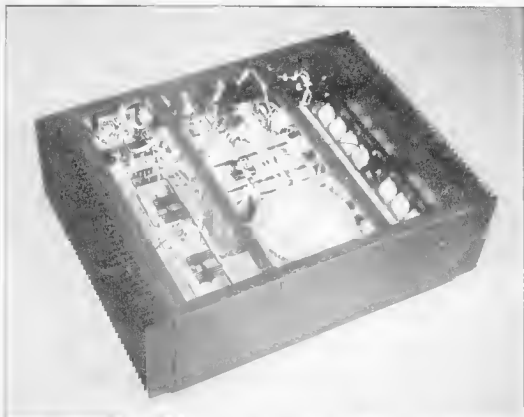

HIGH-POWER AF AMPLIFIER — 2

After last month's discussion of the power output boards and associated power supply, this concluding article details the design and construction of the bridge/stereo preamplifier, driver stage power supply, soft turn-on and protective circuitry, as well as an effective fan control section. In addition, a variety of illustrative material is offered as an aid to understanding the amplifier's mechanical construction.

Driver stage power supply

The circuit diagram of the combined ± 90 V and ± 12 V supply unit originally given in June issue of *Elektor India* unfortunately contains a small error and a correct version of it is, therefore, reproduced here. The ± 90 V driver stage supply is quite straightforward; it is capable of

supplying up to 2×100 mA. The open circuit voltage of this section is about ± 100 V. The ± 12 V supply is so conventional as to make any description of it unnecessary.

Preamplifier

In order that the amplifier can be switched from $2 \times 250/500$ W stereo to 1000 W mono operation in a

bridge-connected configuration, the two power output boards must be driven with the normal left and right signals (stereo) or complementary phase signals (bridge set-up); both configurations are supported by the special preamplifier shown in Fig. 8. It can be seen that the antiphase signals come from opamps A₂ and A₄; the former functions as a non-inverting, the latter as an inverting amplifier stage. In order to ensure simultaneous clipping levels and

identical overall response for both power output boards, all resistors in the circuit must be 1% tolerance, high stability metal film types. The preamplifier inputs are balanced, so that the amplifier can be driven direct from low-noise, balanced cables, as is customary in large PA systems.

However, where unbalanced inputs are preferred, the negative input terminals may simply be grounded. Stereo potentiometer P_1 should be a high quality type, since any tracking error may readily lead to differences in output power from the amplifier's left and right channel. In some cases, a linear stereo potentiometer may, therefore, be preferable over a logarithmic type.

Soft turn-on and protective circuitry

The power-on delay circuit, shown in Fig 9, has its own DC supply, which operates off the AC_2 voltage from Tr_2 . When the mains switch is closed, C_7 is charged rapidly, and C_8 provides an approximately one second long, high logic level at the inputs of N_1 , whose inverted output level disables Tr_1 . Therefore, Re_1 will not be energized until one second or so after power-on, and the initial turn-on current for Tr_2 and Tr_3 is forced to flow through "brake" resistor R_{50} , whose function has already been explained in last month's article on the high-power AF amplifier — refer to Fig. 5 and the section on power supplies in that article. After the initial second has elapsed, R_{50} is short circuited by the Re_1 contact, and Tr_1 and Tr_3 receive the full mains voltage across the primary windings. The red LED goes out, and the yellow one lights to indicate the second interval of 1.5 seconds before C_9 is charged, N_2 supplies a low and N_1 a high logic level, and Re_2 is energized, connecting the loudspeakers to the amplifier outputs; at which moment the yellow LED goes out and the green one lights, indicating that the amplifier is fully operational. The outlined power-on timing sequence prevents blown fuses as well as loudspeaker destruction.

When the amplifier is switched off, the voltage across C_7 is the first to break down, since this smoothing capacitor is rated at only 100 μ F. The resulting low logic level at the second input of N_1 causes Tr_1 to deactivate Re_2 , disconnecting the loudspeakers from the amplifier outputs. At the same time, Re_1 is deactivated, since the base current for Tr_1

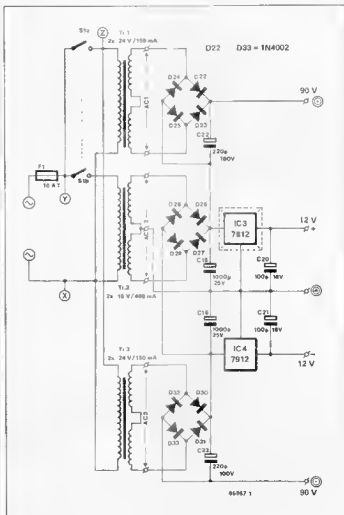

Parts list for the circuit combined - 90 and - 12 V supply

Capacitors (electrolytic)

C_{18}, C_{19} 1000 μ , 25 V

C_{20}, C_{21} 100 μ , 18 V

C_{22}, C_{23} 220 μ , 100 V

Semiconductors

D22, D33 1N4002

IC3 7812

IC4 7912

Miscellaneous

F1 10 A fuse; slow

Fuseholder for panel

mounting

S1 double pole mains

switch 3A 250 V

Tr_1, Tr_3 2 x 24 V

150 mA

Tr_2 2 x 15 V, 400 mA

T0220 style heatsink for

IC3

Relevant section on

PCB Type 88067

Soldering pins and wire

as required

Three pin mains chassis

plug rated at 240 V

AC, 10 A

Fig 8 Circuit diagram of the switchable stereo bridge preamplifier. Connect the input terminals to ground to suit operation with unbalanced drive signals

8

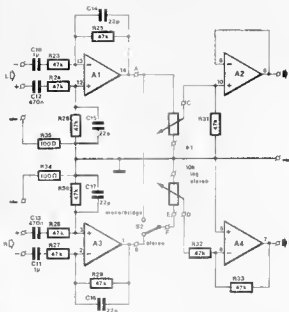

A1, A4 = IC2 = TL074

86067-2

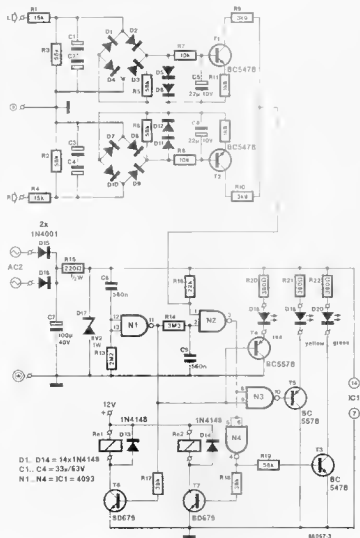
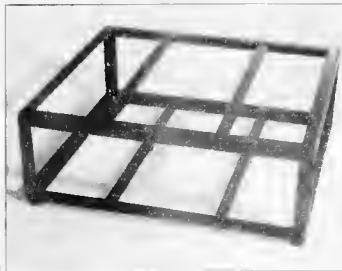

Fig. 9 Combined circuit diagram of the output IC monitor and the essentially non-inductive relay driver for 120-watt 120 V LEDs.



has dropped. All LEDs go out, but the large capacitance of the ± 75 V supply ensures the prolonged presence of a slowly falling supply voltage for the amplifier output stages, so that the loudspeakers are protected against clicks at power-off. The relays used in this design should be capable of switching and sustaining high contact currents; both R_{e1} and R_{e2} should be rated at least 10 A in this respect, and suitable types may be found in the parts list with this article.

The proposed circuit with T1 and T2 keeps tabs on the presence of any dangerously high direct voltage levels at the amplifier outputs. Should anything be amiss in this respect, the input of N3 is pulsed logic low and R_{e2} is consequently deactivated. The green LED goes out and the yellow one lights in order to signal the fault condition.

Fan control

A powerful fan capable of helping to keep the heat sink temperature within reasonable limits is an indispensable item in case the amplifier is to output continuous high power levels, such as may be required in applications involving multi-loudspeaker setups to cater for considerable sound pressure levels (SPL) at large sites.

Depending on the task assigned to the amplifier, the fan control circuit shown in Fig. 10 may be constructed single or two times over (one or two fans, as required).

If a single fan is used, both T₅ and T₄ are required as temperature sensor devices, because it is preferable to monitor both heat sinks simultaneously. Do not forget to fit these sensors with insulating washers, bushes and heat conducting paste.

Two fans require two control circuits, and T₅ can be dispensed with in each of these: a single sensor T₅ suffices. Operation of the fan control circuit is straightforward; the Type BD139 transistors function as heat-sink-mounted temperature sensors. Given an ambient temperature of 20 °C and a collector current as defined with R_{e1} the base-emitter voltage (U_{be}) of the Type BD139 is typically about 625 mV. The fact that U_{be} is temperature dependent to the extent of falling 2 mV per degree of temperature rise is put to good use in the present fan control circuit. The base of the sensor transistor is arranged to be at a voltage between 350 and 640 mV set by P₁. Assuming that P₁ has been set to a base voltage of 565 mV, then the sensor transistor will not conduct until its U_{be} has

ped. 500 nV. After wo...
 when the transistor junction tem...
 erature has risen to 50 °C. At this...
 point, T_{be} is driven and the fan is...
 switched on via the R_{e1} contact. This...
 condition is signalled by LED D_{e1} ,...
 which should have a suitable colour...
 as to be readily spotted from a...
 distance. Resistor R_{e1} effects positive...
 feedback which ensures a hysteresis...
 of about 5 °C, necessary to keep the...
 delay from chattering as U_{be} ap...
 proaches the preset value.

A common PCB

Any of the discussed circuits are fitted...
 to a single PCB as shown in Fig 11,
 with the exception of transformers...
 T_1 , T_2 , T_3 , the relays, T_4 and T_5 (the...
 latter as required in the specific fan...
 arrangement). Where this is desir...
 able, the ready-made PCB for this...
 project may be cut into sections for...
 mounting in suitable locations in the...
 amplifier cabinet.

Fitting the parts should not present...
 problems, the constructor need...
 merely decide on the number of fans...
 and associated control circuits;
 either one, two, or none.

Amplifier construction and wiring

The unit configuration shown in...
 Fig. 12 may be studied and copied in...
 case the amplifier is to operate with...
 out fans. It can be seen that the large...
 heat sinks form the sides of the cab...
 net; the location ensures sufficien...
 t cooling for relatively low power...
 use of the amplifier.

However, heavy duty applications re...
 quire the use of a special combin...
 ation of heat sink and fan as illu...
 strated in Fig 13. Note the cooling...
 fins at the inside of the tube-like...
 construction, at one side of which...
 the fan has been mounted to provide...
 a continuous stream of fresh air...
 passing along the inside surface of...
 the tunnel.

All supply, relay and loudspeaker...
 wiring in the amplifier should be...
 made with heavy-duty stranded wire...
 having a cross-sectional area of...
 2.5 mm² or more.

It would seem advisable to start the...
 wiring job with the connection of...
 the low power transformers T_1 , T_2 ;
 refer to the relevant diagram and...
 note the use of the separate switc...
 h section S_{b1} for T_2 . Now connect...
 the driver supply board and verify...
 the presence of about ± 100 V (open...
 circuit voltage) and ± 12 V. Discharge...
 the smoothing capacitors via 10 k

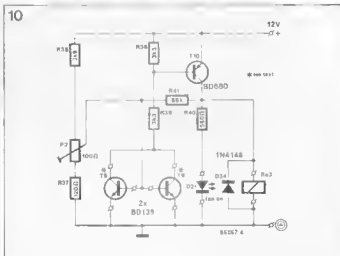
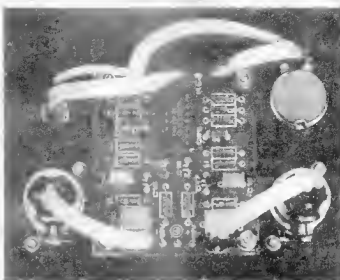
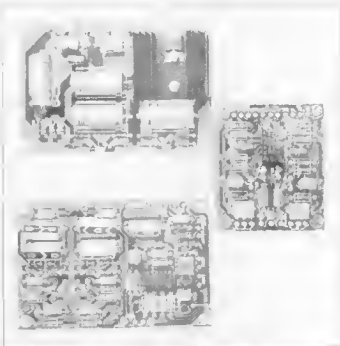

Fig. 10. Adjustable and ch...
 sioned to suit...
 individual re...
 quirements. If...
 the number of...
 fans, this semi...
 driven control...
 circuit safe...
 quares again...
 heatsink tem...
 peratures that...
 endanger the...
 life of the po...
 wer MOSFETs in...
 the amplifier ou...
 tput stage.

Resistors

R22, R33 - 47 k, 1%*
R34, R35 - 100 Ω
P1 - 10 k potentiometer,
logarithmic*

Capacitors

C10, C11 - 1 μ MKT
C12, C13 - 470 n
C14 - C17 - 22 p
C24, C25 - 100 n

Semiconductor

IC2 - TL074

Miscellaneous

S2 - single pole toggle
switch
Relevant section on
PCB Type 06067
Soldering pins as
required
2 off 3 way
Canon-XLR plugs
* see text

Parts list

DC monitor and power
on delay (Fig 9)

Resistors

R1, R2 - 15 k
R3 - R5 - 56 k
R7, R8 - 10 k
R9, R10 - 3k9
R11, R12 - 1k8
R13 - 2M2
R14 - 3M3
R15 - 220 Ω , 0.5 W
R16 - 22 k
R17, R18 - 25 k
R19 - 56 k
R20 - R22 - 330 Ω

Capacitors

C1 - C4 - 33 μ , 63 V
electrolytic
C5, C6 - 22 μ , 16 V
electrolytic
C7 - 100 μ , 35 V,
electrolytic
C8, C9 - 560 n

Semiconductors

D1 - D4 - 1N4148
D15 - D16 - 1N4001
D17 - zener diode
8V2 1.3 W
D18 - LED red
D19 - LED yellow
D20 - LED green
T1 - T3 - BC547B
T4, T5 - BC557B
T6 - T7 - BD679
IC1 - 4093

Miscellaneous

Re1 - high power relay
coil voltage 12 V;
single contact, rated at
10 A 240 V
rel g Schrack Type
RL200012, base Type
RN78755*1

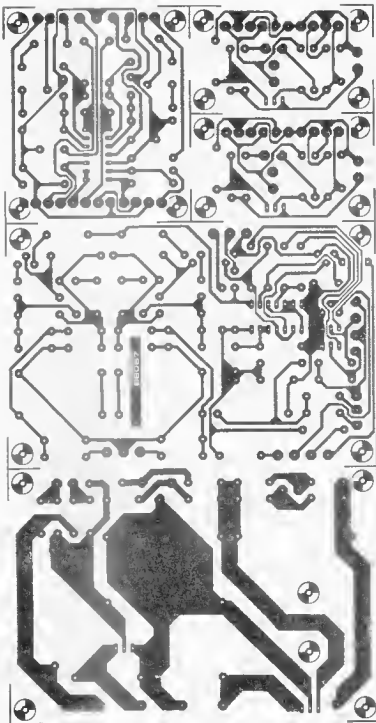

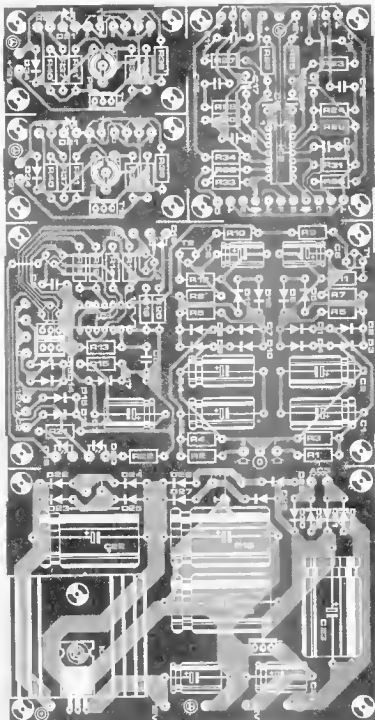

R22 high power coil voltage 12 V
2 pole change over contacts rated at 16 A 80 V te g
Schrack Type RX020012)
Relevant section on PCB Type 86067
Soldering pins as required

* Available from STC Electronic Services, telephone 102791 26777

Parts list
Fan control (Fig. 16)

Resistors

R31 3kΩ
R3 120 Ω
R16 R20 3k3
R61 560 Ω
R41 68 k
P2 100 Ω preset

Semiconductors

D21 - LED*
D24 1N4148
T6 T8 BD139
T1 BD680

Miscellaneous

Res 12 V relay contact rating 240 V AC 1 A
Axial fan(s) as required e.g. EBM Type W25075 AA13 02
STC Electronic Services telephone 102791 26777*
Soldering pins as required
Relevant sections on PCB Type 86067
Insulating washers and bushes as required for T6 and T8
* see text

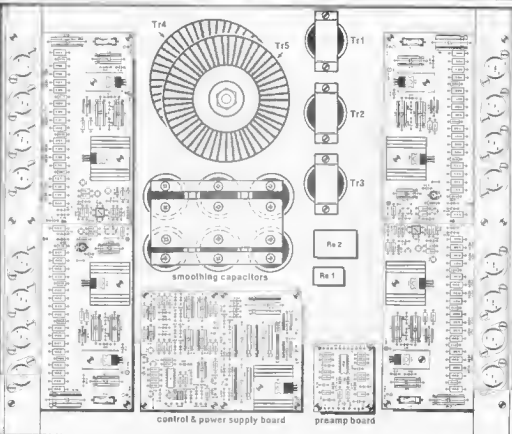

86047-6

1W resistors, before proceeding with the connection of the power-on delay and protective circuitry. Note the ground connection on the power-on circuit; it should be run direct to the centre tap of Tr₂ to prevent the 10 ms charge pulse for C₁ from causing hum on the supply lines to the preamplifier.

The power-on and protective circuits may now be tested; switch on the mains and verify the delayed action of Re₁ and Re₂ in that order. Applying a direct voltage, e.g. the + or -12 V supply rail, to either one of the protection DC sense inputs L or R should immediately deactivate loudspeaker relay Re₂, the ground terminals for delay and DC sense circuits should be temporarily connected for this test. When wiring the L and R inputs to the loudspeaker lines, remember to make the connections direct to the amplifier outputs, that is, not behind the Re₂ contacts!

The construction is next proceeded with the wiring around the toroidal power transformers Tr₄ and Tr₅ taking due care not to confuse the X, Y and Z points. Brake resistor R₃₀ should be mounted on a set of soldering tags. Also remember to fit all mains wiring in an absolutely safe

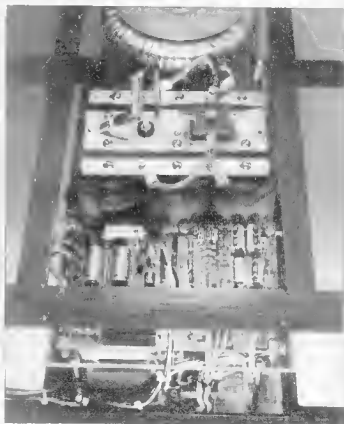
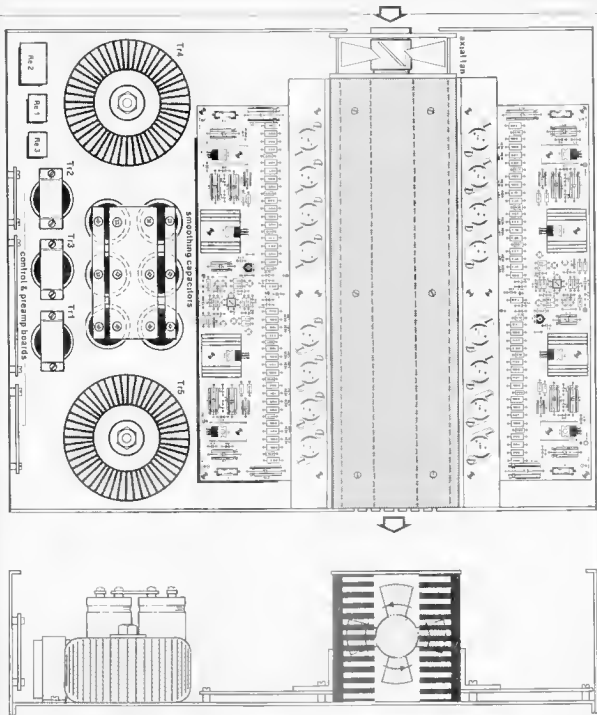

Fig.
5073
40-1
11-1
11-2
11-3
11-4
11-5
11-6
11-7
11-8
11-9
11-10
11-11
11-12
11-13
11-14
11-15
11-16
11-17
11-18
11-19
11-20
11-21
11-22
11-23
11-24
11-25
11-26
11-27
11-28
11-29
11-30
11-31
11-32
11-33
11-34
11-35
11-36
11-37
11-38
11-39
11-40
11-41
11-42
11-43
11-44
11-45
11-46
11-47
11-48
11-49
11-50
11-51
11-52
11-53
11-54
11-55
11-56
11-57
11-58
11-59
11-60
11-61
11-62
11-63
11-64
11-65
11-66
11-67
11-68
11-69
11-70
11-71
11-72
11-73
11-74
11-75
11-76
11-77
11-78
11-79
11-80
11-81
11-82
11-83
11-84
11-85
11-86
11-87
11-88
11-89
11-90
11-91
11-92
11-93
11-94
11-95
11-96
11-97
11-98
11-99
11-100



and sound manner, so as to prevent possible lethal contact with any of the live points or wires.

A common earth point should be created at the ground terminal of the ± 75 V power supply, and this point should serve as the common earth return terminal for the loudspeaker wires in the stereo set-up, as well as the point from which the earth return (o) wire to the amplifier boards is run. Since this wire does not carry high currents, it need not be as thick as those for the ± 75 V rails. The



Fig. 13
Suggested heat sink arrangement for heavy-duty amplifier use.

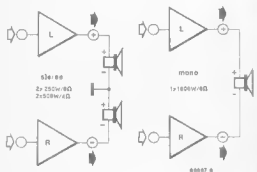

ground terminals on the power amplifier boards, marked @, are next wired to the corresponding terminal on the driver supply board.

Since this point is also the ground terminal for the preamplifier board the signal wires between drivers and preamplifier should have their screens connected at the preamplifier end only.

The preamplifier ground input connections should be isolated with respect to the amplifier enclosure, and it is best to purchase two Type XLR connectors for this purpose (see parts list).

The amplifier's metal enclosure is connected direct to the mains earth line, as well as to the central ground terminal on the ± 75 V supply, using a 100 Ω resistor.

Finally, the construction of the high-power AF amplifier is illustrated with a number of photographs in this article, offering suggestions regarding possible enclosure construction and wiring methods (note the purpose-welded framework to hold the PCBs and heavy parts). Keep in mind that a sound mechanical construction is paramount to reliability and the ability to resist the kind of rough treatment an amplifier of this type is likely to be forced to endure.

Testing

After the amplifier has been completed, it is time to check its correct operation. In case you have been patient enough not to test the power output boards as yet, start off with replacing the 6.3 A fuses with 22 Ω 1 W resistors, and turn the quiescent current presets (P₁) fully anticlockwise. After switching on the amplifier, no voltage should be measured across these fuse substitutes. Should the

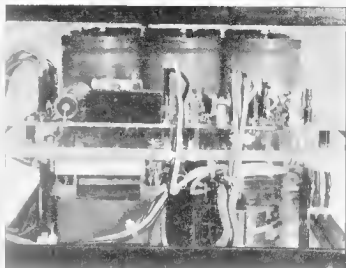

loudspeaker relay remain off after the power-on delay, there is bound to be something amiss in the MOSFET output stage. Now check all supply voltages in the amplifier before proceeding with setting the quiescent current to 400 mA per 75 V supply rail (i.e. 0.4 V across each 'fuse'; 100 mA per transistor). The voltage levels given in circuit diagram Fig. 3 may now be checked, at the same time pay due attention to equal current distribution among the power MOSFETs, i.e. each group of parallel-connected source resistors should drop about 25 mV. Large differences in this respect may cause some of the transistors to provide all the power to the load, while others are idle.

Leave the amplifier switched on for some time to verify its thermal stability under quiescent current conditions. The remainder of the test procedure includes checking the output power capability and distor-

tion-free amplification within the frequency bands and signal level range given in the feature list of article (See Elektor India June 86)

There is one final point to make concerning the loudspeaker polarity in the stereo set-up (Fig 14), note the reversed polarity of the loudspeaker at the R output; this is the result of the 180° phase turn occurring in the inverting opamp in the preamplifier. However, if the wiring to the loudspeaker output sockets is made as shown in Fig 14, this oddity need not concern the user once the amplifier is fully operational.

Finally, the bridge configuration requires the amplifier to be driven monaurally at the left-hand channel input.

TS/TW

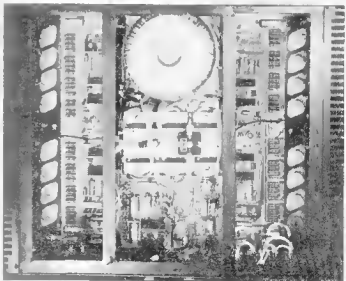

When a multimeter is used for measurement, there can be two types of errors: genuine measuring errors, and errors which are not really measuring errors!

Even the specified technical data for electronic components allows for deviations as high as 10%. The carbon film resistors show tolerance values of $\pm 5\%$ or $\pm 10\%$. Capacitors with $\pm 10\%$ tolerance are considered to be very good. Transistors are tested after manufacture and classified according to their current amplification factor. This classification is designated by a letter or a number appearing after the type number of the transistor, (e.g. BC147B). In spite of this classification, the values of the current amplification factor within a group deviate from each other by more than $\pm 30\%$. In case of components like electrolytic capacitors, the specified values may also change with time.

Nevertheless, most of the circuits function correctly in spite of considerable component tolerances. Where accuracy is required, suitable compensations must be provided.

Whenever we find that a measured value deviates from a specified value, we must first see if this is due

Measuring Techniques

Chapter 3

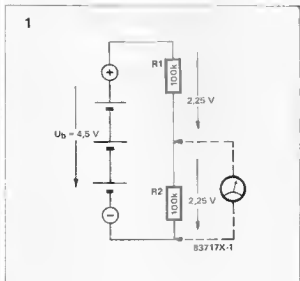

to component tolerance. We must also consider whether the deviation has an effect on the functioning of the particular circuit. It is not possible to make any generalised statement about the effect of such deviations on the circuit performance, because the deviations vary from component to component and the effect is different for different circuits.

Let us take an example to see how a genuine measuring error can occur irrespective of the actual measuring accuracy of the measuring instrument.

Figure 1 shows a voltage divider made of two 100K Ω resistors and a 4.5V battery connected across the

2

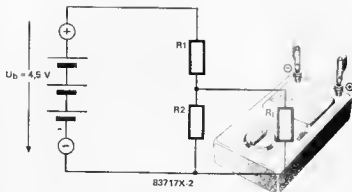

Figure 1
A potential divider made of two equal resistors of 100K Ω each. The expected voltage across R_2 is 2.25V.

Figure 2
When a multimeter is connected to measure the voltage across R_2 , its internal resistance R_i is effectively connected in parallel with R_2 and thus affects the equivalent resistance across which the voltage gets measured.

combination. Theoretically, these two resistors must divide the battery voltage of 4.5V into $2.25 + 2.25$. Now let us connect a multimeter across R2 and measure the voltage across R2. Surprisingly it is only 1.8V. The cause of this measuring error is the current drawn by the multimeter itself. This current is the result of the internal resistance of the multimeter. This value can be calculated from the Ohms per Volt specification of the multimeter. The internal resistance is obtained by multiplying the ohms per Volt value by the measuring range in volts. Thus a multimeter with $20K\Omega$ per Volt being used on 10V range will give the internal resistance R_i as follows

$$R_i = 10V \times 20K\Omega/V = 200K\Omega$$

As this is effectively connected in parallel with the $100K\Omega$ resistance in our above example, the equivalent resistance becomes $67K\Omega$. The potential divider thus becomes a combination of $100K\Omega + 67K\Omega$. The voltage across R2 thus becomes 1.8 instead of 2.25. The voltage being measured is really 1.8V as shown by the multimeter. The voltage across R2 changes due to the presence of multimeter and the measured value is falsified.

To get over this difficulty, the meter can be connected as shown in figure 3. The voltage across R2 is not measured directly, but compared with another voltage across the potentiometer P1. The difference in voltages will be shown by the multimeter, and will become zero when the two voltages are equal. The meter does not draw any current in this condition as voltages on both the terminals are equal.

The potentiometer can have a directly calibrated dial to read the voltage, or we can now measure the voltage

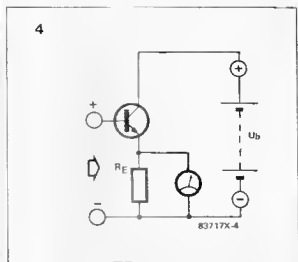
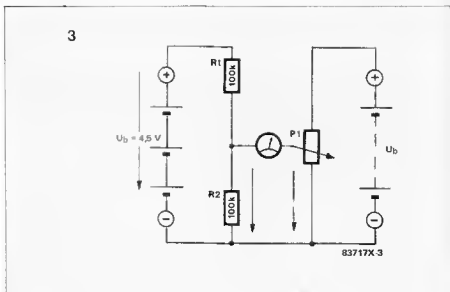

across the sliding contact of P1 independently. If the total value of P1 is $\times n$ low enough, the internal resistance of the multimeter will not affect the reading. Another way to get rid of this problem is to use a high impedance input circuit with the multimeter. The schematic diagram of such a circuit is shown in figure 4. The impedance converter contains an amplifier which requires a very low input current and gives a high output current which is proportional to the input

current. An emitter follower circuit can be used in case of ordinary transistors, and a source follower circuit can be used in case of FETs. The input voltage is not amplified by the amplifier and thus the measured voltage is indicated accurately by the multimeter without drawing input current from the voltage under test.

Effectively, the R_i of the multimeter can be said to have become very high. In case of an emitter follower, the theoretical value can be

Figure 3
No current can flow through the meter when voltages on both terminals become equal to each other. The meter indicates zero at this point. As the meter does not load the test circuit, the voltage values are not affected by internal resistance of the meter.

Figure 4

The high impedance attachment follows amplifier. The amplifier draws negligible current and does not load test circuit.

estimated as follows. The effective R_i is the product of the current amplification factor of the transistor and the parallel combination of R_e and R_i of the multimeter. As R_e is much smaller than R_i , we can have R_i (effective) = $RE \times$ Current Gain. Assuming that $RE = 4.7K\Omega$ and current gain = 250, the effective input impedance $R_i = 1.18M\Omega$. Thus the multimeter can now be said to have an input resistance of about $1M\Omega$ which is sufficiently high for most measuring applications.

Measuring Power With A Multimeter

The ability to convert a specific quantity of energy in a specific period into another form of energy is called power. Speaking in electrical terms we can say

$$p(t) = u(t) \cdot i(t)$$

where $p(t)$ is electrical power, $u(t)$ is voltage and $i(t)$ is current. In case of DC currents and voltages the relation becomes

$$P = U \cdot I$$

Capital letters are used for DC quantities which are not a function of time, that is, they do not change with time. Lower case letters are used for Alternating quantities, and to show their dependence on time they are written as $p(t)$, $u(t)$, $i(t)$ etc.

Let us first look at the DC quantities. Figure 1 shows U , I and P as steady levels (DC quantities). The current

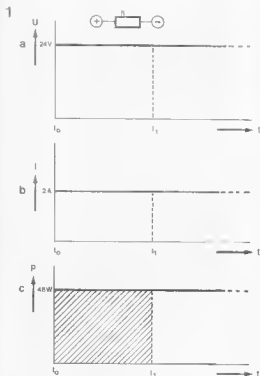

I flows through a resistance R and the voltage across that resistance is U . All these values do not change with time and hence at any given time the following relation holds good.

$$P = U \cdot I$$

Now for example let $U = 24V$, $I = 2A$ then we have the result as

$$P = 24V \times 2A = 48W$$

Here the W stands for Watts, which is the unit of the so called DC power. You must have noticed by now that measuring DC power with a multimeter is very simple! Just measure the voltage, then measure the current and then multiply them to get the DC power

Figure 1.

The values of DC voltage (a) and DC current (b) are constant at every instant. Hence the product (c) is also constant at every instant. The shaded area in (c) represents the energy which is converted into heat in the resistance R .

Now let us consider the other possibility. The voltage and current can be alternating values, as shown in figure 2.

We can come across such type of quantities in case of an output stage of an amplifier. The output stage produces an alternating voltage and current.

Can we use the multimeter to measure the power even in this case? Though the answer is Yes, it is not as simple as in case of the DC quantities.

Let us have another look at figure 2. Here an alternating current i flows through a resistance R and the voltage across the

resistance is U , which is also an alternating voltage. Naturally so, because the resistance has a fixed value of R ohms. The nature of waveforms for U and i are both sine waves. These are known as sinusoidal waveforms. They are variable with respect to time and said to be functions of time.

If we take the value of u and i at any given instant of time and multiply them together, we can get the power at that instant of time. This process can be carried out at every point on the time axis and the resulting power, which will also be a function of time, can be plotted as in

figure 2 C. The power can also be expressed as an average over a period T . For this purpose the average value converter can be used as shown in figure 3.

Using such converter, it is possible to obtain average voltage and current and then multiply them to get average power. However, this does not give the active power or the effective power. Also, please note that what we mean by average current and voltage is not the true average, because average current and voltage of a sinusoidal alternating waveform would be zero. The average we are talking about is after full wave rectification by the

bridge rectifier.

Why the active power or the effective power alone is a true measure for the power can be explained with help of the set up shown in figure 4. Here we see the output stage of a Hi-Fi amplifier connected to a loudspeaker and a headphone, along with a multimeter.

Now consider an alternating current flowing through the speech coil of the loudspeaker. Not only the membrane of the loudspeaker moves to and fro, the alternating current produces heat in the speech coil of the loudspeaker, because it also has an

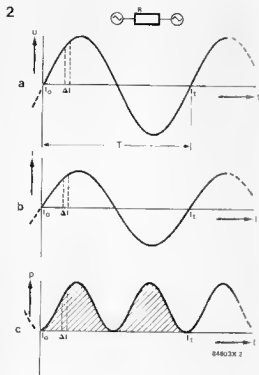

3

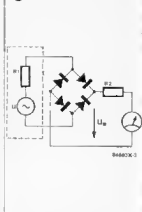
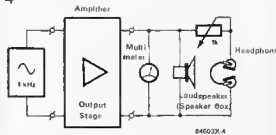

Figure 2
If a sinusoidal voltage (u) is applied to a resistance, then a sinusoidal current (i) is generated through the resistor. The power calculated at consecutive points can be plotted as in (c).

Figure 3
The average value converter consists of a full wave rectifier bridge connected to a moving coil meter. The moving coil meter effectively averages out the input voltage.

Figure 4
The measuring set up for measuring power with a multimeter. A practical set up is shown in the photograph in the beginning of this chapter.

4



5

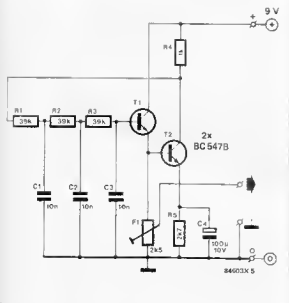

6

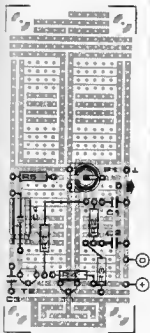

Figure 5
Sinusoidal signal generator for
1KHz.

Figure 6
Component layout of the circuit in
figure 5

Component List

- R1 to R3 39K Ω
- R4 - 1K Ω
- R5 2.7 K Ω
- P1 2.5K Ω Trim Pot
- C1 to C3 10 nF
- C4 100 μ F 10V
- T1, T2 BC547 B
- 1 Standard SELEX PCB
- 1.9 V Battery Peck

Ohmic resistance. The same quantity of heat could also be produced by a direct current. This particular value of direct current is called the effective current. The effective current is greater than the average value by 11%. For example, the mains supply voltage is 230V (effective value), where as the average value is only about 207V. If we connect the multimeter across the mains outlet, it reads 230V, because it is designed to read the effective value in the AC ranges. The scale of the multimeter is calibrated in such a manner that it directly reads the effective value for a sinusoidal alternating input. This is well suited for our requirement of power measurement.

The effective values of current and voltages are also called RMS values. Without going into the details, we can just note that RMS stands for Root-Mean-Square. This notation comes from the fact that for a sinusoidal alternating waveform the effective value is the square root of the mean of the squares. Using the effective (or RMS) values of voltages and currents, the same formula that is used for DC quantities becomes valid once again.

$$P = U \cdot I$$

This can be further simplified by using the Ohm's law

$$I = U/R$$

Thus the power equation becomes

$$P = U^2/R$$

From this relation, the power measurement becomes still more easier, because we need only one measurement - that of the voltage across the loudspeaker. Resistance (impedance) of the loudspeaker is specified on the loudspeaker as either 8 Ω , 4 Ω or 2 Ω .

All we have to do is measure the voltage square it and divide it by the loudspeaker impedance. For example, if we read 4.5V across the loudspeaker, and if the loudspeaker has 8 Ω impedance then the effective power is 2.53W. These measurements are carried out at a standard input frequency of 1KHz as can be seen from figure 4. The measurement however will depend on the amplifier setting.

What is of real interest is the non-distorted power output. To decide this, it is better to believe in one's own ears. A headphone can be connected as shown in figure 4, to check for exact setting of the amplifier volume control where distortion just sets in. The voltage can be measured at this setting and then from the loudspeaker impedance, the non-distorted power output can be calculated.

The 1KHz sinewave generator can be constructed as shown in figure 5 and 6. Component list is also provided for the circuit. For the same output voltage the effective power output depends on the loudspeaker impedance. This can be confirmed by setting the sinewave generator and the amplifier for an output voltage of 4.5V and then changing the loudspeakers from 8 Ω to 4 Ω and then to 2 Ω . The 8 Ω loudspeaker has about 2.5W, the 4 Ω loudspeaker has about 5W and 2 Ω loudspeaker has about 10W. If the amplifier is not rated for 10W output, distortion will set in with a 2 Ω loudspeaker.

Power Calculations

The most important formula used in power calculations is:

$$P = UI$$

which means that electrical power is the product of current and voltage. Another thing that becomes clear from this relation is that voltage or current alone is not sufficient to deliver any power output. A very common example of this is the crackling noise we sometimes hear while taking off a synthetic pullover. This noise is generated by the minute sparks generated by the static electricity. The voltages involved can be as high as 10KV. However these sparks do not harm us as the currents produced are negligible.

The power is measured in Watts, and a Watt is defined as follows:

$$1W = 1V \cdot 1A$$

If any two of the three quantities in the power equation are known, the third can be calculated.

Let us take an example. A bicycle dynamo produces up to 3W at 6V. So the current produced by the dynamo is:

$$I = P/U = 3/6 = 0.5A$$

Half an Ampere is not a very high current but it serves the purpose of lighting 3W bulbs at 6V! Here the voltage and current are both small and produce a small power output. However if we take the same current (0.5A) from our mains supply of 230V, the power output produced will be (230V) · (0.5A) = 115W

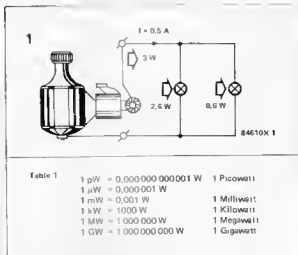

which is a substantial value. The difference is due to the higher voltage. From this we can clearly see that voltage and current both play an equally important role in producing power.

Let us consider a practical situation. A 100W bulb connected to mains supply of 230V. Its current can be calculated as:

$$I = P/U = 100/230 = 0.43A$$

And using the Ohm's law for calculating the resistance, we have:

$$R = \frac{230V}{0.43A} = 535 \Omega$$

This must be the resistance of the bulb. Surprisingly, a measurement of the bulb resistance with a multimeter gives a very low reading about 30 to 40Ω. What went wrong? our calculations, or the multimeter? Both of them are correct, and the

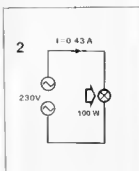

difference in two values can be explained by the fact that what we measured with a multimeter was the resistance of the cold element and what we calculated was the resistance of the hot element when bulb is glowing. When the bulb glows, there is a strong movement of electrons inside the glowing wire and the effective resistance increases. Unfortunately the mains voltage remains same even when the cold bulb is switched on across the mains supply. This gives rise to a very high initial current given by:

$$I = U/R = \frac{230V}{30\Omega} = 7.6A$$

This initial current flowing into the bulb lights the bulb and the element is instantly heated up. The resistance then increases to about 535Ω as seen before. The initial power drawn by the bulb is enormous:

$$P = (230V) (7.6A) = 1748 W = 1.75 KW$$

Figure 1. The bicycle dynamo produces 3W electrical power at 6V output. This gives a current output of 0.5A.

Figure 2. Although the 100W bulb requires less current than that produced by a bicycle dynamo, its power is much higher, because its mass supply voltage is much higher than the dynamo voltage.

Figure 3. When a 100W bulb is switched on it takes an instantaneous power of about 1.75 KW. For an old bulb this may prove to be fatal.

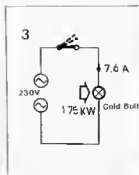

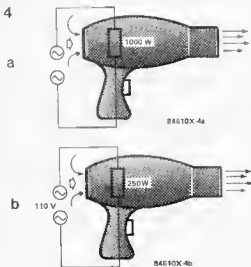

Fortunately, this power is just the initial instantaneous power and drops down immediately to 100 W as the bulb glows

Let us take another example to see how the supply voltage affects the power output to the same device Consider a 1000W Hair Dryer connected to 230V mains supply The current drawn is 4.3A

The consumption of the fan motor is negligible compared to that of the heater Now if we connect the same device to a supply voltage of 110V, will the power also reduce to about half the value? No, the power

drops to one fourth the original value As the voltage becomes half the current also becomes half and thus their product becomes one fourth The Hair Dryer now operates only at 250W

Let us now turn to some very low power devices. The antenna required by a radio is such a device The antenna intercepts the radio waves and produces a tiny voltage of about 10 μ V This voltage drives an equally tiny current through the antenna cable and the receiver If we assume the resistance to be of about 50 Ω , then the current is

5

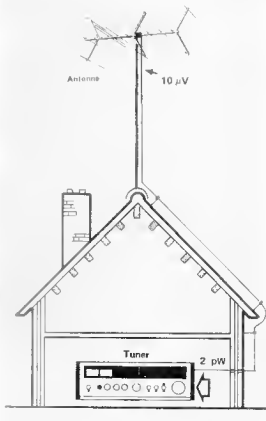

$\frac{10\mu V}{50\Omega} = 0.2 \mu A$
and the power delivered to the receiver is
 $(10\mu V) (0.2\mu A) = 2\text{pW}$
That is two picowatt or two billionth of a Watt !

Figure 4
A 1000 W Hair Dryer works only at 250 W when the input voltage becomes half

Figure 5
Although radio transmitters operate at very high power values, what reaches the reception antenna is just a few billionths of a Watt

The Digilex-PCB is now available!

Price:
Rs. 85.00 + Maharashtra Sales Tax.
Delivery charges extra: Rs. 6.00

Send full amount by DD/MO/PO.

Available from:

precious[®]

ELECTRONICS CORPORATION
Journal Division

11 Shamrao Vithal Marg (Kish Lane)

Off Laramington Road, Bombay-400 007.

NEW PRODUCTS

MICROCOMPUTER DEVELOPMENT SYSTEM

PROFESSIONAL-1 is a Microcomputer Development System, useful for developing completely the hardware and software of microprocessor based products.

Professional-1 helps the user in developing and debugging the target software in Assembly/high level language, using source programme stored in mini floppies. Target hardware can be debugged using the in-circuit emulator. Assembled programmes can be transferred on PROM programmer for programming the PROMS.



For more details, please contact

M/S PROFESSIONAL ELECTRONIC PRODUCTS
Opp. Old Detroi Post
Delhi Road
P B No 316 Meerut 250 002

GAS/SMOKE DETECTOR

Abhitron have developed a gas/smoke detector for protection against accumulation of gases like LPG, ethane, propene, carbon monoxide etc. Solid state in nature, this detector is compact in size, easy to install, reliable and shock proof.

Applicable in a large number of industries, it has an electronic buzzer with LED visual alarm. Consuming only 1.5W in 24 hours this system is available in wall and table mounting devices in 1/2, 4 channels. The instrument operates on both 230V AC and 12V DC.



For further information please contact

M/S ABHITRON INDIA
386 F/39 Mendodera Bldg
Near Badem Wadi, Lemington Road
Gurgaon, Bombay-400 004

μP BASED DATA LOGGER

ADVANI OERLIKON have developed a microprocessor based Data Logger for efficient control of process parameters in continuous process industries. It monitors and records data from various inputs and displays process information at a central place. The moment a set parameter is exceeded or a wrong trend sensed, the logger gives an audio-visual alarm.

Besides analog inputs, the Data logger can also process input from parallel 8CD, pulse input or contact status. The data logger features on-line programming, ease of reprogramming, compact size, reliability, speed of operation and low power consumption.



For more information, write quoting ref. No. P13/7/85 to
M/S ADVANI OERLIKON LTD
Post Box No 1546
Bombay-400 001

METAL OXIDE VARISTORS (MOV's)

Metal Oxide Varistors are transient voltage suppressors

and find extensive applications as protective devices. These devices are capable of suppressing high voltage spikes and surges appearing on AC/DC lines, to acceptable levels, thus protecting electronic components and systems from failures. MOV's are recommended for use in Thyristor Control Systems, SMPS, Voltage Stabilisers, PLCs, Electronic Timers, Computer Systems, Television and VCRs, HiFi Systems, Relay Contact Protection, motor protection and a wide range of other equipments. MOV's of internationally acceptable quality have been developed by Elpro International Ltd—an affiliate company of General Electric Co USA. Devices are now available locally in a wide range of operating voltages from 110V to 510V and for various energy ratings.

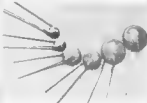

For further information write to
IG E (India) Ltd
"Nirmal", Nariman Point,
Bombay 400 021

AUTO RANGING DMM

MECO have introduced their Auto-ranging Digital Multimeter designated as **MECO 1210**. The above instrument has a 14-mm high 3 1/2 digit LCD, single range selector knob, with facilities for overload indication, low battery indication and unit announcement. It can measure DC Voltage upto 1000V, AC Voltage upto 750V, AC/DC Current right upto 10A, Resistance upto 20 Megohms, Diode test and Audible



continuity test. The instrument works on two 1.5V penlite cells with battery life in excess of 500 hours.

For detailed information, write to
MECO INSTRUMENTS PRIVATE LTD
Bharel Industrial Estate
T J Road, Swere
Bombay - 400015

HEAVY DUTY SOLDERING IRONS

M/s Component Technique represent American Electrical Heater Co for their range of Heavy duty soldering irons marketing under the name "AMERICAN BEAUTY".

FEATURES

Seamless Steel Casing. One piece, Round Lightweight Rugged.

Long Life Element, Nickel chrome on steel core. Compression wound, mica insulated. Every element tested at 1100 volts.

Plug type tip. Inserts deep into element for quick heat. Easily interchanged or replaced. Wide range of wattages and tip sizes.

Safety cord clamps. Cord can't pull out of handle. Greater safety for overhead work.

Rugged terminal assembly. Heavy duty brass connector bars.

3 Wire HPN cord, nema plug Standard.

Ventilated handle. Selected hardwood for insulating properties and durability. Rubberoid finished.

Modular construction. Easy maintenance.



For further details write to
COMPONENT TECHNIQUE
8 Orion Apartment
29 A Lalubhai Park Road
Andheri (West)
Bombay 400 058

Every Greaves Semiconductors' component is big on quality

Greaves Semiconductors, a subsidiary of Greaves Cotton, bears the family hallmark of excellence

Greaves Semiconductors has the largest installed capacity and the technology to offer you the widest range in semiconductor components. Whether you need a mere dozen power devices or a million diodes, you will get consistent high quality and the finest product your money can buy

In addition, the company is now poised for a significant breakthrough in indigenous technology

So the next time you need components, remember Greaves Semiconductors. It's a name that's poised to be a big force in the electronic industry in quality, firstly



The ideal import substitute



Greaves Semiconductors Ltd.

Industrial Development Area, Patancheru 502 319, Medak Dist., Andhra Pradesh
Tel : 208, 209 & 381 (STD Code 08453) • Telex 0152-222 GRSC

elektor INDIA Kits



LCD Thermometer Issue No. 26 EPS No. 82156

Simple! Easy to assemble. Based on IC 7106 This thermometer is very accurate with a temperature range - 50°C to + 150 °C. Ideal for house or laboratory.

Complete kit (with cabinet)
Rs. 575.00

Capacitance Meter Issue No. 11 EPS No. 811012 - 1/2

To measure those elusive farads, this project features

- Read out on a 3 1/2 digit LCD
- A measuring range from 0.1 pf to 20 mfd
- high accuracy.

It is a complete instrument of a hobbyists price Complete kit (without cabinet) Rs. 750.00

Digilex Digital Trainer

Teach yourself digital electronics in a simple, unique manner. Broaden your horizons and improve your fundamental understanding of the changing world of electronics around you. This trainer gives you an opportunity to learn electronics of a very reasonable cost.

Complete trainer of Rs. 325.00

Junior Computer Kit

This kit enables you to have a practical orientation of the concepts explained in the Junior Computer Book I. Get actual hands-on experience. Learn the basics of hardware and software in an innovative step-by-step manner.

And that too at an incredible low price!

Complete kit (without cabinet)
Rs. 1500.00

Elektor Binder — This reddish binder collects your loose copies of Elektor info in one handy volume. A

simple system enables you to add each copy as it arrives and to remove a single copy without disturbing the others.

Price Rs. 25.00 plus Rs. 5 for Packing & Postage

Kits currently available

Issue No.	EPS No.	Title	Price.
33	85110	Telephone Exchange	Rs. 1200.00
36	9827	Magnetiser	Rs. 65.00
37	80054	Talk Funny	Rs. 210.00
39	86013	Single Trace CRT Converter	Rs. 190.00
39	9967	VHF/VHF Modulator	Rs. 105.00
28/29	85447	Fault finding probe for Ups	Rs. 60.00
28/29	85431	Hi-fi headphone amplifier	Rs. 75.00
28/29	85476	Brakelight Monitor	Rs. 25.00
28/29	85448	Electronic Dog	Rs. 180.00

Buying one of our kits will save you the frustration of tracking down those elusive components that hold up your projects. General information

Ordering Information

1. All payments in Advance by M.O.R.O or D.D. only
2. Items will be sent by R.P. only.
3. Price includes Packing & Postage
4. For orders out of Maharashtra, India. Please add 1% as incidental Charges. Send payment to:

precious[®]
ELECTRONICS CORPORATION

Journal Division 11, Kith Lane, Off, Lamington Road, Bombay - 400 007.

8088 XT MAIN BOARD
8K EPROM EXPANDABLE
TO 40K EPROM
256K RAM ON BOARD
8 EXPANSION SLOTS
8088CPU WITH OPTIONAL 8087
CO-PROCESSOR

Looking for reliable consistent supplies to meet your marketing and production needs? Check us out! Our quality is consistently high, prices are competitive, and deliveries are quick and prompt. We'd like to tell you more about ourselves, so why not contact us today? Big and small orders are welcome!

**COMPUTER PARTS,
 COMPONENTS AND C.K.D.
 AND S.K.O. TO MEET YOUR NEED**

FLOPPY
DISK DRIVE CARD
CONTROL FOUR DS DD
DISK DRIVES
EASY TO INSTALL

COLOR
GRAPHICS CARD
USED FOR COLOR,
MONOCHROME
R G B AND B/W MONITOR
WITH VIDEO RCA AND
R G B OUTPUT



Our Product Range:

- PCB Connectors (2.5mm mini size, 2.54mm, 3.96mm)
- Terminals For Connector Use (M & F)
- Flat Cable (2-64 pins)
- D-Sub Connectors and Hoods (9, 15, 25, 37 pins)
- 57 Series Connector (M & F)

- IDC Socket/Plug Connectors (16, 20, 26, 34, 40, 50 pins)
- IDC Card Edge Connectors (20, 26, 34, 40, 50 pins)
- 57 Micriban IDC Connectors (M & F)
- 25 Pin Micriban IDC Connectors (M & F)
- Cable Assembly

For fully detailed information send your inquiry today!



立偉電子私營有限公司
Device Electronics Pte. Ltd.

Town Office 101 Kitchener Road #02-04 Jalan Besar Plaza Singapore 0600 Tel: 2986455 (6 Lines)
 Fax: 2926627 Telex: DEVICE RS 33250 Cabre DEVITRDNC
 Factory 605B MacPherson Road #04-12 Connaught Industrial Complex
 Singapore 1335 Tel: 2866455 (6 Lines)

classified ads.

Hurry Wonder Musical Bell (UM 3481, 82/83/84) Twelve Melodious Songs in memory plays next Song every time Complete kit yours for just Rs 80.00 Send 50% with order (M O/D D) To INTELLIGENT ELECTRONICS 65 SBI Colony, Gopal Nagar NAGPUR 440022

Attention Hobbyists We supply quality imported electronic components like ICs — All type Capacitors Rubycon, Radial 2200 uF 50V Rs 25 - 3300 uF 50V Rs 30 Diodes in 5408 Rs 3 50 1N 4003 etc. and many other difficult to obtain components. Hardware many more. Send enquiry with SAE for terms stock to Malini Vagle 51 Vishwak Arak Apts Bandra (East) Bombay 400 051 Tel 6402793 6407901

advertisers index

ADVANI OERLIKON	11 04
APEX ELECTRONICS	11 70
ATRON	11 64
CREATIVE DATA SYSTEMS	11 09
CTR	11 69
CYCLO COMPUTERS'	11 66
COMTECH	11,14
COSMIC	11 76
DEVICE ELECTRONICS	11 67
DISCO WINDING WORKS	11 10
ECONOMY ENGINEERING	11 70
ELECTRONICA	11 72
ELTEK BOOKS	11 10
ENGINEERING SYSTEMS	11 15
GREAVES	
SEMICONDUCTORS	11,63
IEAP	11,08
J M ENTERPRISES	11 71
KLAS ENGINEERING	11 74
KUSUM SALES	11,72
LEADER ELECTRONICS	11 12
LEONICS	11,10
MECO INSTRUMENTS	11 73
MELTRON	11 13
NCS ELECTRONICS	11 70
PECTRON	11 70
PIONEER ELECTRONICS	11 64
PRECIOUS	11 65
PHILIPS	11,07
SAINI ELECTRONICS	11 68
SCIENTIFIC	11,64
SONODYNE	11 02
S M J ELECTRONICS	11 11
SS INDUSTRIES	11 12
SUPERB	11.14 11 68
SWASTIK	11,05
THERMAX	11 66
TRIMURTI	11 08
TESTICA	11 72
TEXONIC	11 66
VALIANT	11 73
VASAVI	11 14
VISHA	11 75

CORRECTIONS

In various car theft alarms published in *Elektronika* over the past year, the alarm had the facility of incapacitating the ignition system when the alarm is set. It has been found that this can lead to damage to electronic ignition systems, and in cars fitted with such a system, it is therefore better to use the relay that incapacitates the ignition system to break the supply to the starter motor (relay)

VHF Preamplifier

(May 1986 p 32)

The value of capacitor C₆ should be 1n

Car burglar alarm

(Aug 1 Sept p 57)

As drawn, the voltage across relay

RE₁ cannot drop to zero, it is, therefore, better to connect the emitter of T₁ to the +8 V line via an 18k resistor instead of to the collector of T₂.

Indoor unit for satellite TV reception — 1

(In This Issue)

1. Owing to a processing error at the printer's the lines between C₆ and MX pin 1, and that between R₅ and the collector of T₂, have shorted, yet incorrect gaps. As the T₂ base resistor is badly blurred, this is R₄, 10 k

2. In the component overlay, Fig. 6, the resistor identified R₂ in the LO section should be R₂₀

3. Please add to Fig 5d C — isolating bush

Impact Extruded Capacitor Housings

from

KLAS

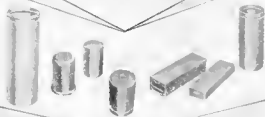

- * Automated mass production ensures low unit cost and quick delivery
- * Special rectangular & oval cans with grooves and other projections
- * 99.5% pure Aluminium. Close tolerances can be maintained
- * Wide range of sizes 5 to 90 mm dia, upto 250 mm length



Klas Engineering Private Ltd.,

31, 1st Block East, Jayanagar, Bangalore 560 011
Phone 604653 Gans. KLASCAN Telex 0845-756 KLAS IN

BAC/VAL-8A



WE WISH YOU
A HAPPY DIWALI &
NEW YEAR



RUSH YOUR ORDER TILL STOCKS LAST!

'LED DIGITAL CLOCK KITS'

Using
IC MM 5387

With AM/PM Indication,
Flashing colors, Alarm,
Snooze & 59 Minute Sleep
Timer & Having Battery
Back Facility

Using
IC MM 7317

With AM/PM Indication
Flashing Color, Alarm,
Snooze & 57 Mints
Sleep Timer, Battery
Back-up & Calendar Function

Using
IC MM 5402

With AM/PM
Indication
Flashing Color,
Alarm, Snooze
& 59 Mints Sleep Timer

**DEMANDED
KIT**

NiCad Cell
Charger kit
Semi assembled
Music door bell
With speaker

**NOW
AVAILABLE**

Stereo Graphic Equaliser
10 bands per channel
Complete kit
With cabinet

**SPECIAL
OFFER**

LDR small
LDR medium
LDR big

**NEW
ARRIVAL**

Solderless Bread board
Small size
(WBU-301)
Medium size
(WBU-102)

EX STOCK

TELEPHONE EXCHANGE KIT
LCD THERMOMETER KIT (WITH CABINET)
LCD 3 1/2 DIGIT DIGITAL PANEL METER KIT
VHF/UHF TV MODULAR KIT

THE LARGEST KIT SELLER IN INDIA

VISHA
ELECTRONICS

TERMS :

- Goods by return subject to availability
- Special prices for Volume orders
- Minimum outstation orders Rs 50
- All prices are exclusive of M S T

- All orders must carry a minimum advance payment through VPP (cheque payment)
- Price are subject to change without notice will be charged as per date of despatch of goods
- Price of 50% (No any prior)

17, Kalpa Building First Floor 349, Lamington Road Bombay - 400 007 Tele 362650.

Black magic



Nakamichi AX-1000

**Featuring SMPS,
a unique advance
in audio technology,
coming to India
for the first time.**

Vibrating with 250 watts of peak energy, breaking all sound barriers, touching rare heights, here

comes, at last, an Amp/Deck marvel which will fill your senses as never before.

This classic black model — Nakamichi AX-1000 with its unique Switch Mode Power Supply (S.M.P.S.) has music surging through its sophisticated circuitry, with such sonic purity and clarity, that one hears not the reproduction of music, but the actual recreation of it.

Backed by the audio expertise of Cosmic, this latest generation model, has a dynamic one touch recording system, a super hard perm alloy head, soft touch controls, L.E.D. peak level indicators, double gap erase head plus much much more for over all excellent performance. This powerful Amp/Deck has arrived, to cast a spell, even on the perfectionists. So get ready for some hypnotism.

**Cosmic
Nakamichi
AX-1000**

It's pure black magic

Price Rs. 4,500/- all inclusive
(only for Bombay city)

COSMIC
We are sound