

130

March
1986

elektor

INDIA

Rs 7.50

electronics



**Electronically
controlled cameras**

R F circuit design

Active aerial with SMDs

Artificial intelligence

Satellite TV receiving equipment



Sum of days

electronics technology

Electronically controlled cameras 3-17
 a close look at the innards of a Minolta 9000

Satellite TV receiving equipment 3-25
 offering an alternative to BBC and ITV programmes

The future for artificial intelligence 3-35
 how will fifth generation computers affect our daily life?

The accordion image sensor 3-37
 Philips scientists are developing a new type of solid-state image sensor

Designing a closed loudspeaker box 3-46
 a simplified approach to hi-fi quality sound reproduction

projects

DC operated battery charger 3-22
 how to charge NiCd batteries from a car battery

Active aerial with SMDs 3-28
 a simple but useful introduction to working with surface mount devices

MSX extensions 3-30
 the second article in the present series describes an add on cartridge board

Graphics card 3-39
 the concluding article deals with the colour extension board

RF circuit design 3-48
 this first of a short series of articles looks at making a test oscillator

information

News and views 3-15

New products 3-59

Readers Services 3-64

guide lines

Switchboard 3-65

Classified ads 3-74

Index of advertisers 3-74

selex-10

Digi-course II (Chapter 4) 3-51

Variable power supply 3-53

Attachment for multimeters 3-56

FAST AUTOFOCUS BY MICROPROCESSOR

Our cover this month shows the Minolta 9000 with in front of it the electronic circuits by which it is controlled. Perhaps the outstanding feature is the electronic control of the focusing system, which is fast and accurate: a real aid to rapid photography. The next step in the development of cameras is replacing the film by a miniature floppy disc.



AT LAST



THE PRECISION AND QUALITY
you were looking for at realistic prices

YABASU

PCB Drafting Aids now made in India.

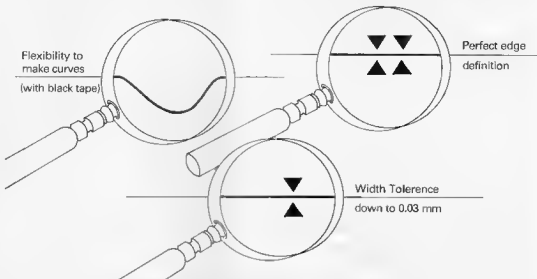

- Tapes in black, red & blue. All widths in inch or metric measure available ex-stock.
- IC Patterns and Donuts to be introduced soon.

Write to

PRECIOUS ELECTRONICS CORPORATION

52-C, Chhotani Building Proctor Road, Grant Road (E), Bombay-400 007.

Dealers wanted all over India



Publisher: C R Chandarene

Editor: Surendra Iyer

Editorial Assistance: Ashok Dongra

Advtg & Admn: J Dhas

Production: C N Mithagan

Address

ELEKTOR ELECTRONICS PVT LTD
52 C Proctor Road,
Bombay - 400007, India

Overseas editions

Glenio Publishers Limited
Standish House Bath Place
High Street Barnet
London EN5 1EO
Editor: Ian Seymour

Elektron BV
Peter Teckpoolstraat 2 4
6191 VK Beek the Netherlands
Editor: P E L Kersemakers

Elektron satl
Route Nationale, Le Seau B P 53
58270 Bailleul France
Editors: D R S Mevel, G C P Raerleider

Elektron Verlag GmbH
5133 Gangolf Postfach 1150
West Germany
Editor: E J A Krenschauer

Elektron EPE
Karadakki 14
16573 Voula Athens Greece
Editor: E Xanthoulis

Elektron JCE
Via Rocellina 12
20124 Milano Italy
Editor: D Fumagalli
Ferrera & Bento Lda
R D Estrelina, 32 1^a
1000 Lisboa Portugal
Editor: Jorge Goncalves

Ingolek S A
Av Alfonso XIII, 141
Madrid 16 Spain
Editor: A M Ferrer

**International co ordinating
& technical manager:** K S M Waliawan

The Circuits are for domestic use only. The submission of designs of articles in *Elektron* implies permission to the publishers to store and transmit the text and design and to use the contents in other *Elektron* publications and activities. The publishers cannot guarantee to return any material submitted to them. All drawings photographs printed circuit boards and articles published in *Elektron* India are copyright and may not be reproduced or stored in whole or part without prior written permission of the publishers.

Patent protection may exist in respect of certain devices components etc. described in this magazine.

The publishers do not accept responsibility for listing or identifying such patents or other protection.

Distributors

Blazez Publishers & Distributors Pvt Ltd

Printed At
Tripathi Offset
Bombay 400 013

Copyright © 1986 Elektor B V
The Netherlands

Towards a common open network standard?

More and more users — and prospective users — of communicating machines, irrespective of whether these are robots, computers, telephones, or a mixture of them, are envisaging networks that comprise machines of different makes. There is a common belief that when this becomes possible, markets will expand more freely, because competitive power will then not be dependent on which particular manufacturer a dealer is tied to, but rather on the price, function, and performance of the machines. Most users are, understandably, in favour of a completely open network, i.e., one that will allow any make of equipment contained in it to freely exchange information with any other make of terminal attached to it.

There is a snag, however, or, rather, there may be. The successful interlinking of different makes of communicating machines requires an internationally accepted standard. The International Standards Organization — ISO — is developing a general data-communications standard called Open Standards Interconnections — OSI — which, it is hoped, will eventually facilitate the linking of, for instance, computers from different manufacturers. However, and here is the possible snag, IBM, which dominates the world market for mainframe computers (IBM and IBM-compatible computers account for over 80 per cent of the world market), has its own system for connecting in computers, called Systems Network Architecture, SNA. Some 20 000 SNA networks are already fully operational.

Competitors of IBM, fearing that the SNA standard may further increase IBM's share of the market (and thereby reduce theirs) are already cock-a-hoop with OSI, although this will not be fully defined for quite some time yet.

Although IBM, like other industrial giants, is used to proprietary standards, which can be made to force users into buying only their products, it is carrying out research and development on OSI. In fact, last October it brought out a local area network — LAN — that is fully open to other makes of equipment. Moreover, spokesmen for IBM have on several occasions recently reiterated IBM's backing of OSI. Cited is, for example, the value-added network — VAN — that IBM will operate with Japan's NTT, and which will have to accommodate NTT's open standard as well as SNA.

At present, these developments look encouraging, and, sceptical though we may be, we must hope that the basis of a common interlinking standard will be agreed soon.

COMING SOON IN
AN INDIAN EDITION

THE

BOOK

A
comprehensive
& exhaustive
document for
amateurs and
professionals.

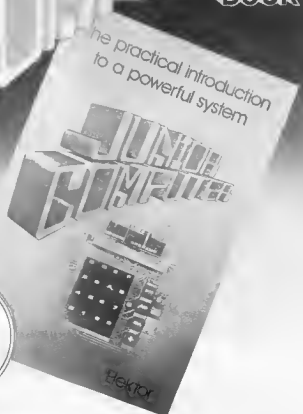

Now You Can Learn All That You Want To Know About Computers Operation - Programming Hardware - Software

The cost and complexity of home Computers is a serious deterrent to the newcomer to computer operating and programming. We know of many people who would like to build their own but who lack necessary technical knowledge. The Junior Computer has been designed (for just this reason) as an attempt to 'open the door' to those readers who need a push in the right direction. It should be emphasised that, although simple to

construct, the Junior Computer is not a 'toy' but a fully workable computer system with the capacity of future expansion. It has been designed for use by amateurs or experts.

Published by
ELEKTOR ELECTRONICS PVT. LTD.,
52 - C Proctor Road, Bombay - 400 007
Phone : 36 74 59 / 36 94 78

TIME TESTED ELECTRONIC TIMER

A new concept In Electronic Time Delay is introduced. Our up-to-date and innovative technology gives trouble free service and long operational life.

ADVANTAGES :

1. High repeat accuracy $\pm 1\%$.
2. DPDT relay with contact rating of 10A.
3. Two mode of operation-delay on energize/interval.
4. Fifteen voltage ranges from 12 V AC/DC to 240 V AC.
5. Three types of terminations.
6. Available upto 60 hrs. Time range.
7. More than 4000 types to choose.



For further details contact :
KOENIG ELECTRONICS & INDUSTRIES (P) LTD.
 54, INDUSTRIAL AREA, PHASE-II,
 CHANDIGARH-160 002.

**Ace MFRs
 Now LCSO approved**

**Ace sputtered
 METAL FILM RESISTORS**
 First in India
 Approved by LCSO with Latest
 Sputtering Technology from Varian, USA.

- Ace MFRs LCSO approved to RFGP-2 (1/4 W), 100 PPM, $\pm 1\%$ tol 47 Ohms to 330 K. Available range is 1/4 W, 15 PPM to 200 PPM, 0.1% to 5% tol, 10 E to 1M values
- Ace CFRs LCSO approved to RFGP-3 (1/4 W), $\pm 5\%$ tol Available range is 1E to 30 M.



FOR DETAILS, CONTACT

**Ace Components
 & Electronics Pvt. Ltd.**

PLOT No. 11 & 12 HOUSTAGALLY INDUSTRIAL AREA ANANDRAI 571 188
 CABLE ACECOMP TEL. 21910 BANGALORE OFFICE PH. 41833

Representatives/Distributors

- BANGALORE AAREX AGENCIES Ph. 27871
- BOMBAY. I.I. DESAI ELEC Ph. 829140
- CHENNAI ELECTRONIC EQUIPMENTS CORP. Ph. 385885
- DELHI I.I. S.S. GOEL Ph. 587042
- HYDRABAD ARADHANA ELECTRONICS Ph. 234360
- LUCKNOW VIJAY NAGRAJE Ph. 47324
- MADRAS (1) PAI ASSOCIATES Ph. 811320
- MUMBAI MODE ELECTRONICS Ph. 21356
- PUNE SAKURUSHI ENTERPRISES Ph. 418040
- SECUNDERABAD ARADHANA ELECTRONICS Ph. 822201
- TRIVANDRUM ACE INDIA Ph. 70316

Ace - More Functional Reliability at no extra cost



Inductive Solid State



PROXIMITY SWITCHES

For Fast, Error-free operation.



- Solid state Contactless Limit Switches with no mechanical moving parts - free from common defects of mechanical limit or micro switches such as roller breakage back lash contact bounce, etc.
- AC & DC versions, with sensing ranges from 5 to 20 mm
- Wide applications in Textile Machinery Machine Tools Cement Plants Lifts Conveyor Systems and as Speed controllers.

Indian Engineering Company

Katara Mansion, Post Box 16551, Worli Naka, Bombay-400 018.
 Ph. 493-9644/45, 493-5565 Telex: 11-75217 Grams: AMPVOLT.

Modipon

ADVANI-OERLIKON BRINGS YOU ADOR PC-4896

India's first cost-effective programmable logic controller.

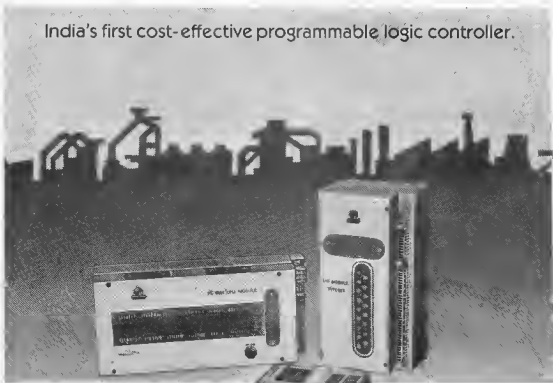

Trust Advani-Oerlikon research to design and develop India's first cost-effective programmable logic controller. Based on a microcomputer chip, ADOR PC-4896 can accept as many as 96 I/Os. Thus making it ideal for use in continuous process plants where several functions are involved: logic control, sequencing, timing, counting, etc. ADOR PC-4896 has an edge over conventional relay panels. Simple to

programme and easy to operate, it obviates the need for trained personnel, programmers and software specialists.

while eliminating cumbersome relay/contactor hardwired systems which have to be planned and designed much in advance of a project.

ADOR PC-4896 incorporates the latest microprocessor-based design leading to low power consumption. Modular in construction and compact in size, it offers the same flexibility of computers — without the high cost.

APPLICATIONS

Cement Plants

- Control of synchronized drive in sequence for crushing section
- Control and interlock of raw mill kiln section, coal grinding, coal fly-ash handling

Steel Plants

- Cold rolling mills
- Blast furnace firing sequence control

Petrochemical Plants

- Start-up sequence of huge crude handling systems
- Pipeline controls

Thermal Power Plants

- Logic circuit causing main unit shutdown
- Boilers and turbines start up and shutdown process

Paper & Pulp Industries

- Automatic mixing and dispensing of ingredients
- Material Handling
- Control of powerfree conveyor systems

ADOR PC-4896.

The logic behind continuous process controls.

For enquiries, quote Key No. AO-531 and write to P.B. No. 1546, Bombay 400 021



ADVANI-OERLIKON LIMITED

Regd. Office: Baroda | Bhavnagar | Bikaner | Calcutta | Coimbatore | Delhi | Hyderabad | Jaipur | Kanpur | Lucknow | Madras | Patna | Pune | Raipur | Thiruvananthapuram

Circle AO-531

Device offers



**ELECTRONIC
EDUCATIONAL
& TESTING
DEVICES**



Solderless Bread Board



1 OL-400 Logic Trainer

1 OL-800 Digital Lab



1 OL-500 Analog Lab

DT-01 Digital Trainer

We stock:

elektor
Magazines

KC IZUMIYA I.C. INC.
P.C.B. Drafting Aids

TELEDYNE
RELAYS

RCA
Semiconductors

**KONTAKT
CHEMIE**
Cleaners

RAYTHEON
Semiconductors

FAIRCHILD
Semiconductors

TEXAS INSTRUMENTS
Semiconductors

VRN Trimming
Potentiometers

Ribbon Cable
Connector Panels

SSS
Semiconductors

RS 232
Connector Panels

SPECIAL EX STOCK OFFER

E-Prom

D-RAM	Regulators	SCR/Triacs	TTL/CMOS	2716	27128
4116	41256	7805 - 24	4 amp - 40 amp	74 LS00 - 629	2732
4164	42128	7905 - 24	400 V - 600 V	4001 - 40257	2764

Bulk importers and users in India may kindly forward their specific enquiries



Device Electronics Pte. Ltd.

101 Kitchener Road *02-04, Singapore Electrical, Electronics and Hardware Centre,
Singapore 0820 Telex : DEVICE RS 33250

FOR ENQUIRIES **CALL: 298 6455** (4 lines)

electronically controlled cameras

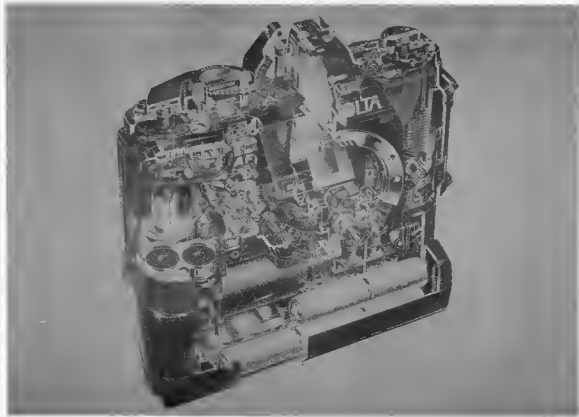

Ever smaller chips with ever larger capacities form an ideal partnership with the modern camera. We thought it would interest a great many readers to find out how the two fit together, and based this article on the Minolta 9000.

When Daguerre laid the foundations of photography in 1839, he also started the development of the photographic camera. For more than a hundred years, the camera remained a purely mechanical device. From a cumbersome square box with a fixed lens, it slowly turned into a small and handy piece of precision engineering, that offered more and more facilities. It is only relatively recently

that electronics began to be used in cameras. True, the exposure meter of thirty, forty years ago used a selenium cell and a very sensitive moving coil meter. For many years this type of exposure meter was the only photographic aid that used electronics. Later there followed the CdS exposure meter, and by this time it had become small enough to be built into the camera. But true elec-

tronic components were then—some twenty years ago—still too large to be fitted inside a camera. It was only when the transistor became miniaturized and integrated circuits (chips) made their appearance about fifteen years ago that camera manufacturers began to see the advantages of complementing the conventional mechanical parts in a camera with electronic devices. And

soon electronics proved to be not only cheaper in production, but also capable of giving more accurate and better reproducible results. Reliability remained a weak point for a time, but not for long. The results were semi-automatic cameras, electronically controlled shutters; programmable automatics; and others. These developments gave rise to the modern camera in which virtually

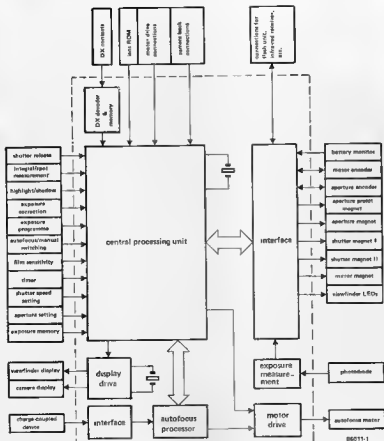

Fig. 1. Block schematic of a typical electronically controlled camera here, the Minolta 9000. All control is vested in two microprocessors.

Fig. 2. Construction of the photocell. The whole area of the cell is used for integral measurements, but only the annular part at its centre for spot measurements.

everything is controlled by electronics. Even focusing is now accomplished with the aid of a small motor, so that the photographer can concentrate wholly on the subject and composition. Such a camera is, of course, an ingenious piece of engineering as may be gathered from the photograph on p. 19.

What facilities?

After first looking at the facilities of the Minolta 9000, we will describe how all these are realized by electronics.

■ Automatic focusing system: when the shutter release is half depressed, the subject is automatically put in focus. A

memory makes it possible to focus first and choose the subject afterwards.

■ Electronically controlled shutter with exposure times of 1/4000 to 30 s.

■ Exposure meter with a choice between integral and spot measurement. With spot measurement it is furthermore possible to measure the lightest and darkest part of the subject separately. Again, a memory is provided for storing the measured values.

■ Exposure modes. (a) manual; (b) aperture priority auto exposure; (c) shutter priority auto exposure; (d) programmable — in this mode the camera itself selects

the f-number and the shutter speed.

■ Through-the-lens flash measurement, enabling the use of all types of exposure automatics. Red LEDs in the flash unit are activated automatically when the ambient light is insufficient to allow the camera to be focused.

■ Advanced peripheral equipment, such as a flash unit with zoom reflector that automatically sets itself to the focal point of the lens in use; motor drive with 5 pictures per second and autofocus priority; databack with multi-spot metering facility, interval timing, and a facility for making individual exposure pro-

grammes; and a separate exposure meter that can wireless convey the metered information back to the camera.

On top of these there are some other noteworthy facilities. It is, for instance, no longer possible to set the f-number and shutter speed manually the whole range of f-numbers and shutter speeds must be scanned with the aid of small slide switches until the correct values have been arrived at. Film sensitivity is set with a push-button — it can also be done by the film itself with the aid of the DX code printed on it. It takes some time, therefore, before you are used to this camera, because the usual rotary

mechanical switches are conspicuous by their absence.

The central processing system

The monitoring and control of all these facilities require no fewer than 150 000 transistors in the shape of two microprocessors and some smaller ICs. The block diagram in Fig 1 shows what is controlled by the two microprocessors. The central processor serves all general facilities, while the second deals exclusively with the autolocus. All other blocks within the dashed lines are separate ICs. Outside the dashed lines are the operating switches and push-buttons; the control devices, such as the magnetic switches and the autolocus motor; the displays; a charge-coupled device—CCD; encoders; and the various connections between the electronics and the peripheral units.

The central processing unit (CPU) receives a great number of inputs from various sources.

A pair of contacts in the camera lead information as to the sensitivity of the film used to an integrated circuit that decodes and memorizes the information in digital form. The film carries a so-called DX code for this purpose. The memory of the IC can be read at any moment by the CPU.

Each autolocus lens contains a read-only memory (ROM) in which the principal data of the lens are stored: smallest and largest aperture, and focal length. These 8-bit data are read by the CPU thirty times per second. This has been so arranged because, when a zoom lens is used, the focal length changes every time the zoom is adjusted. Slide contacts in the lens enable the code for the focal length to be con-



stantly matched with the actual value. In this way, the CPU is fed with up-to-date lens information at all times. In a zoom lens, the ROM also arranges the conversion of the slide contact positions into a serial data stream.

The CPU also needs the information as to focal length for the autolocus processor and for the reflector position of a flash unit.

The connections to the motor drive and the camera back primarily use serial data streams also.

The CPU is connected via an interface to all parts that switch, monitor, or sense anything in the camera; to peripheral units such as a flash gun or an infra-red receiver; and to the exposure meter. The exposure meter consists of an integrated circuit that evaluates the amount of incoming light with the aid of a photo-

diode at the bottom of the mirror compartment and converts this analogue value into binary digits (=bits) that are led to the CPU. The photodiode is a very fast type, because it not only serves to sense the amount of ambient light, but also that of flash light. The information as to flash light is, however, used in analogue form, because digitizing and processing it would take too long. Electronic flash units provide flashes of between 1/1000 and 1/50000 second. The photodiode measures the amount of flash light that falls onto the film, and as soon as this reaches the required value, it signals to the flash unit to stop the flash immediately. This clearly illustrates the necessity for a very fast photodiode.

The Minolta 9000 uses a very practical method of (electrically) switching between integral and spot measurement — see Fig. 2.

This photograph shows the multitude of electronic devices it is almost unimaginable that all this—and the many optical and mechanical parts—fits into such a small case

The photocell has the same length-to-width ratio as the window. In integral measurements the total amount of light falling onto the cell is measured, whereas in spot measurements only the light falling onto the cell through the annular conductor is taken into account.

The encoders connected to the interface IC consist of tiny cog-wheels and opto-couplers. One of the cog-wheels is connected to the autolocus motor and the other to the f-number control. In this way, the CPU obtains information as to the angle of rotation of the autolocus drive motor and the f-number setting.

The magnetic aperture switches ensure that the shutter is released at the right moment.

The two magnetic shutter switches operate the first and second section of the metal shutter respectively;

Fig 3 The autofocus system 3a shows how the beam of light travels from the object to the CCD, 3b shows how two identical images are projected onto the CCD element with the aid of two lenses, the distance between the two images and their location on the CCD give an indication of the state of focus of the object (3c)

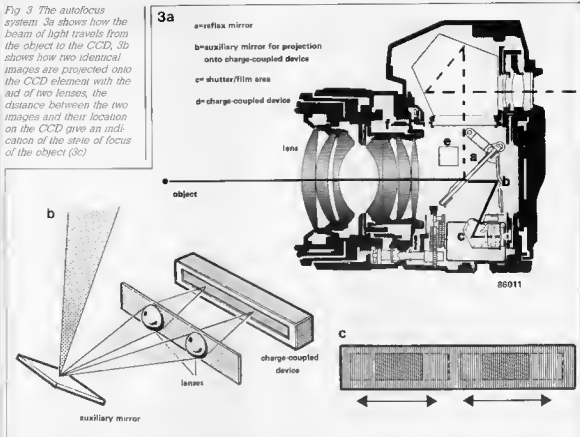

the interval between the two operations is determined by the CPU.

The operating controls of the camera are shown at the left-hand side of the block diagram. In reality, each of these is a simple push-button or slide switch.

The two liquid-crystal displays (LCDs), one in the viewfinder and one at the top of the body of the camera, are controlled by a separate IC. The displays give information as to shutter speed, f-number, the selected exposure programme, the method of measuring the exposure time, and any corrections.

The exchange of information between the CPU and the autofocus processor will be described later in this article.

If it is clear from the description so far that the CPU is the brain of the camera that constantly receives, processes, and transmits data for the operation

and control of the various parts of the camera. To this end, it contains 3 Kbyte of software (mask programmed ROM), and some 100 bytes of random-access memory (RAM) for temporary storage of data. A noteworthy aspect is the clock frequency which, at 4.2 MHz, is higher than customarily found in CMOS processors.

The autofocus system

The autofocus system consists of a microprocessor IC, a charge-coupled device (CCD), and a small but powerful motor. The processor, which has a 3 Kbyte programme, receives information from the CCD via an interface and on that basis, and in conjunction with the CPU, drives the motor via a separate driver IC. The CCD is an image sensor containing 128

sequential image dots. A tiny part at the centre of the field of view is projected twice via two small lenses onto the series of dots, as illustrated in Fig. 3a. The image sensor is located at the bottom of the camera and obtains its information from an auxiliary mirror that is situated behind the main mirror and immediately in front of the shutter. This process is shown in slightly different form in Fig. 3b. The double projection onto the series of dots is shown in Fig. 3c. If the object is sharply focused, each image occupies a certain number of dots at a certain location on the CCD. All dots are continuously scanned by the interface IC, which converts the measured analogue value of incident light into binary data. This information allows the autofocus processor to determine the exact location of the two images on the CCD. When the ob-

ject is not in focus, the two images will be further apart or closer together. The autofocus processor calculates the distance between the two images and from the result it can determine into which direction the lens must be turned to obtain a sharp focus. The perfection with which this happens is illustrated by the fact that the drive motor is slowed down when the object is almost in correct focus, and shored out immediately if it is in sharp focus. The motor position is then immediately stored in the CPU. We know from our own experiences that this system works fast and reliably. The only drawback is that if the tiny part of the field of view is evenly coloured and lighted, this results in insufficient information for the autofocus processor to function correctly. But in such a situation it is quite easy to point the camera at a somewhat more con-

Fig 4 Another schematic representation of the interplay of the mechanical and electronic parts in the autofocus system

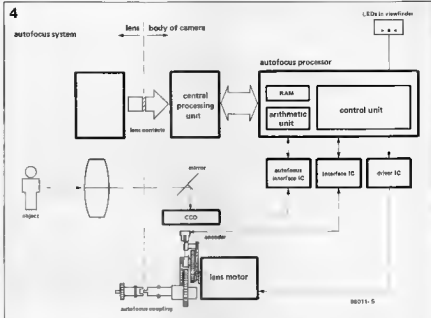

fracting part of the object, memorize this information by half depressing the shutter release and then pointing the camera to the wanted part of the object again. Conversely, the autofocus system may be switched off, and the focus set manually.

An interesting feature of the autofocus system is that if the ambient light has a value of less than 3 (with 100 ISO film), some red light-emitting diodes (LEDs) with reflector in the associated flash unit are switched on by the camera for a few seconds. These LEDs project a tiny red spot at the centre of the viewfinder image, i.e. from where the CCD gets its information. The spot contains a grid that provides an artificial contrast, so that the camera can be focused in complete darkness.

Exposure modes

The Minolta 9000 has four exposure modes. (a) manual, (b) shutter priority automatic exposure; (c) aperture priority automatic exposure; (d) programmable. When the programmable

mode is selected, the camera sets the shutter speed and stop value, for which there are three different programmes: one for lenses with a focal length below 35 mm; another for 35 mm to 105 mm lenses, and the third for telephoto lenses. The longer the focal length of a lens, the more stress is laid by the programme on selecting the fastest possible shutter speed to cut out telephoto blur from camera shake. The camera itself chooses the right programme based on the focal length information it has received from the lens ROM. When a zoom lens is used, the camera may even change between programmes, if necessary, when the zoom is altered.

Exposure modes have already been discussed, but there are two extra facilities. In positions H (high light) and S (shadow) the lightest and the darkest part of the image respectively may be measured, after which a correction is introduced which ensures that the measured parts will, indeed, be shot as white and black respectively. The correction is matched to the contrast range of modern films and amounts to +2.3 stop

at H and -2.7 stop at S. If the optional Programmable Camera Back is fitted, the user can make his own programme curves for the exposure automatics, or to carry out multiple spot measurements, from which the camera calculates the average value.

Electronics everywhere

Wherever you look in the camera you see flexible PCBs. Miniaturization is the key word in the camera industry, and the use of surface-mount devices is already well established. Real switches and push-buttons are no longer found: in the place where you would expect these, you will now find a miniature slide or press device. These cameras are very robust. The electronic components are all custom made. The micro-processor ICs, the displays, the metering ICs, and the DX IC are all CMOS devices for absolute minimum current consumption. The interface ICs are made in PL-integrated injection logic—which is well-known for its low current needs, high speed,

and low supply voltage requirement.

Power is supplied by two miniature batteries, which provide a voltage of 3 V—sufficient for most of the ICs. The 1.3 V supply for the CCD is obtained from a DC-to-DC converter. Although the current consumption of the electronic circuits has been kept to an absolute minimum, the batteries have to be capable of providing up to 2 A, which is the peak current drawn by the autofocus motor in operation.

The camera has a built-in voltage detector that switches off the whole of the electronics when the battery voltage drops below a certain value. There is an aspect here that needs watching. Certain alkaline-manganese—MnO₂—batteries, particularly Mallory and Ucar, after a period of use, appear to have an increasing internal resistance when relatively heavy currents are drawn with the obvious result that the electronics are switched off prematurely.

HB

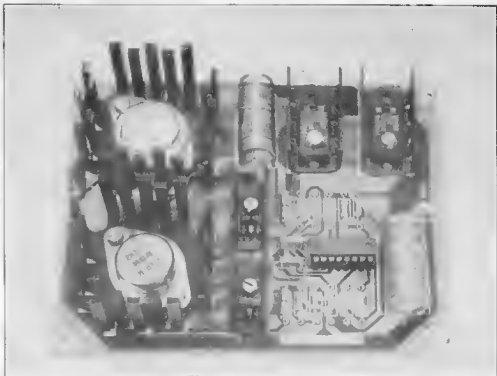

Mains-operated NiCd chargers are in plentiful supply, but a NiCd charger that operates from a car battery and enables fast charging is something special. The one described here can charge 9, 12, or 15-volt batteries.

DC OPERATED BATTERY CHARGER

Lowering the e.m.f. — electromotive force — of a car battery is easily done with the aid of a resistor, zener diode, or voltage regulator, but raising it is rather more difficult. The method chosen here is the familiar one of voltage doubling. How this is done in this charger is illustrated in Fig. 1.

In Fig. 1a, switch S connects the negative terminal of electrolytic capacitor C_2 to earth, so that both C_2 and C_1 are charged to the (car battery) supply voltage U_b :

$$\begin{aligned} U_{C1} &= U_{C2} = U_{D2} + U_{C3} = \\ U_{D2} + U_b - U_{D1} &= U_b \end{aligned} \quad (1)$$

In Fig. 1b, switch S connects the

negative terminal of C_2 to U_b , so that the output voltage, U_o , becomes:

$$U_o = U_{C4} = U_b + U_{C2} - U_{D2} = 2U_b - U_{D2} \quad (2)$$

When the switch is returned to earth as in 1a, the potential across C_2 remains at U_b , because C_2 cannot discharge. It is clear from this that U_o ($=U_{C4}$) will alternate between U_b and $2U_b - U_{D2}$. If the switching speed is high enough, the output voltage will approach $2U_b - U_{D2}$.

Circuit description

In practice, the switching is carried

out by a Darlington pair of transistors: T_1 , T_2 and T_3 , T_4 in Fig. 2. These transistors are controlled by an integrated circuit Type LM3524. Two of its features make this device particularly suitable for the present application: the push-pull output stage, which can drive the switching transistors, and the error amplifier. The error amplifier controls the width of the pulses at the input of the push-pull driver stage on the basis of the error signal at the output of the charger. The larger the deviation of the output current from the wanted value, the shorter the switch-on time of the power transistors carrying the output current.

The voltage doubling circuit consists

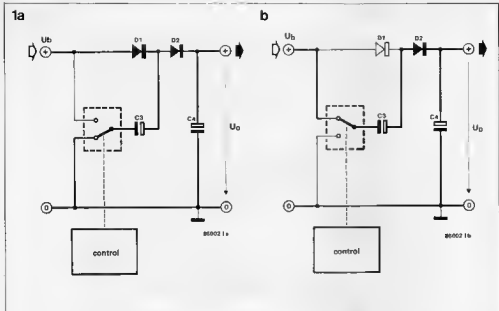

Fig. 1 In a, both C_3 and C_4 are charged to U_i minus the small drop across the relevant diode. In b, the output voltage is the sum of the voltages across C_3 and C_4 minus the drop across D_2 . The switch is controlled by an oscillator, modulator, and regulator.

of capacitors C_3 and C_4 and diodes D_1 and D_2 . These diodes are fast recovery power types in a TO-220 case, which is readily mounted onto a heat sink. An oscillator in the LM3524 generates a rectangular signal for the T-type bistable and the two NOR gates, and a sawtooth signal that is applied to the non-inverting input of a comparator. The frequency, f_0 , of the oscillator is

$$f_0 = 1/2\pi R_1 C_1 = 1/295 \times 10^4 = 3400 \text{ Hz.}$$

A reference voltage of 2.5 V is provided by divider R_7 - R_8 and applied to the non-inverting input of the error amplifier. The inverting input of this stage is provided with information as to the level of the output voltage via divider R_2 - R_1 .

The comparator here functions as a pulse-width modulator. Depending on the level of the error signal at its

inverting input, and the level of the triangular signal at its non-inverting input, the comparator produces a rectangular signal with varying pulse-width at its output. This output constitutes the real control signal for the power transistors. To ensure synchronicity and a 180° phase shift, the comparator output is applied to the bases of the drive transistors via two NOR gates. Pulse-width control has the advantage that the average

Fig. 2 The circuit of the battery charger consists essentially of the control which is contained in one Type LM3524 integrated circuit, power switching transistors T_1 to T_4 and the voltage doubler comprising D_1 , D_2 , C_3 and C_4 .

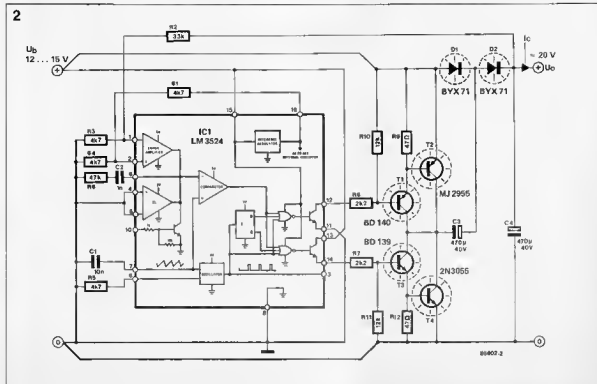

Parts list

Resistors:

$R_1, R_3, R_4, R_5 = 4k7$
 $R_2 = 33k$
 $R_6 = 47k$
 $R_7, R_8 = 2k2$
 $R_9, R_{12} = 47 \Omega$
 $R_{10}, R_{11} = 12k$

Capacitors

$C_1 = 10n$
 $C_2 = 1n$
 $C_3, C_4 = 470\mu, 40V$
 (axial types)

Semiconductors

$D_1, D_2 = BYX71$
 $T_1 = BD140$
 $T_2 = MJ2955$
 $T_3 = BD139$
 $T_4 = 2N3055$
 $IC_1 = LM3524$

Miscellaneous

2 twisted vane TO220 heat sinks
 2 twisted vane TO126 heat sinks
 2 TO3 style heat sinks
 PCB 86002

Fig 3 The whole of the battery charger, down to the heat sinks, is contained on this printed circuit board

Fig 4 The output current vs output voltage shows that the output voltage remains substantially constant for load currents up to 3 A

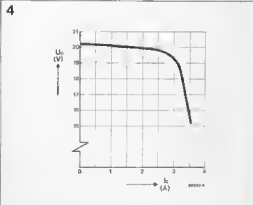

3

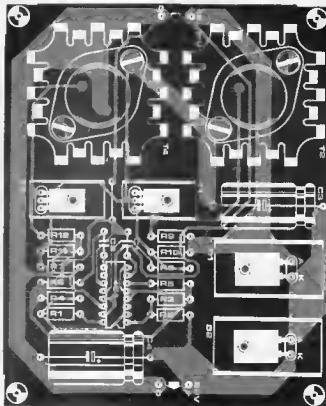

load current remains substantially constant.

The current limiter — CL_1 — in the LM3524 is not used in this application.

Construction and test

All components, as well as the heat sinks of the switching transistors, T_1 to T_4 , and the power diodes, D_1 and

D_2 , are fitted on the printed circuit board shown in Fig. 3. If the board is fitted in a case, there should be sufficient space above electrolytic capacitors C_3 and C_4 to ensure good ventilation.

Once the board has been completed, the open-circuit output voltage should be measured. This should be somewhat higher than 20 V. Note that a perfect voltage doubling, i.e. from 12 V to 24 V, is not possible because of the saturation voltage of power switching transistors T_1 and T_2 and the forward drop across the power diodes.

Next, the behaviour of the circuit under load should be checked with reference to Fig. 4. Our laboratory prototype has an open-circuit output voltage of 20.2 V. Under normal load conditions, the output voltage remains substantially constant (± 0.5 V) until the load current exceeds 3 A.

Fast charging

During fast charging, the charging current must, of course, be limited in accordance with the requirements of the cells or battery under charge. For

example, NiCd cells are normally charged with a current, I_c , of 120 mA to 400 mA. If ten of these cells are charged in series, there will be a drop, U_d , of 15 V across them. A current limiting resistor, R_9 , should then be used, whose value is calculated from

$$R_9 = (U_0 - U_d) / I_c = (20 - 15) / 0.4 = 12.5 \Omega$$

The power, P_9 , dissipated in R_9 is calculated from

$$P_9 = I_c^2 R_9 = 0.4^2 \times 12.5 = 2 \text{ [W]}$$

Sintered-plate cells are normally rated at 1.2 Ah, and may be fast-charged with a current of 2.5 A for thirty minutes. HS GS

SATELLITE TV RECEIVING EQUIPMENT

In satellite television, programmes are beamed up to a satellite from where they are retransmitted to serve an area (called footprint) that is impossible to cover with a terrestrial aerial. The satellites used for this are geostationary, that is, they orbit at the same speed as the earth's rotational velocity. This makes it possible for a receiving aerial (called dish) to be firmly locked into position. Any dish within the footprint should receive good-quality sound and vision. There are several satellites dedicated to broadcasting programmes, and these are known as Direct Broadcast Satellites —DBS. Among these are the Russian Gorizont satellites which send programmes across the world to official Soviet expatriot groups. Such satellites have very powerful transmitters, so that only small dishes are required to receive their signals. Whilst many European countries, including France, Federal Germany, and the Republic of Ireland, are planning to launch and build DBSs, British plans to establish a DBS have been abandoned, at least for the time being, because of the enormous costs in-

olved. Until DBS gets well and truly off the ground, programme makers, such as Sky Channel and Thorn EMI, have turned to communications satellites with spare capacity that can be used to broadcast programmes. The transmitters on board these satellites

are generally weaker than those employed in DBSs, but reception is just as good with a (larger) 1.8 metre dish. There are at present two primary satellites that transmit programmes to western Europe. One is Intelsat V, and the other is ECS-1 (European Com-

munications Satellite 1). Between them they broadcast seventeen channels, most of them in English. Both Intelsat V and ECS-1 are communications satellites used primarily to route telephone calls across Europe and to the USA. The footprints of these satellites are shown in Fig 1 and 2.

The NESAT system from NEC Business Systems has been designed to plug into existing TV sets to deliver multi-channel television to a variety of consumers. With this system, customers need not wait to be hard-wired to a cable network, nor do they have to wait for DBSs to be launched. The NESAT system has several unique features that may place the equipment well ahead of the competition in the race to become the number 1 supplier of satellite TV receiver systems designed specifically to meet the high standards demanded by the British and

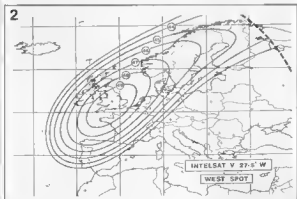
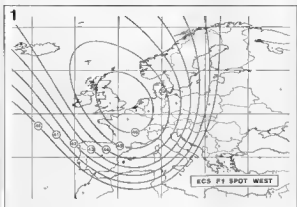

Fig 1 Coverage area ("footprint") of European Communications Satellite 1

Fig 2 Coverage area ("footprint") of Intelsat V

Channels currently available

(1) via Intelsat V:

Premiere — which shows recent box office movies for about nine hours a day.

Children's channel — with programmes aimed exclusively at young children and teenagers for eight hours every day.

Screen sport — sports and leisure programmes for six hours every day.

MirrorVision — movies and entertainment programmes for nine hours every day.

CNN — a 24-hour news channel.

(2) via ESC-1:

Music box — pop music programmes for 18 hours every day.

Sky channel — general entertainment for 16 hours every day.

TV-5 — programmes from national French language stations for 3 hours a day.

New world channel — a diet of religious programmes for 1 to 6 hours a day

WorldNet — news and information programmes from the US Information Agency for about 1 to 2 hours every day

SAT1 — a publishers channel broadcasting about 10 hours a day

TeleClub — broadcasts mainly films for about 8 hours a day.

FilmNet AIN — mainly films and entertainment for about 9 hours every day

World Public News (WPN) — mainly US news material for about 9 hours every day.

JSAT — programmes from German language stations for about 6 hours every day.

RAI — an Italian public service channel.

Europa TV — (formerly Olympus TV): programmes from European Broadcasting Union — EBU — member stations for approximately 3 hours a day.

RTL-Plus — general entertainment for five hours a day.

With the exception of Sky Channel, all these channels are at present clear, i.e. they require no decoding system.

European markets.

The NESAT system comprises three main components: dish, low-noise converter (LNC), and indoor unit (IDU) tuner. Planning permission may be required for the erection of the dish in certain circumstances at the present, but restrictions and regulations are likely to be relaxed in the near future. Many of the current regulations covering broadcast were evolved some time ago, when the possibility of utilizing near-earth orbiting satellites was undreamed of.

The low-noise converter has a low-noise amplifier

that uses gallium-arsenide (GaAs) field-effect transistors which reduce noise and thus increase picture quality.

The IDU tuner enables the user to preset different parameters adopted in the ECS-1 and Intelsat V satellites for each channel. Selecting channels is from then on simply a matter of pressing the appropriate button on the front of the tuner. The tuner is designed for use with any type of television receiver.

The unique feature of the NESAT system is the facility for simultaneous reception of differently polarized



signals. Channel operators use either X or Y polarization. NESAT is the only system capable of receiving signals with both types of polarization and passing them on to the TV set via one cable.

NEC Business Systems (Europe) Limited is the British subsidiary of the NEC Corporation, which is the recognized industry leader in a variety of high technology electronics sectors. It is one of the leading and one of the largest electronics manufacturers in the world, with 70 plants throughout the world, and more than 74 000 people

Fig 3 NEC's 1.6 m dish with two low-noise converters, which are stacked to enable simultaneous reception of horizontally (X) and vertically (Y) polarized signals

Fig 4 Close-up of two stacked low-noise converters, mounted onto the dish as shown in Fig. 3

Fig 5 NEC's IDU (indoor unit) tuner, designed to sit below or above the TV set, is slimmer than most video recorders

making and marketing products that are sold in 140 different countries. NEC's experience in high technology space related telecommunications systems goes back some 45 years. Around the world, there are no fewer than 6000 NEC-equipped microwave stations, while satellite communications earth stations (recognizable by their large dish aerials and which have become a symbol of the 20th century) manufactured and supplied by NEC account for almost 50 per cent of the world's total installations. NEC are also involved direct in manufacturing equipment for use in television transmitters, and the company has had some 15 years' experience in transponder design. It recently won a contract to supply transponders for use in all the Intelsat VI series of communications satellites. Transponders are the devices on board satellites that receive signals from earth stations and relay them back to receiving systems. Satellite TV Antenna Systems claims to have achieved a breakthrough in satellite TV reception by cutting the cost of receiving equipment by half, largely through technical development, and expects that private ownership of such equipment will consequently be enlarged.

The company, known as SATVRN, is offering complete systems that retail at starting prices of less than £1000.

The systems have three elements: the dish aerial, which receives signals from the satellite; the electronics head unit, mounted on the dish, which amplifies the signals and converts them for TV reception; and the tuner, which is plugged into the TV set.

Dishes 1.2 metres across supplied by SATVRN can be mounted in the garden of a small home, on an outside wall, or on the roof.

The firm also offers satellite master aerial TV (SMATV) systems, which are commercial installations suitable for hotels, housing estates, and apartment blocks. Hotels using these systems can offer TV programmes from their own countries to foreign guests, for instance. SATVRN has supplied equipment to the US Navy, the European Space Agency, and customers in western Europe, Yugoslavia, Israel, the Gull States, and Canada. Another breakthrough in satellite TV receiving equipment occurred in the home of electronics engineer Mr Steve Webb of Swinton, near Milton, N Yorks. His three children induced him to design a

simple means of receiving information being broadcast by spacecraft. According to Mr Webb, "games are useful to help youngsters get interested in computers, but they can become a total misuse of the technology. My children got fed up playing space invaders, so we set about trying to communicate with two British satellites to get information and pictures". Using the know-how he had acquired in 10 years' work on satellite systems with two major UK space companies, he worked for fifteen months to produce a receiving system that converts satellite signals and decodes them via a computer onto a TV screen.

"The first receiver I built for the children was crude," said Mr Webb. "So, I decided to develop a fully automatic model for any one to use". The result is a fully automatic version called ASTRID, acronym for Automatic Satellite Telemetry Receiver and Information Decoder. The total cost of ASTRID and accessories is £149. One of the biggest associations of computer users has described the device as an "outstanding product and a major breakthrough, bringing many exciting opportunities to amateur scientists and radio amateurs". Mr Webb believes the device will particularly appeal to schools in a whole range of related subjects ranging from geography and maths to science and computer and radio technology. The research and development work was funded by the Micro Metalsmiths Microwave Company of Kirkbymoorside, N. Yorks, which Mr Webb joined last year.

ASTRID is reported to be attracting worldwide interest following tests by science teachers throughout Britain, associations of computer users, and trade publications.

NEC Business Systems (Europe) Limited
35 Oval Road
London NW1 7EA
Telephone: (01) 267 7000
Telex: 265151
Fax: (01) 267 1645/1641

Satellite TV Antenna Systems Limited
10 Market Square
Staines
Middlesex TW18 4RH
Telephone (0784)
61234/52155
Telex: 877440

Fig 6 NEC manufactures and installs almost 50 per cent of the world's satellite communications earth stations, such as the one shown here

Fig 7. Typical transponder as supplied by NEC for use in the Intelsat series of satellites

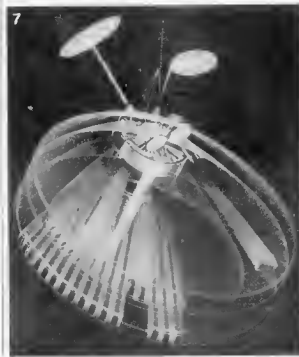

DESIGN
IDEAS

ACTIVE AERIAL WITH SMDS

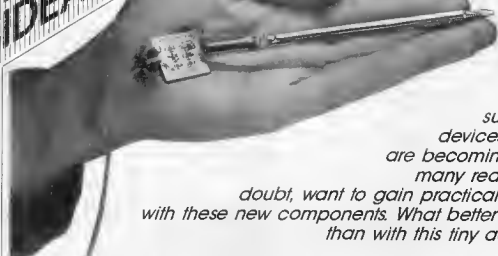

Now that surface-mount devices — SMDs — are becoming available, many readers will, no doubt, want to gain practical experience with these new components. What better way to start than with this tiny active aerial?

As stated in *Surface-mount Technology* (Elektron India, January 1986),

all major semiconductor manufacturers are heavily engaged in the development and production of surface-mount components. These components are much smaller than conventional ones and have no or very short connecting terminals, since they are intended to be soldered direct to the copper tracks of a circuit board. In general, these boards no longer have holes drilled in them, other than for fixing purposes.

It should be noted that, although all major manufacturers have a good range of SMDs in production, these devices may not yet be available from all distributors and stockists.

Circuit description

The active aerial presented here is a very simple circuit, which is primarily intended as a practical introduction to

working with surface-mount devices. It has been designed as an add-on unit for a car aerial and for portable receivers where a 12 V supply is available. The aeriads used with these receivers usually have a fairly high resistance, whereas the receiver input impedance is typically of the order of 50 to 100 ohms. The resulting mismatch has a detrimental effect on the noise figure of the receiver.

The present circuit provides a large degree of correct impedance matching via a dual-gate MOSFET, T₁. The aerial signal is applied to gate 1 of the device, while the potential at gate 2 is arranged at half the supply voltage, i.e., 4.5 to 6 volts. The MOSFET amplifier is coupled to the receiver input via a short length of screened 75-ohm cable (as normally used in car radios). The conductor in this cable also serves to connect the supply voltage to T₁. The chokes present a high impedance to frequencies in the receiver range, so that

they cannot enter the receiver via the supply line. The 560 pF capacitor isolates the receiver input circuits from the DC supply.

Note that the MOSFET has a typical mutual conductance of 20 mS, so that it performs best with output impedances greater than 50 ohms. As the medium- and long-wave input circuits of car radios are normally high impedance, the present circuit will work well on those wavebands. FM receiver inputs are generally low-impedance, so that the circuit will not be so effective on the VHF bands.

Construction

Note that the circuit board is not available ready made through our Readers Services. It is best made from the pattern on page 44 or from a piece of prototyping board. Soldering should be carried out with an iron rated at no more than 18 watts and fitted with a sub-miniature tip to prevent damage to the fragile surface-mount devices. The

tip may be made from a length of SWG20 (1 mm dia) bare copper wire wound around the heating element of the iron. Useful tips on mounting the devices are given in *Surface-mount Technology* in the January 1986 issue of *Elektron India*.

The component layout is shown in Fig. 2. In portable radios it is advisable to solder the aerial termination direct to C₁. Note, however, that the present circuit can only be used if the portable radio has a separate aerial input that bypasses the built-in ferrite aerial.

Finally

Since it is impossible to achieve absolutely correct impedance matching, the cable between the present circuit and the receiver may radiate. If the resulting signal is picked up by the aerial, the MOSFET stage may oscillate. All this can be prevented by winding the initial length of the connecting cable around a ferrite toroid or rod as shown in Fig 3

Fig. 1 Circuit diagram of the proposed active aerial in which all electrical components — except the chokes — are surface mount devices

Fig 2. Circuit board showing a possible layout of the active aerial circuit. This board is not available ready made, but may be made from a piece of prototyping board. Its dimensions are about 250x250 mm.

Fig 3. Any tendency of the connecting coaxial cable to radiate may be suppressed by winding its initial length around a ferrite rod or toroid.

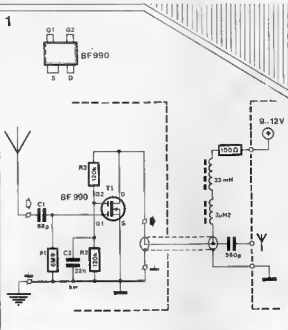

DESIGN IDEAS



The aerial resistance is the ratio of the power supplied to it and the mean square value of the current at its feed point. This resistance takes into account the energy consumed by the aerial system as a result of radiation and other losses.

The noise factor, F , of a receiver is the ratio of the input power, P_0 , and the noise output power, N_0 : $F = P_0/N_0$. The noise figure is often expressed in decibels: $F_{dB} = 10 \log_{10} F$.

Mutual conductance, g_m , is the ratio of a change in output current to the causative change in input voltage when the output voltage is held constant. It is expressed in siemens — S — which has replaced, and is equivalent to, the mho (reciprocal of ohm).

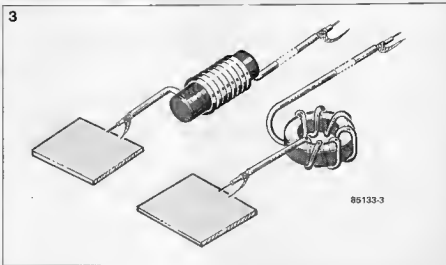
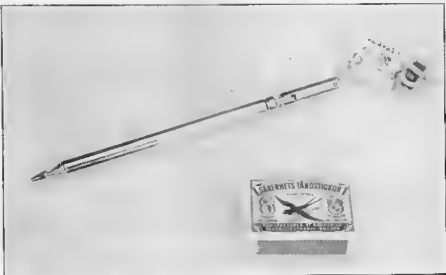

85133-3

Cartridge board with user-programmable EPROM

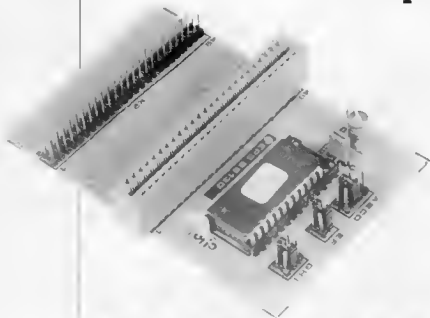

MSX

EXTENSIONS - 2

Second in the series on home-made MSX add-on units, this article presents a cartridge extension board and full details on EPROM-stored programs.

As evidenced by the first part in this series *Elektor India* February 1986), the cartridge slot available on MSX type computers may be used to effect connection of home-made extensions like the Elektor universal I/O bus.

Usually, commercially available cartridges merely contain an (E)PROM to run a program (game, utility). It is, therefore, possible to construct a device that will hold user-programmed EPROMs whilst retaining the possibility to insert existing cartridges. Our design offers the following facilities:

1. Easy connection of further hardware-extensions, like the Elektor universal I/O bus.
2. The present board may be connected to the existing 50-way output port of such MSX computers as the Spectravideo type.
3. The board may be used as an angled cartridge adapter or a versatile IC socket to hold several types of user programmable EPROMs with 2, 4, 8, 16, or 32 Kbytes capacity.
4. The board is useful for the connection of a Yamaha synthesizer.

The MSX cartridge

As shown above, the present cartridge extension board is the sort of design that many users would undoubtedly like to see: universal, accessible for measurements and experiments and with the possibility to insert one's own EPROMs. However, before this can all come true, some knowledge is required of the 'cartridge conventions' used in MSX BASIC. We shall, therefore, first examine a typical MSX start-up procedure.

After power-on, MSX BASIC always establishes the amount of RAM (Random Access Memory) between addresses 8000 and FFFF, and activates the largest continuous area encountered. Next, BASIC examines slot address range 4000..BFFF. Each slot occupies 16 Kbytes, divided in four pages. At the beginning of every page, a sequence of codes is read to identify the slot contents. The bytes which supply this information are located in a fixed order, as shown in Fig. 1. The function of each code is as follows:

ID (identification): a two-byte code that indicates the presence of a cartridge (EPROM). In that case, BASIC reads 41_{hex} and 42_{hex} (ASCII A and B), respectively at these locations.

INIT (initialization): a vector (address pointer) for the initialization routine associated with the cartridge func-

tion. In case this is not required, a default value 0000 is present at these locations.

STATEMENT: a vector pointing to the cartridge statement-handler, if applicable. If not, a default 0000 is present. For further details on this vector, refer to the user manual supplied with the computer or the cartridge.

DEVICE: a vector pointing to the cartridge device-handler, if applicable. If not, a default 0000 is present. Refer to computer manual for further details.

TEXT: a vector pointing at the token-coded BASIC program text in the cartridge. This pointer is of great interest to users who want to put their own BASIC programs into EPROMs. All foregoing addresses are stored in the cartridge (EPROM with their least significant byte (LSB) first, as is customary in Z80 machine language programming

cuit at all; it is rather a truly universal and user-friendly IC socket for the 27XX series of EPROMs, ranging from the well-known Type 2716 (2 Kbytes) to the giant Type 27256 (32 Kbytes). Note that EPROM manufacturers have generally agreed on using the last two or three digits of the type indication to state the memory capacity in kilobits. Divided by eight, this will give the number of programmable bytes (one byte equals eight bits).

To accommodate every member of the 27XX family, the present extension board has a number of jumpers, which will have to be installed or removed as follows:

jumper A selects between Types 27128 and 27256 EPROMs and should be installed with the latter type inserted.

jumper B connects terminal 27 of a Type 27128 to +5V. Thus: jumper A for a 27256, jumper B for a 27128.

jumper C connects V_{CC} terminal 24 of 24-pin Types 2716 and 2732 to +5V.

jumper D connects address line A₁₃ to terminal 26 of 28-pin Types 27128 and 27256. For the 2764, jumper C

must be installed (pin 26 to +5V, not both jumpers C and D).

jumper E connects terminal 23 (28-pin types) or terminal 21 (2732) to A₁₁ and must be installed for all EPROMs except Type 2716.

jumper F connects V_{PP} terminal 21 of a Type 2716 EPROM to +5V.

jumpers G, H, and I connect the EPROM CE terminal (chip enable) to MSX signal CS₁, CS₂ or CS₁₂ in that order. CS₁ being the ROM select signal valid for address range 4000..7FFF, CS₂ for 8000..BFFF, and CS₁₂ for both ranges, i.e. 4000..BFFF. Up to and including a Type 27128 EPROM, either CS₁ or CS₂ is used; a Type 27256 requires the CS₁₂ signal. Table 1 summarizes all available jumper configurations in order that any user can readily find and set the jumper combination as required for the EPROM in use.

So far, only EPROMs have been mentioned because these are most readily available and programmable. However, it will be evident that pin-compatible proprietary PROMs or ROMs will work just as well.

If fitted in the MSX computer, the in-



Fig 1 These codes at the beginning of every slot address-block form a software 'visiting card' of the cartridge, for identification by MSX BASIC

Practical circuit

Actually, the present design, as shown in Fig. 2, is not much of a cir-

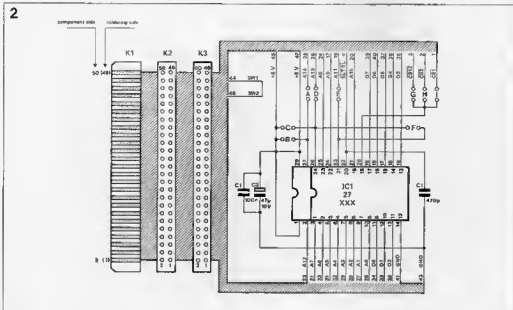

Fig 2 Practical circuit of the cartridge extension board. The jumpers are set to suit the type of EPROM used (2 32 Kbyte)

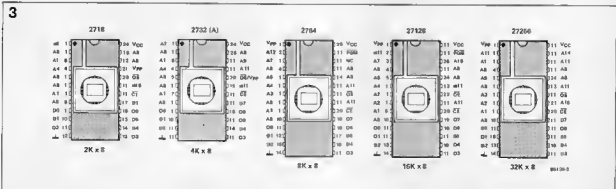

Fig 3 Pin designations of the popular 27XX series of EPROMs, arranged in order of memory capacity

Listing 1 This memory dump program may be used to analyse larger BASIC programs as they reside in RAM; it provides hexadecimal presentation of any given memory area and may be put in EPROM to function as a stand by utility cartridge

Listing 1.

DUMP

```

10 CLS
20 INPUT "start":A
30 INPUT "end":B
40 FOR C = A TO B
50 LPRINT USING "\ \";HEX$(C);:LPRINT " ";
60 FOR D=0 TO 15
70 LPPINT USING "\ \";HEX$(PEEK(C+D));:LPRINT " ";
80 NEXT
90 C=C+15:LPRINT " ":LPRINT " "
100 NEXT
110 END

```

Parts list

Capacitors: C1 - 470p
C2 - 100n
C3 - 47µ, 10V

Semiconductors

IC1 - 2716, 2732, 2764;
27128, 27256 or corre-
sponding pin-compat-
ible EPROMs

Miscellaneous

K2 - 50-way (2 x 25)
male PCB connector
K3 - 50-way (2 x 25)
MSX female slot con-
nector, 0.1 inch pitch
18 way (2 x 9) male
locking plug assembly
for female jumpers
(e.g. Minicon Latch PL
18w)
4 jumpers
PCB 85130
(65.5 x 98mm)

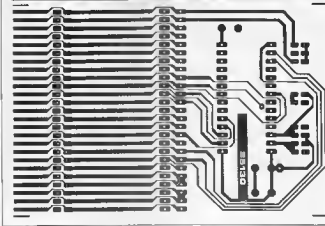
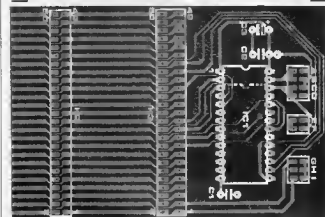
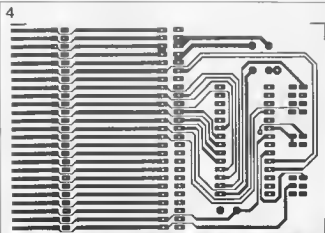

Fig 4 This through-plated PCB is small but effective when it comes to plugging in existing cartridge hardware extensions, or EPROMs holding user programs

ser/remove protection circuitry will detect the connection between SW1 and SW2 as present on the extension board.

Three connectors are provided on the board; K₁ is simply the edge of the extension board with connecting copper tracks on both sides for insertion in the computer cartridge slot, PCB connector K₂ is a standard male 50-way type (2 rows of 25 pins); while K₃ is a cartridge slot connector with 0.1 inch pitch contacts, just as the one inside the computer.

Construction

Track layout and component mounting plan of the cartridge extension board are shown in Fig. 4. The ready-made PCB is a moderately sized, through-plated type, available as usual through our Readers Services. The soldering islands and slot connecting tracks have been pre-tinned to guarantee stable contacts. Use of a 28-way ZIF (zero insertion force) socket is highly recommended because sooner or later EPROMs will have to be taken out, erased with a UV source, programmed again, debugged, etc., and this perhaps several times. The cheaper types of IC socket will inevitably develop bad terminal contacts after prolonged use...

Applications

Now that a neat, universal (EPROM) socket is available, frequently used programs may be stored in a dedicated EPROM, just as with commercially available cartridges, but a good deal cheaper. However, before user programs may be successfully stored in EPROM, the MSX BASIC program storage method needs to be unravelled.

Note that the following description does not apply to machine-coded cartridge programs, since these require a more elaborate vector system. For a BASIC program, then, the ID and TEXT vectors are essential; they are located at XX00-XX01 and XX08-XX09 respectively (see Fig. 1). Because the first 16 bytes of the cartridge (EPROM) are reserved for program identification and system vectors, the token coded BASIC program itself may be stored from location XXI0 onwards.

MSX BASIC programs are generally stored in memory from address 8000 onwards, so the value 80 may be read for XX from now on.

At 8010, the CPU must invariably read byte 00. The next locations contain a so-called link address (two bytes) and a line number (also two bytes);

next comes a token-coded line of BASIC text, terminated with a byte 00. This procedure is repeated for the following text lines.

To find out the hexadecimal codes that constitute a program, it is necessary to run the DUMP program of Listing 1, preferably with a printer connected to the computer. In case a printer is not readily available, the bytes may be put on the screen by changing all LPRINT commands into PRINT and next changing value 15 into 7 in lines 60 and 90 to allow for the reduced number of printable characters per line. Note that the DUMP program may be 'attached' to any user program in memory by entering it from, say, line 10000 onwards.

After RUN 10000 the program prompts for a start and end-of-program address; the former is always &H0000 the latter depends on the actual size of the program, which

	A	B	C	D	E	F	G	H	I
27256	00			00	00		00		
27128		00		00	00			00	00
2764		00	00		00			00	00
2732			00		00			00	00
2716			00			00		00	00

= jumper
* = select either H or I (see text)

00130 T1

Table 1
Summary of the necessary jumper configurations for every type of EPROM in the 27XX series. The choice between jumpers H and I depends on the selected memory area (see text).

Table 2.

	0	1	2	3	4	5	6	7	8	9	A	B	C	D	E	F
8000	0	7	80	A	0	9F	0	16	80	14	0	85	22	87	74	61
			L8067	*10	Tk	EOL		L8016	*20	Tk				s	t	a
8010	72	74	22	3B	41	0	23	80	1E	0	85	22	65	6E	64	22
	t	"	:	A	EOL		L8023	*30	Tk		e	n	d	"	"	"
8020	3B	42	0	33	80	28	0	82	20	43	20	EF	20	41	20	D9
	:	8	EOL	L8033	*40	Tk	sp	C	sp	Tk	sp	A	sp	Tk	Tk	
8030	20	42	0	4E	80	32	0	90	E4	22	5C	20	20	5C	22	3B
	sp	B	EOL	L804E	*50	Tk	Tk	"			sp			"	"	:
8040	FF	9B	28	43	29	38	3A	90	22	20	20	22	3B	0	5D	80
	Tk	Tk	(C)	:	Tk	"	sp	sp	"		EOL	L8050		
8050	3C	0	82	20	44	EF	11	20	D9	20	F	F	0	7B	80	46
	*60	Tk	sp	D	Tk	0	sp	Tk	sp	Tk	15	EOL	L8076			*
8060	0	9D	E4	22	5C	5C	22	3B	FF	9B	20	FF	97	28	43	F1
	70	Tk	Tk	"			:	Tk	Tk	(Tk	Tk	(C	Tk	
8070	44	29	29	3B	3A	9D	22	20	22	3B	0	81	80	50	0	83
	O))	:	:	Tk	"	sp	"		EOL	L8061	*80	Tk		
8080	0	96	80	5A	0	43	EF	43	F1	F	F	3A	90	22	20	22
	EOL	L8096	*90	C	Tk	C	Tk	C	Tk	Tk	15	:	Tk	"	sp	"
8090	3A	9D	22	20	22	0	9C	80	64	0	83	0	A2	80	6E	0
	Tk	"	sp	"	EOL		L809C	*100	Tk	EOL	L80A2				*110	
80A0	81	0	0	0	8	41	0	C5	32	76	80	0	0	0	0	8
	Tk	EOL			A											
80B0	42	0	C5	32	51	20	0	0	0	0	8	43	0	C5	32	59
	B										C					
80C0	0	0	0	0	0	8	44	0	41	90	0	0	0	0	0	0
						D										
80D0	3A	0	0	0	0	0	0	0	0	0	0	0	0	0	0	0
80E0	0	0	0	0	0	0	0	0	0	0	0	0	0	0	0	0
80F0	0	0	0	0	0	0	0	0	0	0	0	0	0	0	0	0
8100	0	0	0	0	0	0	0	0	0	0	0	0	0	0	0	0

* line number *nn*
L: Link address *llh*
Tk: Token byte
sp: space
EOL: end of BASIC line
□: end of program

Table 2 This table is a hexadecimal dump of the DUMP program as it resides in MSX computer RAM memory. All bytes have been analysed, and it may be useful to reconstruct program Listing 1 from it!

Table 3 These data are burned into an EPROM to function as a utility cartridge called DUMP. Compare the shaded addresses with those in Table 2 to note the move up by 10_{hex} and the correspondingly adapted LSBs

Table 3

	0	1	2	3	4	5	6	7	8	9	A	B	C	D	E	F
8000	41	42	0	0	0	0	0	0	10	80	0	0	0	0	0	0
8010	0	17	80	A	0	9F	0	26	80	14	0	85	22	73	74	61
8020	72	74	22	36	41	0	33	00	1E	0	85	22	65	6E	64	22
8030	3B	42	0	43	80	26	0	82	20	43	20	EF	20	41	20	09
8040	20	42	0	5E	80	32	0	9D	E4	22	5C	20	20	5C	22	38
8050	FF	98	20	43	29	3B	3A	9D	22	20	20	22	38	0	6D	80
8060	3C	0	82	20	44	EF	11	20	D9	20	F	F	0	8B	00	46
8070	0	9D	E4	22	5C	5C	22	36	FF	98	28	FF	97	28	43	F1
8080	44	29	29	38	3A	9D	22	20	22	36	0	91	80	50	0	83
8090	0	A6	80	5A	0	43	EF	43	F1	F	F	3A	9D	22	20	22
80A0	3A	9D	22	20	22	0	AC	80	64	0	83	0	B2	86	6E	0
80B0	B1	0	0	0	0	0	0	0	0	0	0	0	0	0	0	0

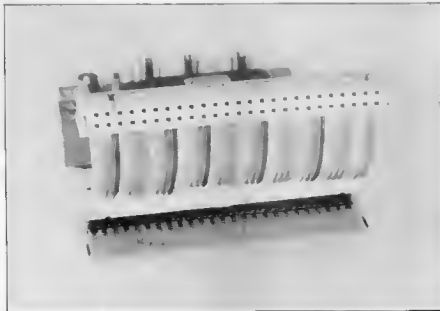

Fig 5 The Spectravideo MSX computer may be connected to the cartridge extension board with a short length of 50-way ribbon cable and two suitable sockets

is lengthened by some 160 bytes because of the addition of DUMP. After this first acquaintance with the hexadecimal dumping format and use of DUMP in practice, the computer memory may be cleared (NEW) and DUMP entered as shown in Listing 1, i.e. from line 10 onwards. Run DUMP, enter &H6000 as the start address and &H8100 as the end, and have a look at the machine code that constitutes this little program. With the use of Table 2, try to retrace the familiar BASIC lines to understand the MSX memory storage principle. Note that the link addresses and line numbers are in reverse order, that is with their LSBs first. All standard BASIC commands have a corresponding token-byte, and it will not be difficult to spot some of them:

82h=FOR; 9Dh=LPRINT; EFh="=" (equal sign); 83h=NEXT; F1h="+"; E4h=USING; etc.

If this is all sufficiently clear, we will now consider the EPROM data.

EPROM data

It will be evident that the computer does not consider the machine code currently present in locations 8000 and up as located in a cartridge, because the identification group of bytes as already discussed is not present at the beginning of the program (8000...800F). To obtain factual EPROM data, the whole machine code program will have to be moved up by sixteen (10_{hex}) bytes, the link addresses changed accordingly, and the identifiers placed at the beginning as outlined above.

A practical example of how this may be accomplished is shown in Table 3; this is the DUMP program again, but this time as present in an EPROM; compare the data with those of Table 2 to gain an insight into cartridge EPROM operation with MSX BASIC; program an EPROM with these data, plug it into the cartridge ZIF socket, and run your own utility cartridge.

Finally, a word about lengthier, more

complicated BASIC programs and their storage in EPROM. As already suggested, the DUMP program may be attached to them at a suitable high line number, e.g. 10000. With the main program fully debugged and operational, run DUMP, spot the link addresses, add 10_{hex} to them, move the program up by 10_{hex} addresses, and write a suitable sequence of identification bytes. The link addresses always point to the next one, and are thus easily picked out for modification. Program end is marked by a link address reading 0000, but the real end, that is without the added DUMP program, may be found by looking for the hexadecimal equivalent of 10000 bytes 1027 in that order; next, change the preceding link address into 0000. Finally, note that programs run from cartridge may, of course, not be edited because they reside in read-only memory.

Spectravideo connection

The extension board need not always be inserted into the computer's cartridge slot; the Spectravideo MSX computer, for instance, features a 'real' 50-way expansion connector for receiving an appropriate flat ribbon type socket. The present extension board is then connected with a short length of 50-way flat ribbon cable with such a socket on either end of it, as shown in Fig. 5. Note that there is a slight oddity with the Spectravideo output expansion connector; the tiny arrow on it does not indicate pin 1 as usual practice, but pin 50. However, no problems should be encountered if the example given by Fig. 5 is followed.

This finishes the present article on MSX extensions; a further instalment will deal with the construction of a bus-board for this type of computer.

GD:BL

THE FUTURE FOR ARTIFICIAL INTELLIGENCE

by Professor Margaret A. Boden, MA(Cantab), PhD(Havard), FBA

Despite its short history, artificial intelligence already promises to change everyday life as much as the Industrial Revolution did.

Machine intelligence was foreseen in the 19th century by Charles Babbage, whose cogs-and-gears calculating machine worked in a way basically similar to today's computers. A century later, Alan Turing provided a theory about what questions could in principle be answered by such a machine. Artificial intelligence grew out of the work on digital computers in World War II, and was given the dignity of a name in 1956.

Since the early efforts in the mid-1950s, it has had some notable successes. Today's computers can perform some of the tasks normally done only by our minds — though only to a very limited degree. For instance, some programs can respond sensibly to queries or statements expressed in natural languages such as German or English — which means that ordinary people do not need to learn a special programming language before they can interact with them.

Expert systems

Conversations with most of these programs have to take place over a teletype, but some can recognize spoken words. Other programs can describe the shape and position of visible objects, and identify what they are. Still others can play games, or comment on events from a particular political standpoint. And some can solve

problems of various kinds, like those which an intelligent robot would have to tackle.

The most publicly visible applications so far are the programs called expert systems. Some are already being used experimentally to give advice on medical diagnosis and prescription, genetic engineering, chemical analysis, and geological prospecting for minerals and oil. Future expert systems will be used by ordinary families for example, to help motorists diagnose and fix faults in their cars.

An expert system has built into it some of the theoretical knowledge and rules of thumb used by human experts. And it can be improved, up to a point, by adding new information. So that it can help on a particular problem, it is given the evidence that its human user has — it can suggest that relevant tests be done, if they have not been done already. Then it supplies an opinion based on this evidence. To make it easier for people to evaluate its advice, the expert system can display its chain of reasoning.

Current expert systems are very limited in what they can do, however, largely because they cannot reason about their own reasoning, or the user's reasoning either. They cannot explain their conclusions differently to different people, since they have no user-model in terms of which to adjust their explanations to a person's level of knowledge. But despite their limitations, a few current systems give more reliable advice than all but the very best human experts, and one or two

surpass us all. The world expert on soya bean diseases, for example, is not a person but a program.

Long term funding

Government money from the western industrialized nations is being poured into artificial intelligence research, in both academic and industrial contexts. The European Community has established the ESPRIT project for funding co-operation between its member countries in research into micro-electronics and software technology. The first phase of ESPRIT will draw on £465 million from Community revenues.

The British Government, as well as having a stake in ESPRIT, has set up the national Alvey Committee to recommend a strategy for the long term funding of artificial intelligence and related computational techniques. Government funds of £215 million have been allocated for this information technology work.

The electronics industry is taking this research seriously too, matching ESPRIT's £465 million with an equal contribution. And the Government's £215 million is also equalled by industrial money set aside for the Alvey research and development projects.

What are these machines of the future, the so-called fifth generation computers? The first four generations are defined in hardware terms: machines based on valves, transistors, silicon chips, and very large scale integration (VLSI). The

predicted fifth generation is defined in terms not only of improved — massively parallel — hardware, but also of artificial intelligence.

Multi-lingual robots

It is hoped, for instance, to achieve reliable machine translation between various natural languages — even on texts that are not restricted to highly specialist subject matter. And some people forecast that computers of the 1990s will be able to interpret the speech of many different individuals, to act as intelligent assistants in a wide variety of tasks, and to provide advanced problem solving and sensori-motor abilities for mobile domestic and industrial robots.

However, achieving fifth generation computers will be much more difficult than most people assume. Once they have accepted the fact that some sort of machine intelligence may be possible, most people grossly underestimate the difficulties involved. One of the prime lessons of artificial intelligence is the previously unrecognized richness and subtlety of human common sense, and the extent to which it guides our thinking. Nevertheless, by 1990 the western nations will have a wide variety of commercially useful applications. It is not inconceivable then that artificial intelligence programs will be used by the general public at home. What is more, they will be used by many professionals whose decisions affect people's personal lives. Are there

dangers in this prospect, and, if so, can they be avoided?

The man in the street may place too much trust even in today's limited programs. One might almost say that it is the unintelligent tasks that such programs cannot handle. Many of the things that our minds enable us to do are not normally called intelligent, because we can all do them so easily. Everyday abilities like talking, seeing, or realizing friendliness from a facial expression, do not normally need conscious effort. Nor can we say how we do them. But they are far from simple. Indeed, their complexity — and subtlety — was not appreciated until researchers tried to model them on computers.

The activities that involve our common sense present a daunting challenge to artificial intelligence. By contrast, many of the tasks we pay highly specialized professionals to do have proved more tractable. Expert systems can already advise us on some of the recalcitrant problems faced by mathematicians, doctors, genetic engineers, geologists, and chemists. This seeming paradox has surprised researchers, and most members of the public still are not aware of it. The widespread ignorance of this fact can be dangerous, to some degree, for it means that most people lack a reliable sense of which questions current artificial intelligence systems can be expected to handle. It will be difficult to warn people of these deficiencies as future systems achieve more humanlike programs whose limitations will not be so readily apparent to someone interacting with them. There is no hope of developing fifth generation systems unless they can be made more human than today's programs. This will require some basic theoretical advances.

How smart are they?

Tomorrow's computers will need a better grasp of natural language, for example, and a better approximation to common sense thinking. Without natural language they would be useless to the man in the street, who does not want to learn a special programming language, and they would be unable to interpret written texts or reasonably normal conversation. And without something like common sense, they would fall into all manner of absurdities.

A future expert system could appear to have a fairly subtle command of natural language within the subject for which it was designed. Many users might therefore assume that it has a complete command of that language, at least in that subject. Some might even believe it to have a rich command of language in other areas too. These false assumptions could lead to its judgments being given more credit than they are worth.

Suppose the computer uses a familiar English word such as *possible*. The user knows that this word is similar in meaning to a number of others (such as *probable*, *likely*, *conceivable*, and so on), but also knows that it is not precisely equivalent to any of those, for each word has subtly different shades of meaning. Therefore, we should not assume that the words used by the computer, however well chosen in context they appear to be, have been carefully selected in preference to other words carrying rather different implications.

What of common sense? This is needed, for example, when someone has to make guesses about relevant facts. If one of these guesses is incorrect, that new information can be used from then on.

People can cope with the fact that a statement justifiably assumed to be true at one time can later be found to be false.

Understanding limitations

This cannot happen in traditional logic, wherein truths are proved once and for all. And traditional artificial intelligence programs are based on this type of logic. Consequently, much research at present is trying to formalize non-monotonic reasoning, in which truth values can shift from time to time as relevant information reaches the system.

The limitations of artificial intelligence programs as well as their potential must be understood. In particular, it must be realized that every program can in principle be questioned. The reason for this may be surprising. Programs are not objective systems that guarantee the truth, but rather subjective ones that represent the world in ways that may or may not be wholly veridical or reliable.

An artificial intelligence program uses some representation of data, which may be partially false and/or incomplete. It uses rules of inference, which may be faulty in various ways — many will be hunches that are sensible only in certain circumstances. And it employs decision criteria, or values, to select one course of action rather than another and these are essentially problematic. The crucial point, then, is that a program's data, inferences, and values can always in principle be challenged, just as they can when contained in a human mind.

Teaching work

Some work has already been done on developing teaching systems capable

of encouraging this sort of computer literacy. One is the POPLOG system developed at the University of Sussex over the past ten years for teaching arts and humanities students the principles of artificial intelligence programming. It is a user-friendly, interactive programming environment, with a large library of "teach" and "help" files that enables students to learn at their own speed and in their own way. It is also a powerful research tool, since it allows the user to write programs in LISP, PROLOG, and POPIL. It has been recommended by Britain's central research councils as a main tool for current artificial intelligence research.

A system like this can be used to show students fairly quickly that an apparently intelligent program is neither so intelligent as it seems, nor unalterable. For PROLOG helps the student to explore and alter mini-versions of programs. Take ELIZA, for example, a relatively simple program that interacts with its user by way of English sentences. If you type into ELIZA the sentence *My father drove me here*, the program will answer: *Tell me more about your family*, or perhaps: *How do you feel about your father?* If you type in: *I mistrust you*, ELIZA responds with: *Why do you mistrust me?* This seems eerily humanlike. But if you were to type in: *I biggskxz you*, ELIZA will just as happily ask: *Why do you biggskxz me?* In short, the program has no understanding of English. It consists merely of a few simple rules of recognizing a few specific patterns or keywords and responding blindly to them in stereotype ways.

Social implications

No one knows what the effects of artificial intelli-

gence will be on our daily life in the future. Even the long term influence on unemployment is unclear. Some economists see a post-industrial society based on information technology, in which only a few people at opposite ends of the educational spectrum have jobs as we understand the term today, while others forecast a return to full employment after the transition stage.

All agree, however, that the pattern of employment will change, and these changes could lead to a more humane society. Many jobs will be available in the service

and caring sectors of the economy: education, welfare and health care, entertainment, sport, and craft activities. These ways of spending one's time are intrinsically more meaningful and satisfying than many — perhaps most — jobs in industrial societies today. Moreover, even with full employment, working hours will probably be reduced. So people will have more time to spend with their families and their friends than they do now.

Finally, what of the threat that artificial intelligence must deny our individuality and freedom? Many

people fear this dehumanizing influence of computer technology. They would be right to do so if it were true that artificial intelligence can allow no room for these aspects of human psychology. It is not.

Artificial intelligence does not lead to a reductionist psychology — such as behaviourism was, for example. Indeed, it is largely due to the influence of computer based ideas that theoretical psychology now takes the mind, and mental representations or ideas, seriously again. Moreover, research in artificial intelligence en-

courages a new respect for the richness and power of everyday human mental processes. Artificial intelligence can counteract the subtly dehumanizing influence of the natural sciences, in which there is no room for concepts like belief, reason, inference, purpose, and choice.

THE ACCORDION IMAGE SENSOR

Scientists at the Philips Research Laboratories have made a new type of solid-state image sensor. The new sensor has twice as many light-sensitive elements per unit area as previous sensors. This has been achieved without the need of a finer pattern for the electrodes applied to the sensor surface by IC technologies. The improvement is achieved by a new method of distributing the potentials over the electrodes. In this method a row of picture elements (pixels) is located under every two electrodes, whereas four electrodes were previously required for each row. The availability of only two electrodes per picture element makes the transfer of the image information from the 'camera' section to the 'memory' section ('frame transfer') rather more complicated. The potential hills that separate the information coming from the different individual elements are now stretched out one by one and then compressed again, like the bellows of an accordion.

In a solid-state image sensor, and also in a CCD (charge-coupled device) shift register, narrow parallel channels of *n*-type material are located in a layer of *p*-type silicon. On the surface there are linear electrodes, which are perpendicular to these channels. The electrodes

are insulated from each other and from the silicon surface. If the silicon surface is exposed to light — through the electrodes — electrons are released in the silicon. If suitable potentials are applied to the electrodes (Fig. 1a), these electrons will build up charge packets under

the positive electrodes in the *n* channels. In this way, charge is collected during a scanning period, with the size of the charge packets providing a measure of the local illuminance in the image. Next, during the read-out phase, the electrode potentials are varied in

such a way that the potential hills and valleys execute a 'peristaltic' motion (Fig. 1b), which transfers the charge packets from the image section to a storage section. From there they are read out line by line so as to supply the video signal. During the following scan-

ning period, the potential pattern on the electrodes in the image section is shifted by two electrode widths to give the usual television interlacing.

Although three electrodes per cell would be sufficient for transfer of the collected charge, four electrodes per cell are generally used, as indicated in Fig. 1. This provides simpler control and correct interlacing.

If the conventional 3.5- μm technology is used in making a sensor, the cell dimensions will be fairly large. They can be made a little smaller by using a three-layer electrode structure. If this is done, however, the light incident on the sensor at some places must pass through three layers of electrode material (polysilicon) before it is detected. This gives a reduced sensitivity, particularly in the blue part of the spectrum.

The accordion principle

Two electrodes per cell are in principle sufficient for collecting the charge. With this arrangement, however, charge transfer is not as simple as before, so the following technique has been devised. Instead of transferring all of the image information to the storage section at the same time, each charge packet is temporarily spread out in the space beneath two electrodes, and separated by a potential barrier two electrodes wide, beginning at the bottom edge of the image section. The conventional method of charge transfer can then be used, and the image information is 'peeled off' line by line. The temporary 'stretching out' of the information disappears again when the charge packets reach the bottom edge of the storage section, so that in the storage section a row of picture elements again comes beneath two electrodes. All this is

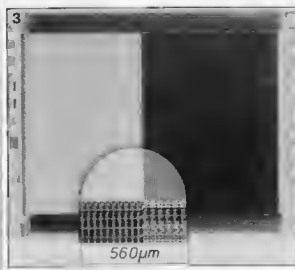
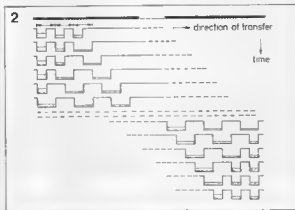
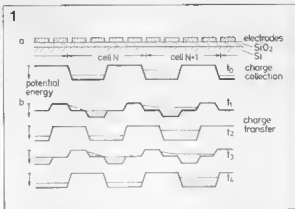

shown schematically in Fig. 2. As the final read-out proceeds line by line at the bottom edge of the storage section, it automatically creates the space required for the renewed stretching out of the charge packets before they are transferred to the bottom edge. In this way much smaller cell dimensions can be achieved with the same

production method, the 3.5- μm technology: a total of 604x588 light-sensitive elements can be located on an area of 38.2 mm². With this method, it is also possible to reduce the area of overlap between the electrodes considerably. If the width of the electrodes is also reduced locally, the sensitivity is improved, particularly in the blue region.

Fig 1 a) At the top is a schematic cross-section of the electrode structure of a solid-state image sensor, in the longitudinal direction through an n-type silicon channel. One cell covers four electrode widths. Below the cross-section, the potential distribution during the recording of a picture is shown. The charge packets in the potential wells are indicated schematically. b) Sequence of potential distributions for transferring the image information (to the right).

Fig 2 Schematic representation of the potential distribution in an accordion image sensor at successive moments during the transfer of the image information from the image section to the storage section. At top left the first information leaves the image section. The picture elements that initially cover two electrode widths are stretched out one by one over four electrodes; the accordion is 'pulled open'. At bottom right the first information arrives at the far end of the storage section. The information for one image point is once again accommodated in a storage element two electrodes wide; the accordion is squeezed shut again.

Fig 3 The accordion image sensor. The image section (dark) and the storage section (light) are at the centre. The electronic circuitry for generating the electrode voltages is shown along the edges. Inset: enlarged view at the transition from image section to storage section.

Fig 3 shows the complete image sensor described here, with part of the picture enlarged. The results described here refer purely to laboratory research; they in no way imply the manufacturing or marketing of new products.

This sixth article in the series deals with the colour extension, which is basically a large amount of extra RAM (Random Access Memory) for the main (monochrome) card. One extension is sufficient for up to sixteen colours on two or four screen pages.

HIGH-RESOLUTION COLOUR GRAPHICS CARD — 6

by P Lavigne &
D Meyer

The colour extension card contains three identical sections, each comprising a 64 Kbyte memory bank, a shift register, RMW circuitry, and colour decoding logic for memory write operations. In theory, any number of extensions could be added to the main card, but in most practical cases one will suffice to provide up to sixteen colours.

Adding an intensity bit

In the very first part of this series, published in the October 1985 issue of *Elektor India* block schematic diagrams of the monochrome and full colour systems were presented in Figures 1a and 1b respectively. For reasons of clarity, Fig. 1b then showed an 8-colour RGB configuration with three memory planes. However, with a completed main card and an extension available, four memory planes in all are at the user's disposal for storage of pixel attributive information. If the fourth bit is used to supply pixel intensity information in addition to the RGB bits already mentioned, sixteen instead of eight pixel colours become available. It will follow that with n memory banks installed, the number of available shades of colour is 2^n .

As already pointed out in previous articles, every dot on the screen corresponds to one bit in the GDF RAM memory. If this bit is at a high logic level, the dot will be dark, whereas a logic low level will light it. As for a pixel, three of these dots (bits) specify its colour; one bit controls the red electron beam inside the monitor picture tube; the second, the green beam; and the third, the



Fig 28 Two connectors and a length of 34-way flat ribbon cable connect extension and main card

originate from the colour extension. A similar procedure goes for reading address XX64, as summarized in Table 12. Note that in this case only bit 0 (Σ 1) is a main card signal, the rest come from IC₁ on the extension card.

Table 12

PIXBUF - XX64 _{hex}									
[READ]									
BY	IN	IN	IN	IN	IN	IN	IN	IN	IN
X	X	X	X	X	X	X	X	X	X

One might perhaps wonder why the double address decoder hardware on the extension card was not replaced by a simple, direct connection of signals Σ , DIN, and WR5 between main card and extension. The answer is that the extra hardware solution effectively avoids the complications of additional wiring in case more extension cards are added.

To conclude this paragraph, Table 13 sums up all necessary address decoding options as available on the extension card.

Construction

Before going into constructional details, it must be reiterated that the colour extension is a threefold copy of the corresponding section on the main card, which emphasizes the fact that due attention must be paid to the construction hints given in part 4 of this series. It is again suggested to follow the procedure of ticking off every step in the construction process only after the necessary functional checks have proved satisfactory (Table 14). To operate the extension card, a properly functioning main card should be available, plus a power supply which is able to cope with the additional current consumption of the extension. In the suggested step by step pro-

cedure, the memory banks are fitted and tested one after another. With two memory banks fitted on the extension and one on the main card, a standard RGB system is available for use. The fourth memory bank is installed if a monitor with intensity modulation input is available. It should be noted, again, that all banks are identical and therefore fully interchangeable. It was only by convention that they were given the names R, G, & I in that order, and the user is free to decide on his own configuration.

Cable connection

Connection of extension card and main card is not effected via the microprocessor bus, but via a short length of 34-way flat ribbon cable terminated in connector K₁, as shown in the photograph on page 49. Figure 28 further shows how the 34-way sockets are fitted to the ribbon cable. On the extension PCB, K₁ is fitted on the PCB soldering side to ensure the shortest possible cable between extension and main card. Earth is deliberately connected at the main card side only.

Components

As a general rule, the remarks as given for the construction of the main card (see part 5) are also relevant to the present extension. As for the choice of dynamic RAMs, it is suggested to consult Table 9 in part 4 to find usable types. As with the main card, it is best not to use IC sockets; instead, solder all RAMs direct onto the PCB. Resistors R₈...R₃₁ are preferably fitted as 8-resistor networks, but this is not

28

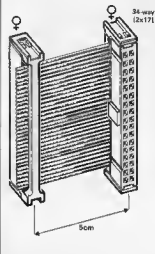

obligatory. The problem with supply decoupling capacitors C₃...C₃₅ is the same as with that of the ones fitted on the main card; they are to be soldered direct onto the IC pins 8 and 16 at the PCB soldering side, and their earth leads must be as short as possible.

It is a rather delicate matter to fit RAS series resistors R₈...R₃₁ and their associated wires to the RAS inputs of the next two memory banks. Component mounting plan Fig. 31b shows that these resistors have track connections to pins 4 of IC₃₁, IC₃₂, and wire connections from there to the other two memory banks. The wires are connected direct to the resistor leads, preferably using a wire wrap device, before carefully joining wire end and lead with solder. The resistor leads are then bent and soldered into place. The connecting pieces of wire are straightened and connected to eight soldering pins at pins 4 of the relevant ICs in the next memory bank (IC₃₁...IC₃₂), which also require soldering pins (Fig. 29). These sixteen (8 x 2) pieces of wire ought to be fitted with the utmost care and precision to avoid short circuits and resultant malfunction of the card.

Wire links

Points A...K, see Fig. 27, must be fitted as wire links or jumpers on the extension PCB according to the straight lines in the circuit diagram. The dotted lines represent the links as required for a second or third extension card.

Link L or M is fitted to suit the RGB monitor bandwidth. In the third part of this series (Elektor Electronics,

Photograph 1 Suggested front panel construction for the graphics system TTL level outputs. The left-hand 19 inch panel holds the I (monochrome), SYNC and SYNC output sockets the right-hand panel holds outputs R, G, B, and I for full colour applications

Table 13

links	address lines	-						decoded			
		A3	A2	A1	A0	address					
B - 2	A2 · E3	0	1	0	0	0	0	4			
C - 1	A3 · E2								0	1	5
									1	0	6
				1	1			7			
B · 1	A3 · E3	1	0	0	0	0	0	8			
C · 2	A2 · E2								0	1	9
									1	0	A
				1	1			B			
A · 1, B - 3	A3 · E3	0	0	0	0	0	0	0			
C - 2	A2 · E2								0	1	1
									1	0	2
				1	1			3			
A - 1, C - 3	A3 · E2	1	1	0	0	0	0	C			
B - 2	A2 · E3								0	1	D
									1	0	E
				1	1			F			

December 1985), Fig. 17 showed how the video output buffers were gated with HCK (system clock) to improve energy distribution between adjacent and isolated lighted dots. The same arrangement is used for output gates $N_{17} \dots N_{19}$ on the colour extension card when link L is fitted. This results in a better defined picture on low-quality monitors, but has the disadvantage of doubling the video bandwidth. Now that colour and intensity modulation have been added, it would seem desirable to make HCK gate control optional; when link M is fitted, the gates will function as output buffers to the preceding shift registers. Total video bandwidth is reduced to 6...7 MHz with link M installed, whereas with link L the full 12...14 MHz bandwidth of the GDP is present at the outputs. To choose between the L or M option, simply try out the effect of both on the available monitor.

As the reduced bandwidth option was not foreseen on the main card, it will have to be slightly modified for this purpose. Cut off pin 12 of IC₂₀ on the main card, but leave a sufficient pin length to solder a small wire close to the IC body. Connect the other wire end to pin 7 of the IC. Note that link M and the modification with IC₂₀ must only be fitted if a marked improvement in picture quality is thus obtained. The normal configuration, however, remains link L.

The outputs

The VIDI and CSYNC (or CSYNC) signals are available at main card output connector K₁, but they also appear on the extension card for efficient combination with VIDR, VIDG, and VIDB into a single 6-way cable for connection to the RGB(I) monitor. As these are all TTL level signals, a common type of cable may be used, provided it is not too long. A practical suggestion for output signal connection is shown in Photograph 1; the extension card has been equipped with a front panel to hold a number of inexpensive phono sockets. It is also possible to use a 5- or 6-way DIN socket, or an 8-pin EIA video socket (Fig. 32). However, these last two socket types lack a certain flexibility as compared to the simple and robust phono type, which enables the user to easily interchange the R, G, B, and I signals for colour effect experiments.

If a SCART compatible monitor is used, it is necessary to use the SCART adapter, as featured in *Elector India*, October 1985.

Capacitors

As already noted, most capacitors are to be fitted onto the PCB track side, as close as possible to the supply voltage pins of all dynamic RAMs. This mounting method is essential, considering the system clock speed of 12 or 14 MHz. As for the shift registers (IC₁₂, IC₁₃, IC₁₄), it has been found that they also greatly benefit from the addition of 0.01 μF supply decoupling capacitors. For this purpose, use miniature ceramic capacitors. With this decoupling, impeccable video signals are obtained, whilst digital spikes on the power supply lines are reduced to a minimum.

Colour combinations summary

All possible combinations of basic colours red (R), green (G), and blue (B) are listed in Table 15, together with the intensity (I) bit, which specifies colour saturation. Note that R, G, and B are in negative logic, the intensity bit in positive logic.

Table 15.

I	R	G	B	code	colour
0	0	0	0	0	off white
0	0	0	1	1	pale purple
0	0	1	0	2	pale magenta
0	0	1	1	3	dark blue
0	1	0	0	4	semi-orange
0	1	0	1	5	dark green
0	1	1	0	6	dark red
0	1	1	1	7	black
1	0	0	0	8	bright white
1	0	0	1	9	bright purple
1	0	1	0	10	bright magenta
1	0	1	1	11	bright blue
1	1	0	0	12	bright yellow
1	1	0	1	13	bright green
1	1	1	0	14	bright red
1	1	1	1	15	dark gray

Note that if the intensity bit were also active-low, colours 8...15 would become 8...15 and vice versa.

As the video interpreter fully supports colour, it is necessary to establish the order of memory banks in relation to the primary colour each of them is to obtain. To obtain the colours as listed in Table 15, the following convention is used: plane I on the main card becomes plane R; extension card plane R becomes plane G; extension card plane G becomes plane B; and, finally, extension card plane B becomes plane I, if required.

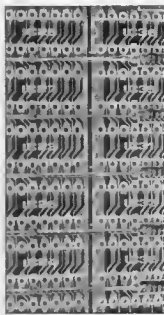
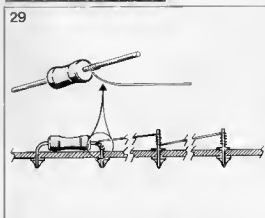
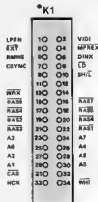

Fig. 29 The photograph and drawing show how RAS resistors $R_{18} \dots R_{24}$ and associated signal distribution wires are best fitted onto the PCB. Watch out for any short circuits at pins 8 and 9 of IC₁₁, IC₁₂, caused by the resistor leads



30

* main from PCB soldering side



85140 30

Fig. 30 Pin assignment of connector K₁ is of course identical with the corresponding main card connector, but here it is seen from the PCB soldering side.

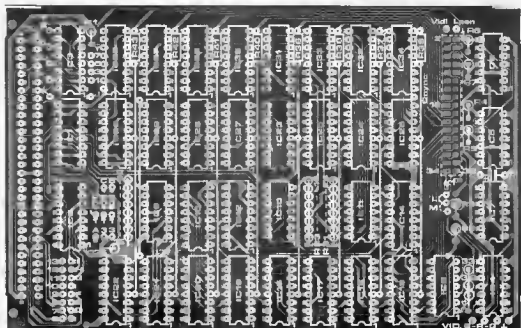
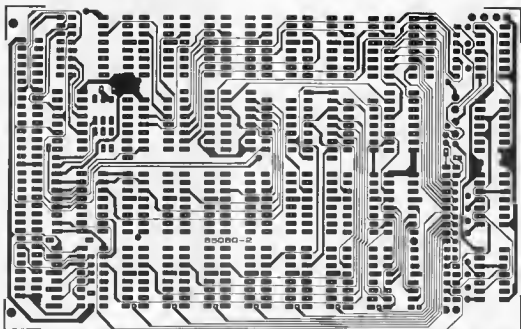

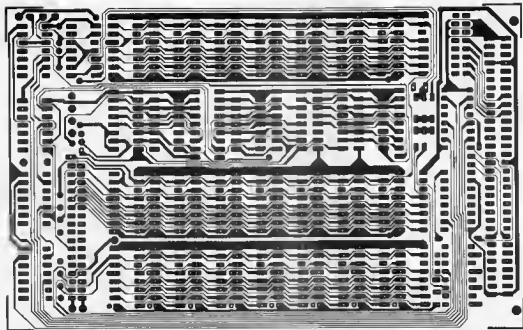

Table 14.

tick	ICs	action(s)
	none	carefully check the empty board visually and electrically
	none	mount completed front panel
	none	fit 64-way connector, wire links A - K, soldering pins for RGB, VIDI, and LPEN
	none	fit link L/M, connector K1 (soldering side!), wire link between IC21 and IC37
	none	fit resistors R34 - R43
	none	fit capacitor C4 between pins 1a/c and 4a/c of the 64-way connector, a terminal to 1a/c
	none	fit R34 + two soldering pins + wires (see text)
	none	fit R35 + two soldering pins + wires (see text)
	none	fit R37 +
	none	fit R42 + two soldering pins + wires (see text)
	none	check R34 - R42 with an ohmmeter
	IC1, IC2, IC3	plug extension and main card onto the bus; connect K1 cable; check supply voltage and address decoder; writing data to XX64 must cause logic output changes at the ICs outputs
	IC4 - IC14 (+ C1)	check presence of signals SH/L, HCK, RAS, CAS. Presence of the extension may in no way disturb proper operation of the main card
	IC14 - IC22	fit capacitors C5... C18 direct onto IC supply pins at PCB soldering side. Check supply voltage and current consumption. Connect main card VIDI output to RGB monitor R input and extension card output R to RGB monitor G input. Earth monitor B input. XX64 00 XX56 : 00 101, 02, or 03 for tuning the page) XX51 03 XX50 0C (screen becomes yellow (red + green) XX64 0f XX50 : 0C screen becomes green (DIS = 1; DINRS = 0) XX64 02 XX50 0C screen becomes red (DIS = 0, DINRS = 1) XX64 03 XX50 0C screen becomes black (DIS = DINRS = 1)
	IC22 - IC30	fit capacitors C11 - C18 direct onto IC supply pins at PCB soldering side. Check supply voltage and current consumption. Follow write procedure as above with subsequent bytes 00 - 07 at XX64, after having connected outputs VIDI, VIDR, and VIDG to monitor RGB inputs. With each write instruction, the screen colour must change as indicated in Table 15.
	IC31 - IC40	fit capacitors C11 - C24 as with the preceding memory banks. Connect VIDB to B input of monitor. Follow write procedure as above with successive bytes 00 - 0F at XX64. If necessary, add 100 nF supply decoupling capacitors to supply pins of IC12 - IC14 and IC4.

Fig. 31c Component side of the through-plated colour extension PCB

32

EIA video connector



Pin designation

1. Intensity
2. Red
3. Green
4. Blue
5. Earth (RG2)
6. Earth (RG1)
7. Composite sync or horizontal sync (HS)
8. Vertical sync (VS)

DESIGNING A CLOSED LOUDSPEAKER BOX

There are currently two loudspeaker systems: closed or total (US) box, sometimes unfortunately referred to as infinite baffle, and the reflex box. The latter is typified by a hole in its front panel (other than the drive unit apertures), while the closed box is exactly what its name implies. Of the two, the closed box is

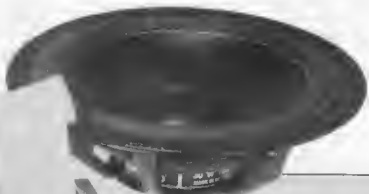

nowadays the preferred system with reputable manufacturers and DIY enthusiasts alike. Because of that, this article will describe briefly what is involved in the design of a closed box as far as bass loading is concerned. Interested readers may note that the design of an excellent cross-over network was featured in the January 1988 issue of *Elektor India*.

It should be noted that the design and construction of a loudspeaker enclosure are well within the competence of most of us and that if the considerations given in this article are observed, the results will approach those of proprietary units.

The net volume of the enclosure should ideally be an optimum for a given drive unit but, unfortunately,

this is not always practicable, nor does it necessarily result in a performance that satisfies all personal tastes and preferences. It is, none the less, possible to arrive at an acceptable compromise in virtually every individual case

The drive unit

It is important before buying the drive unit to consider the following carefully because this unit will largely determine what sort of enclosure is needed.

Knowing the following three characteristics of the drive unit is essential for the computation of an optimum enclosure: (a) the resonant frequency, f_s , in

free air; (b) the Q factor, Q_s , of the resonant frequency; and the suspension compliance, V_{as} , in litres. All reputable manufacturers publish these characteristics.

Q factor of the system

The frequency response of a closed-box system is a second-order, i.e. 12 dB per octave, high-pass filter function. The Q value of the loudspeaker system, Q_c , determines the shape of the response characteristic. Fig. 1 gives the characteristics for a number of loudspeaker systems with different Q_c values. It shows that the optimum second-order

Butterworth curve is obtained at a Q_c value of $1/\sqrt{2}$, i.e. 0.707. Values between 0.5 and 1.0 are perfectly acceptable, but those above 1.0 result in a distinct peak and lead to poor step response, which is definitely not acceptable in hi-fi systems. Fig. 2 illustrates the differences in step response for varying values of Q_c .

The arithmetic

It is safe to start the computations with a Q_c value of 0.7; when this results in unacceptable values for the resonant frequency, f_s , of the system, or volume of the box, V_s , other values of Q_c may be tried. The resonant frequency of the loudspeaker system is

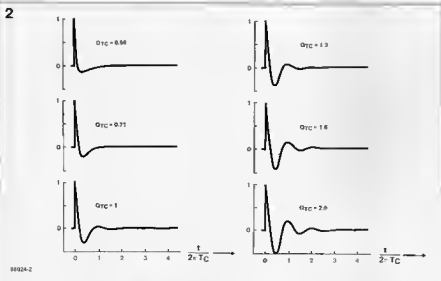
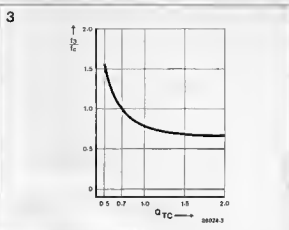
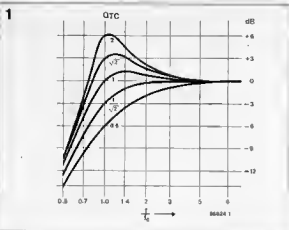

Fig 1. Effect of the Q_{TC} value on the frequency response of a loudspeaker system. Designers generally consider a value of $1/\sqrt{2} = 0.707$ as ideal.

Fig 2. Normalized step response of the closed-box system. The higher the Q_{TC} , the poorer the step response: a good reason for not adopting a Q_{TC} value above 1.0.

Fig 3. The relation between the resonant frequency of the closed box, f_c , and the -3 dB, f_b , point depends on the Q_{TC} value. At a Q_{TC} value of 0.7, $f_b = f_c$.

calculated first:

$$f_c = f_c(Q_{TC}/Q_{TS}) \quad (1)$$

At a Q_{TC} of 0.7, the resonant frequency of the system is also the -3 dB point, f_b , of the box. Other values of Q_{TC} cause a shift as shown in Fig. 3. For instance, at a value of 0.5, f_b is one and a half times the value of f_c . If, in formula (1), the values of Q_{TS} and f_c are stated by the manufacturer to be 0.35 and 30 Hz respectively,

$$f_c = 30(0.7/0.35) = 60 \text{ Hz}$$

The volume of the box is calculated from:

$$V_b = V_{AS}(f_c^2/f_c^2 - 1) \quad (2)$$

If, for instance, the manufacturer's stated value of V_{AS} is 0.09 m^3 , i.e., 90 litres,

the net volume of the enclosure is

$$V_b = 90(60^2/30^2 - 1) = 30 \text{ litres.}$$

Summarizing: If a drive unit with $f_c = 30$ Hz; $Q_{TS} = 0.35$; and $V_{AS} = 0.09 \text{ m}^3$ is built into a 0.03 m^3 enclosure, the loudspeaker system will have a resonant frequency of 60 Hz at the ideal Q_{TC} value of 0.7.

If these results are not acceptable, one of the parameters may be changed. It is clear from the foregoing, however, that Q_{TC} , f_c , and V_b are interdependent: change one, and you change all three.

If, for example, the system resonant frequency of 60 Hz is considered too high, insert the desired value, say, 45 Hz, into formula (1) and calculate Q_{TC}

from a rehash of the formula.

$$Q_{TC} = Q_{TS} f_c / f_c \\ = 0.35 \times 1.5 = 0.525$$

Then, insert the new value of $f_c = 45$ Hz into formula (2) and calculate V_b :

$$V_b = 90(45^2/30^2 - 1) \\ = 90(1.25 - 1) = 22.5 \text{ litres}$$

If, however, an enclosure volume of 30 litres was considered rather high, Q_{TC} could be taken somewhat higher. It will be found that for the same loudspeaker parameters, and taking $Q_{TC} = 1$, the system resonant frequency, f_c , will be 86 Hz, and the net volume of the enclosure, V_b , will be 12.5 litres.

As a rule of thumb: the larger the enclosure, the lower the Q and the resonant frequency. A (too) small box will result in a high system Q and a high resonant frequency. JR

RF CIRCUIT DESIGN

This month we commence a short series of articles on the design of RF circuits. Each of the articles will merely provide a framework and not necessarily a complete design of the relevant circuit.

Test oscillator

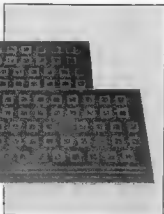

Fig 1 The copper-clad universal RF board Type 85000 has fifty-seven islands and three isolated tracks for supply voltage or control voltage — such as AGC — lines

This first article deals with a virtually indispensable unit in RF design: a simple signal generator. This unit provides a signal at a certain frequency and amplitude, and may be frequency- or amplitude-modulated. It is intended to cover a frequency range of 2 — 150 MHz in a number of bands.

Universal RF board

The Type 85000 is an unpierced copper-clad board

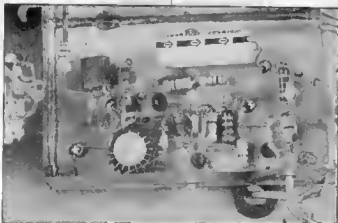

Fig 2 Example of a voltage-controlled oscillator constructed on a copper-clad board

with fifty-seven isolated islands and three isolated tracks. It is particularly suited to RF circuits because of the large earth plane, and enables the connections of all components to be kept really short — a prerequisite in RF design. Examples of the board proper and of a voltage-controlled oscillator constructed on a copper-clad board are shown in the photographs in Figures 1 and 2 respectively.

Block diagram

The block diagram in Fig. 3 shows that the test oscillator consists of three separate sections: the oscillator; amplitude control; and output buffer. The oscillator is based on a MOSFET, whose mutual conductance, g_m , and consequently the amplitude of its output signal, is controlled by a direct voltage on gate 2.

The amplitude control section monitors the oscillator output and controls gate 2 of the MOSFET accordingly, so that a reasonably constant level oscillator signal is obtained. This arrangement has the advantage that it enables the oscillator to work over a fairly wide frequency range.

The buffer section provides an output impedance of 80 ohms.

Circuit description

The oscillator — see Fig. 2 — is designed around T₁; its frequency-determining components are L₁ and varactors D₁ and D₂. These variable-capacitance diodes are controlled by P₁: a high voltage across them causes a small capacitance, and vice versa. The frequency of an LC oscillator is given by

$$f = 1/2\pi\sqrt{LC} \quad \text{[Hz]} \quad (1)$$

where f is the frequency of the oscillator, L is the inductance in henries (H), and C is the total capacitance of the two varactors in series in farads (F).

The ratio between the lowest and the highest oscillator frequency, f_1 and f_2 respectively, depends on the square root of the ratio between the maximum and minimum capacitance, C_2 and C_1 , respectively, of the varactors:

$$f_1/f_2 = \sqrt{C_2/C_1} \quad (2)$$

The maximum capacitance of the Type BB106 varactor is about five times the minimum capacitance for a reverse bias voltage of 3 of 25 V, so that the frequency ratio is roughly 2.236, or rather more than an octave. The highest attainable frequency is around 300 MHz, but this depends, of course, also on the value of L₁.

The series combination L₁-L₂-L₃ is intended as a sort of wide-band choke. The inductance of L₁ (100 mH) is rather too large for high frequencies, because the reactance at those frequencies amounts to a few kilohms owing to parasitic capacitances. Lower inductances are, therefore, used for the higher frequencies: L₂ and L₃. Inductor L₂ is only of use at frequencies above 50 MHz: if the oscillator is not required to work on these frequencies, this coil may be omitted and replaced by a wire link.

3

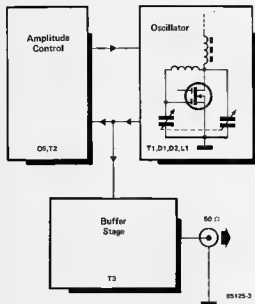

The signal at gate 1 of the oscillator is rectified by D_1 and smoothed by R_1-C_1 . As soon as the resulting direct voltage rises above 600 mV, the transistor tends to conduct harder, which causes the potential at gate 2, and therefore the oscillator output, to drop. This regulation is necessary if the oscillator is to work over a relatively wide frequency range. Also, without regulation, the output level would vary greatly with tuning; in the present circuit, the output level variation is held within 10 dB, i.e., a ratio of about 1:3.

The oscillator signal is applied via capacitive divider C_7-C_8 to transistor T_3 which is connected as a source follower. The mutual conductance, g_m , of this FET is about 20 mS, so that, since

$$Z_o = 1/g_m \quad [Q] \quad (3)$$

the output impedance, Z_o , is 50 ohms.

Fig. 3. Block diagram of the RF test oscillator

Mutual conductance is the ratio of the change in output current to the change in input voltage when the output voltage is held constant. It is measured in siemens (S), which replaced the mho (reciprocal of ohm) some time ago.

Fig. 4. Circuit diagram of the RF test oscillator

4

BF900; BF905; BF907; BF961; BF981

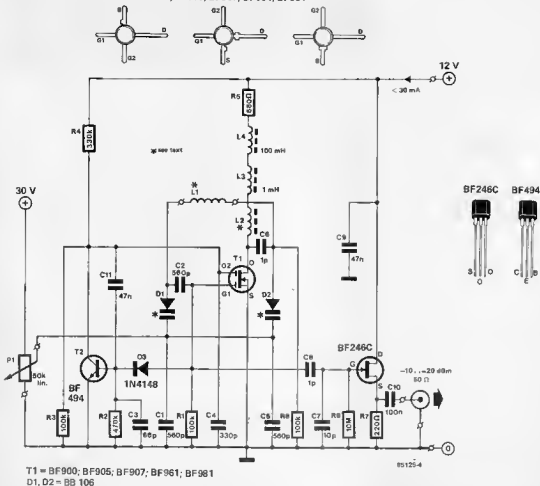

T1 = BF900; BF905; BF907; BF961; BF981
D1, D2 = BB 106



Fig 5 Suggested component layout of the RF test oscillator

Parts list

Resistors

R₁, R₂, R₄ = 100k
 R₃ = 470k
 R₄ = 330k
 R₅ = 680Ω
 R₆ = 10M
 R₇ = 220Ω
 P₁ = 50k linear preset

Capacitors

C₁, C₂, C₃ = 560p
 C₄ = 86p
 C₅ = 330p
 C₆, C₇ = 1p
 C₈ = 10p
 C₉, C₁₀ = 47n
 C₁₁ = 100n

Inductors

L₁ = 0.1 .10mH (see text)
 L₂ = 5 turns 0.3 mm dia (30 SWG) enamelled copper wire on ferrite bead 3 × 3 mm
 L₃ = 1mH choke
 L₄ = 100mH choke

Semiconductors

T₁ = BF900 or BF905 or BF907 or BF961 or BF981
 T₂ = BF484
 T₃ = BF246C
 D₁, D₂ = BB106 (see text)
 D₃ = 1N4148

Universal RF board
 Type 85000

Fig 6 Circuit of a possible 50-ohm one-step attenuator. The resistor values in the accompanying table are calculated in a practical circuit, the nearest standard values should be used

Frequency range

If varactors Type BB106 are used, the oscillator can be tuned over a frequency range of one octave, i.e., the maximum frequency is about twice the minimum frequency. To cover a frequency range of, say, 2 MHz to 32 MHz (four octaves) four different coils are required for the L₁ position. Since it is not really possible to use a large tapped coil and a range switch — because the resulting stray capacitances would cause unreliable and unstable operation — separate plug-in coils must be used for L₁. At the highest frequencies — above about 150 MHz — the coil should be air-cored; below 150 MHz, it needs to be wound on a dust-iron toroid. Some examples of suitable coils for frequency ranges as stated are:

- 150-300 MHz: 50 mm enamelled copper wire, SWG20 (1 mm dia.), one turn;
- 75-150 MHz: 9 turns 24 SWG (0.6 mm dia.) enamelled copper wire on a Type T50/12 toroid;
- 7.5-15.0 MHz: 70 turns SWG 30 (0.3 mm dia.) on a Type T50/2 toroid.

Although the Type BB106 varactor can be used right across the frequency range, a Type BB105 is better if most of the work is carried out above 100 MHz, while a Type KV1226 is preferable below 20 MHz.

Modulation

Frequency-modulating the oscillator signal is achieved by applying the modulating voltage to the wiper of tuning potentiometer P₁ via a series resistor and coupling capacitor. It is possible to add a potentiometer for adjusting the level of the modulating voltage, i.e. the frequency deviation. Amplitude modulation could be arranged by injecting the modulating signal into gate 2 of the oscillator. This is, however, not a satisfactory method because the internal capacitances of the MOSFET vary with the modulating voltage, resulting in not only amplitude modulation, but also frequency modulation, of the oscillator signal. It is, therefore, better to modulate with the aid of an additional MOSFET connected between the oscillator and the buffer.

Output attenuator

It is very useful in many applications if the output signal can be attenuated in suitable steps. A suitable circuit for a one-step attenuator is shown in

5

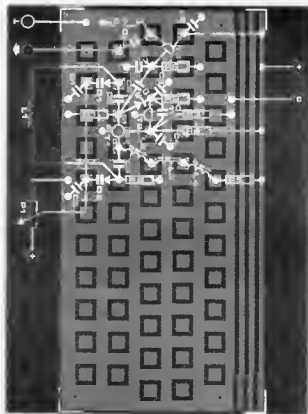

6

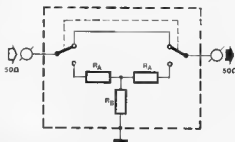

Attenuation	R _A	R _B
2 dB	5.7 Ω	215.2 Ω
4 dB	11.3 Ω	104.8 Ω
8 dB	21.5 Ω	47.3 Ω
10 dB	26 Ω	35 Ω
20 dB	41 Ω	10 Ω

85129-6

Fig. 6. Several of these circuits may be connected in series to obtain switch-selected stepped attenuations of, say, 2 dB, 4 dB, 8 dB, and so on. Note, however, that the greater the attenuation, the more attention should be paid to screening and decoupling. Any signal 'leaks' at the output at low levels spoil the ac-

curacy of the attenuator. The table accompanying Fig. 6 gives calculated values for the attenuator resistors; in practice, the nearest standard values in the E12 or E24 series should be used. Note that wirewound resistors should never be used in RF circuits owing to their high self-inductance. JB/BL

Digi-Course II

(Chapter - 4)

The internal working of the logic gates inside a Flipflop is quite complex, as we have seen in the last chapter. However, there is nothing to worry about, because once all this complex circuitry is put inside an IC, we are concerned with only the external connections. These external connections, and the logical behaviour of the Flipflop is all that we need to know, when we are using the Flipflop.

We have two sockets provided on our Digilex board for the Flipflop ICs 74LS76. These are marked IC 6 and IC 7. These ICs are quite inexpensive and you can obtain them from any good electronic components shop. Each of these ICs contains two Flipflops and thus we have four universal Flipflops available for experiments.

1

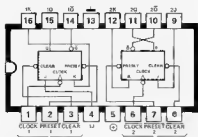

For studying the properties of these Flipflops we can connect the circuit shown in figure 2. A Flipflop made of two NAND gates is used as the input to the clock (CLK) pin of the Flipflop FF1 (half of IC 6). The NAND Flipflop is used for obtaining noise free clock pulses. These pulses are indicated by the output indicator LED C. Terminals S and R are alternately connected to the ground line to generate the clock pulses.

2

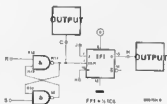

The supply pins of IC 6 and IC 7 are not connected to \oplus and \ominus on the Digilex board. They need external connection to these supply lines. Output indicator H is connected to the pin Q of the JK Flipflop from IC 6 to show the state of the JK Flipflop. Pins J and K are used to select the J/K combination at the input of FF1.

When Pin R is momentarily connected to Ground line it gives a 0/1 combination at the input R/S of the NAND Flipflop and sets that Flipflop. This is indicated by the glowing LED indicator C. This high level appears at the clock input of FF1. Now you can connect the pins J and K to get either a 0/1 or a 1/0 combination. During this, the Flipflop FF1 is unaffected because it has a '1' on its clock input. After setting the J/K combination to 0/1 or 1/0, touch the S terminal to the Ground line. This resets the NAND Flipflop and its output becomes '0', (observe the LED C). This negative going edge at the clock input triggers the Flipflop FF1 and it latches the 0/1 or 1/0 combination which was present on the J/K inputs at that moment.

In short, we can describe the above operation as follows:

The Flipflop FF1 latches the input combination J/K into the output Q/Q-bar on the negative going edge at the clock input.

We have just seen the effect of setting up J/K either as 0/1 or 1/0. Now let us find out what happens when J/K is D/D or 1/1. For this, first reset the NAND Flipflop. Then set the J/K inputs as 0/0 and clear the Flipflop FF1 by connecting the CLEAR pin to ground momentarily. This gives a 0/1 at Q/Q-bar output. If the NAND Flipflop is now set and reset using the terminals R & S, it will produce a clock pulse at the clock input of FF1. Note that the Flipflop FF1 remains unaffected and retains its state.

Repeat the same experiment with J/K = 1/1. This time, the Flipflop FF1 changes its state on every negative going edge at its clock input. Figure 3 shows the timing diagram of levels at the clock input and the outputs Q and Q-bar of the Flipflop FF1 (Figure 3).

3

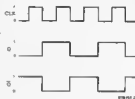

If you observe the relation between the pulses available at the outputs Q and Q-bar and the input clock pulses, a very interesting point can be noted. The input pulses are exactly halved in the output, or in other words, we have just covered a circuit which is a 2:1 divider. It is quite obvious that if we feed the output of the first Flipflop to the clock input of another Flipflop and keep its inputs J/K as 1/1 again, we will have a 4:1 divider. Using all the four Flipflops available to us we can generate a divider chain with 2:1, 4:1, 8:1, and 16:1 divided outputs. This arrangement is shown in figure 4. Note that all the four CLEAR inputs are connected together. This can be used to clear all four Flipflops before we start giving the input clock.

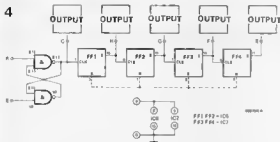

The timing diagram for this circuit is given below, in figure 5.

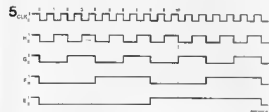

As we have a chain of dividers which divide the incoming pulses by two at each stage, the ratios we obtain are all binary values. Though this is quite natural in digital technology, it becomes a bit inconvenient in actual practice when we work with the decimal system. A decimal divider would be of much more value than a binary divider when we are working with the decimal system. This is possible if we take the help of the CLEAR inputs we have connected together.

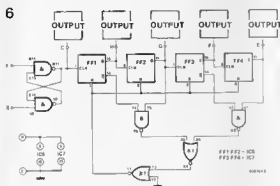
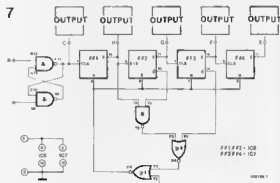

Figure 6 given above, shows a modified circuit. This has a few additional NAND and NOR gates to detect when the tenth pulse comes at the input. This moment is used to clear all four Flipflops simultaneously, so that the counting starts all over again. The LED indicator now glows once for every ten pulses at the clock input of FF1.

The additional circuit detects the condition when FF1 and FF3 are reset and FF2 and FF4 are set. At this point, the output of the NOR gate (at Y1) becomes '0' and clears all four Flipflops.

This arrangement has one disadvantage, which can be clearly seen from figure 5. The LED 'E' glows during 9th and 10th pulses and remains off during the first eight pulses. This defect called non symmetrical duty cycle can be rectified by modifying the circuit again as shown in figure 7.



Here the chain is rearranged into a 5:1 divider followed by a 2:1 divider. Now the LED 'E' remains off for five input pulses. This gives us a 10:1 divider with symmetrical duty cycle.

The Digilex-PCB is now available!

The Digilex-PCB is made from best quality Glass-Epoxy laminate and the tracks are bright tin plated, the track side is also soldermasked after plating. Block schematic layout of components and terminals is printed on the component side.

Price:

Rs. 85.00 + Maharashtra Sales Tax.

Delivery charges extra! Rs. 6.00

Send full amount by DD/MO/PO.

Available from:

precious[®]

ELECTRONICS CORPORATION

11, KILN LANE, OFF LAMINGTON RD.

BOMBAY - 400 007.

In our August/September 1985 issue, we had described a simple circuit for a 4.5 V Battery Eliminator. Although very useful for a beginner, a fixed voltage source may cause inconvenience when an experiment you are doing needs certain other value of supply voltage.

A variable voltage power supply circuit is described here. The voltage at the output of this supply can be adjusted smoothly at any desired value between 0 to 15V. The maximum output current is 0.5A. The left half of the circuit shown in figure 1 is similar to the 4.5 V battery eliminator circuit, except for the transformer. The transformer has a secondary voltage of 18 V in this case.

The bridge rectifier B1 is followed by an electrolytic capacitor C1, called the filter capacitor. To understand the function of the filter capacitor, we must once again go back to our notes on alternating currents and voltages.

AC Voltage Sine-Wave

The AC voltage available at the mains socket changes its polarity one hundred times every second. This change does not take place abruptly. The change in voltage level follows a sine wave as illustrated in figure 2. The periodic pattern consists of alternate positive and negative half waves. The sine wave shown in figure 2 is present at the primary input of the transformer. Figure 3 shows the sine wave present at the secondary output of the transformer and the wave form present at the output of the bridge rectifier. The sine wave shown in figure 3a is proportionately smaller in voltage levels compared to the one shown in figure 2.

The waveform shown in figure 3b is similar to that in figure 3a except for the

Variable Power Supply

fact that it consists of all positive half cycles. This inversion of the negative half cycles takes place due to the construction of the bridge rectifier. It allows the positive half wave to pass through to the output directly, but it reverses the polarity of the negative half wave as it passes through the bridge rectifier. The alternating voltage at the input of the bridge is thus converted to a pulsating direct voltage. As this voltage consists of 100 such half waves per second, it is not suitable for an electronic apparatus which requires a steady level of DC voltage. Such a rectified voltage will produce a horrible hum in the loudspeakers if we operate an amplifier from this voltage.

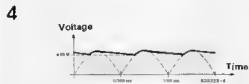
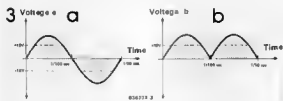
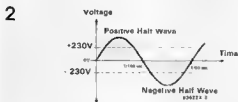
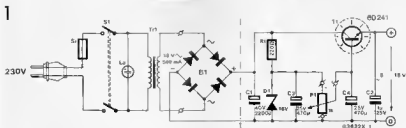

Figure 1. Complete circuit diagram of the variable power supply.

Figure 2. The sine wave of the alternating voltage.

Figure 3: Voltage at the input (a) and output (b) of the bridge rectifier.

Figure 4. The voltage across the filter capacitor C1.

Figure 5. Reference voltage source using a zener diode.

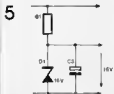

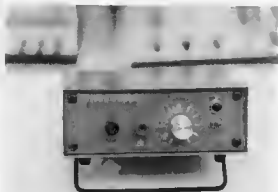

Filter Capacitor

The filter capacitor C1 comes to our help in reducing the voltage variation caused by these half waves. During the very first half wave, the electrolytic capacitor C1 gets charged to the voltage supplied by the bridge rectifier. When the bridge output starts falling along the sine wave, the capacitor supplies some of its stored charge. Thus the voltage at the output of the bridge does not fall as rapidly as it would have done in absence of the filter capacitor C1. The voltage pattern across the capacitor C1 is shown in figure 4. The small fluctuation that still exists in the output voltage across C1 is called the ripple voltage. Transistor T1 further reduces this ripple voltage.

The part of the circuit that follows C1 is used to obtain variable voltage at the output across capacitor C2. The voltage supplied at the collector of the transistor T1 is always the same as that across the

capacitor C1. As we require an adjustable voltage at the emitter, the collector-emitter junction must take up the excess voltage. This is achieved by using the property of the base-emitter junction. The base-emitter voltage remains fixed at 0.6 Volts when the base-emitter junction is forced into conduction. Using this physical property of the base-emitter junction we can clearly see that the voltage at the emitter with respect to ground will depend on the base voltage with respect to ground (see figure 7). If we can adjust the base voltage, the output voltage at the emitter will automatically change.

This means that we must have an adjustable voltage at the base of transistor T1. To achieve this, a potentiometer P1 is used along with two more filter capacitors C3 and C4. Zener diode D1 provides a stable reference voltage across the potentiometer P1 (see figure 5 and 6.) A 16 V

zener is used in this case, so that a stable 16 V DC is available across the potentiometer P1. The sliding contact of the potentiometer can take voltages from 0 to 16V depending on its position. Now once again referring to the figure 7 we can see that the output voltage U_a will be less than the voltage U_b at the sliding contact of the potentiometer by 0.6V. The relation between the two voltages is as follows:

$$U_a = (U_b - 0.6) V$$

The output voltage will thus be adjustable by changing the setting of the potentiometer. This relation also explains why we need a zener voltage of 16 V to achieve a 0 to 15V range at the output. (To be precise, the output will be 0 to 15.4V). When U_b is less than or equal to 0.6V the base-emitter junction will not conduct and the transistor T1 will be cut off. There will be no output voltage available in this case.

Construction Details

The circuit described above can be constructed as per the component layout shown in figure 8. Follow the usual sequence for soldering various components. First the jumper wires, then resistors, condensers and semiconductors. Except for resistors, other components in this circuit are polarised. They must be mounted with the correct polarity to avoid any undesired damage.

The plus pole of the Zener diode coincides with the ring printed on the body. Since the transistor conducts the entire load current through its collector-emitter it will become hot during operation. A cooling fan or heat sink must be provided for the transistor T1 for proper heat dissipation. The heat sink can be fixed on to the transistor body with a nut and screw. As the heat sink is not very

Figure 6 Potentiometer P1 used as a potential divider to obtain voltages from 0 to 16 V

Figure 7 How the transistor T1 functions. Figure 8 Component layout of the variable voltage power supply.

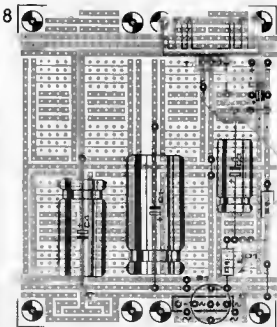
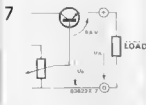
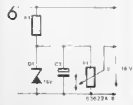

Table 1

Voltage across	Value	Gives information on
Transformer primary	230V AC	socket, plug, cable, fuse and transformer
Transformer secondary	18V AC (Approx)	Transformer
C1	25V DC (Approx)	B1 C1
D1	16V DC	R1 D1 P1 C3
C4	0 to 16V DC (Depending on potentiometer setting)	P1, C4 T1
Output	0 to 15 V DC (Depending on potentiometer setting)	T1, C2

heavy, it can be supported directly by the soldered transistor itself. Note that the heat sink fixed onto the transistor is connected to the collector of the transistor and should not be grounded.

Wiring diagram for other components like potentiometer, sockets, transformer, switch, fuse end indicator lamp can be seen in figure 1. While assembling the power supply in its casing, the rules to be observed with equipment connected to AC mains voltage must be strictly followed. These rules have been earlier discussed on page 766 of the July 1985 issue of *Elektor India*.

Figure 9 shows the completed assembly of the power supply. A mains input socket with a built-in fuse holder is used in the prototype as shown in figure 10.

After the assembly is complete, you can give your power supply the 'Smoke Test', before fixing the top cover of the casing. Connect the mains cord and switch on the power. If nothing smokes, burns, cracks, gives foul smell or gives any disaster signals, the first test is passed.

For the second test, connect a multimeter at the output and check if the potentiometer is able to adjust the output voltage between 0 to 15V. If everything is in order, the casing can be closed. If

the circuit does not work properly, check all the voltages given in table 1 to locate the faulty components or wrong connections. If the measured voltage for any component deviates considerably from the specified value, check more carefully in that area for wrong connections. If all connections are correct, that particular component may be defective.

While purchasing the components, care must be taken to obtain the correct ratings as given in the component list. Power ratings of D1 and P1 must be properly confirmed, as well as the voltage ratings for the capacitors. If a 16V zener is not available, select another standard value which is the nearest. This will affect the output voltage range.

Calibration

If you decide to use a voltmeter and an ammeter with your power supply, calibration of the potentiometer dial is not necessary. However, if you construct the low cost version without the voltmeter and ammeter, you will have to calibrate the potentiometer dial using a good multimeter connected across the output.

The potentiometer dial can be calibrated in 1V or 15V steps as desired.

9

Table 1
Checklist of test voltages

Figure 9
Construction of the power supply

Figure 10
Mains socket with built-in fuse holder

Figure 11
Voltmeter, ammeter connections detail

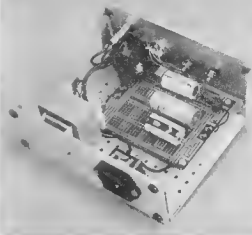
Components

- R1 - 220 Ω 1/2W
- P1 - 1K Linear Pot. 1/2W
- C1 - 2200 μ F / 40V [Electrolytic]
- C2 - 1 μ F / 25V [Tantalum]
- C3, C4 - 470 μ F / 25V [Electrolytic]

B1 - Rectifier bridge (500 mA or 1A)

D1 - 16V 1W Zener diode

T1 - BD 241 [with suitable heat sink]

T1 - 18V / 500 mA Transformer

La - Indicator lamp [230V]

S1 - Double pole mains switch

Si - 200 mA Slow Blow Fuse

Other parts:

- 1 Suitable casing
 - 2 Mains Cord
 - 1 Mains Cord
 - 1 Mains socket with fuse holder
 - 1 Suitable PCB
 - 1 Knob for potentiometer (preferably with dial)
 - 2 Banana sockets [Red & Black]
 - 6 Soldering lugs
 - 1 Voltmeter [0 to 20V] - Optional
 - 1 Ammeter [0 to 500 mA] - Optional
- [See figure 11 for connections of Voltmeter and ammeter]

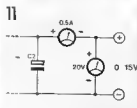

Attachment for Multimeters.

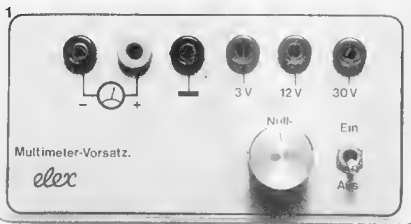

Figure 1
Suggested panel layout for the multimeter attachment. The three banana sockets for 100 voltages should be red and the earthing socket should be black. The connecting sockets for the multimeter must be correctly marked with + and -.

Figure 2
Example of voltage measurement with a multimeter connected across one resistance of a voltage divider. The input resistance of the multimeter appears in parallel with the resistance R2 and draws a load current, effectively changing the ratio of the voltage divider. This results in a misleading voltage reading.

Figure 3
Circuit of the high resistance Multimeter Attachment. The field effect transistor T1 effectively presents a very high input resistance to the voltage being measured. The actual points of measurement are isolated from the multimeter by the attachment and loading of the test-voltage by the multimeter is avoided.

Multimeters are widely used as general purpose measuring instruments. When a multimeter is used for measuring voltages, the reading shown by the meter may not always be very accurate and reliable if the input resistance of the multimeter is not very high. The higher the input resistance of a multimeter, the more accurate is the voltage reading. Unfortunately, for multimeters with very high input resistance, the cost is also very high.

The multimeter attachment described here partially solves this problem. This attachment provides a very high input resistance for DC voltage measurements on a multimeter, and its cost is not very high. Your DC voltage measurements will be much more accurate by using this attachment with the multimeter.

The multimeter attachment has an input resistance above 1M Ω in the 3V range, above 4M Ω in the 12V range and

above 10M Ω in the 30V range. It uses a supply voltage of 9V and the current consumption is below 1mA. The only disadvantage of this attachment is that it is not suitable for AC voltage measurements. However this does not reduce the utility of the attachment considerably because most of the times we are concerned with DC voltage measurements.

Input Resistance

Input resistance of a multimeter is specified as

K Ω /V. Generally this value varies from 1K Ω /V to 100 K Ω /V, depending on the type, quality and price of the multimeter. The commonly encountered value is 20K Ω /V. The actual input resistance depends on the selected range. For example, in the 2V range the input resistance will be 20K Ω /V x 2V = 40K Ω , whereas the input resistance in the 10V range will be 20K Ω /V x 10V = 200K Ω .

Now, let us see how the input resistance affects the voltage measurement. We shall again restrict this discussion only to DC voltages, as the attachment described here is meant for DC voltage measurements.

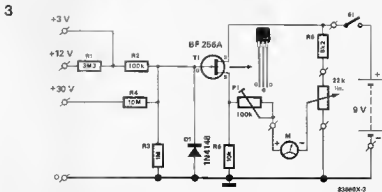
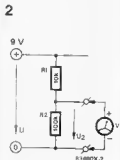

Figure 2 shows a typical situation where the DC Voltage is being measured across one resistance of a potential divider. As the total voltage across (R1 + R2) is 9V, we can accurately calculate the voltage available across R2 as

$$U_2 = U \cdot \frac{R_2}{R_1 + R_2}$$

$$= 9 \text{ V} \cdot \frac{100 \text{ k}}{100 \text{ k} + 10 \text{ k}}$$

$$= 8,18 \text{ V}$$

If we measure this voltage using a multimeter on its 10V range, with an input resistance of 1K Ω /V, the reading given by the multimeter will be 4,29 V, instead of 8 18V Surprising!

Not so surprising, if we see what effect the input resistance is having on the voltage measurement. The input resistance c. 1K Ω /V on the 10V range means that we have effectively a 10K Ω (R_i) resistance in parallel with the 100K Ω resistance R2 in figure 2. Thus a total resistance R_g given by

$$R_g = \frac{R_2 \cdot R_i}{R_2 + R_i}$$

$$= \frac{100 \text{ k}\Omega \cdot 10 \text{ k}\Omega}{100 \text{ k}\Omega + 10 \text{ k}\Omega}$$

$$= 9,09 \text{ k}\Omega$$

is introduced in the potential divider circuit. The voltage U₂ will now change to

$$U_2 = U \cdot \frac{R_g}{R_1 + R_g}$$

$$= 9 \text{ V} \cdot \frac{9,09 \text{ k}\Omega}{10 \text{ k}\Omega + 9,09 \text{ k}\Omega}$$

$$= 4,29 \text{ V}$$

This is what the multimeter reads as U₂. The measurement is totally misleading as the actual value of U₂ should

have been 8 18V. From the above calculations it becomes quite clear that the input resistance of the multimeter plays a very important role in deciding the accuracy of reading. Once again referring to the circuit of figure 2, we can observe that if the input resistance of the multimeter was considerably high compared to R₂, it would have given a more accurate reading.

The Circuit

Now that we have seen the effect of input resistance of a multimeter on the voltage measurement, let us find out how we can increase the effective input resistance of the multimeter.

One such circuit which effectively increases the input resistance of a multimeter is given in figure 3. The field effect transistor T1 is the most important component in this circuit. The FET (Field Effect Transistor) used here is N-Channel barrier type. Going into the theory of operation of the FET is beyond the scope of this article. The only important fact to be noted here is that an FET has three terminals called Gate (G), Drain (D) and Source (S).

The internal resistance between the Gate and the Source is very high, and its normal value is few Giga ohms (1 Giga ohm = 10⁹ Ω). Thus the circuits using FETs have a very high input resistance. The part of the circuit which decides the effective input resistance of the multimeter attachment is shown separately in figure 4. The resistance shown as r_{GS} corresponds to the Internal Gate to Source resistance of the FET. This resistance appears in series with the externally connected resistance R5 and this series combination of R5 and r_{GS} appears in parallel with resistance R3. As r_{GS} is very high compared to R5 and R3, the effective

4

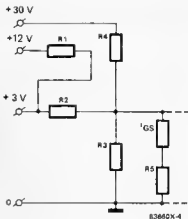

Figure 4

The effective input resistance of the attachment depends entirely on values of R1, R2, R3 and R4

Figure 5

The SELEX PC6, has enough space to hold the entire circuit of the attachment including the 9V battery pack.

Component List

R1 - 3 3M Ω
 R2 - 100K Ω
 R3 - 1M Ω
 R4 - 10M Ω
 R5 - 10K Ω
 R6 - 8 2K Ω
 P1 - 100K Ω (Preset Potentiometer)

P2 - 22K Ω (Linear Potentiometer)
 D1 - 1N4146
 T1 - BF 256 A (FET)

Other Parts

S1 - ON/OFF Switch
 1 9V battery pack (Miniature)
 1 9V battery pack connector clip
 1 SELEX PC6 (40 x 100 mm)
 1 Potentiometer Knob
 6 Banana Sockets (3 Red, 1 Black 2 Blue)
 1 Suitable casing

Soldering pins, Flexible hook-up wires, Rubber band for battery (or any other suitable battery holder if available)

5

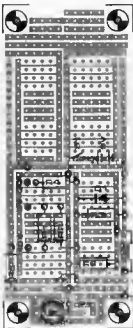

resistance to the combination of R3 in parallel with (R4 + rGS) is almost equal to R3.

The input resistance of the attachment thus becomes very high and can be calculated as follows

$R2 + R3 \approx 1.1 \text{ M}\Omega$ in the 3V range

$R1 + R2 + R3 = 4.4 \text{ M}\Omega$ in the 12 V range

$R3 + R4 \approx 11 \text{ M}\Omega$ in the 30V range

The FET T1 functions as a Source Follower. The voltage on the source terminal follows the voltage available on the Gate terminal. The amplification factor in this configuration is almost equal to 1. However, as we are not interested in any signal amplification from this circuit, it is of little importance. The FET here has the function of increasing the effective input resistance. It effectively passes on the voltage at the input of the circuit to the output without drawing a high load current from the voltage under measurement.

The multimeter is connected between the preset P1 and potentiometer P2 as shown in figure 3. The components T1, R5, R6, and P2 form a bridge circuit. (Refer to page 165 of our January 1986 issue). Preset pot P1 and the multimeter form the middle branch. By adjusting the setting of potentiometer P2, the multimeter reading can be set to zero volts, when no input is present. The function of P1 is described later.

The diode D1 protects the FET against negative voltages on its Gate. This prevents any damage to the FET in case the voltage under measurement is connected to the input with a reverse polarity. The diode never allows the Gate voltage to fall below 0 V.

Construction Details

A SELEX PCB will have enough space to mount all components of the attachment, including a 9V battery pack.

The component layout is shown in figure 5. All the usual precautions and rules of construction should be properly followed. Special attention must be given to the terminals of FET and the polarity of the diode. The battery pack can be placed on the free area of the PCB. A rubber band can be used as the battery clamp as shown in figure 6. This is possible by using two bent soldering pins on each side of the battery pack and then attaching the rubber band through them. This will securely hold the battery pack in its place.

Compensation

Once the circuit construction is complete, it can be tested for proper operation. The voltage on the Source terminal of the FET should be approximately 2V with no input voltage connected at the input terminals of the attachment. If this voltage is correct, a multimeter with an input

resistance preferably around $20\text{K}\Omega/\text{V}$ can be connected in its place with correct polarity. With no input voltage present at the test terminals of the attachment, the multimeter reading can be set exactly to zero volts by adjusting the potentiometer P2. It is not enough just to set the zero reading. The full scale reading also must be correctly compensated.

For adjusting the full scale deflection, we need accurate voltage reference of 3V, 12V or 30V. The reference voltage can either be obtained from a good variable voltage supply, or 3V can be obtained using 1.5V battery cells (These cells should be brand new, so that they really give 1.5V each.)

If a good variable voltage supply is not available for the compensation adjustment, one has to accept the slight inaccuracy that may result from using battery cells as reference voltage.

The reference voltage available is connected to the corresponding input socket. The multimeter is set on the 1V or 2V range and the preset pot P1 is now so adjusted as to get

the needle of the multimeter on the full scale deflection mark, of that range. Once this compensation is done, it also holds good for the other two ranges. When using the multimeter with the attachment in future, it must be set to the range (1V or 2V) on which it was compensated.

Comparison

The attachment circuit described here was actually tested and the reading accuracy was compared using a highly accurate Digital Voltmeter (DVM).

the deviation in readings were observed to be as follows

0.19% deviation on 3V range

0.26% deviation on 12V range

1.11% deviation on 30V range.

The average deviation thus lies at about 0.52%. Quite an acceptable tolerance, considering the low cost of the attachment circuit.

Figure 6
Installing the PCB in the case is easy. An inexpensive way of holding the 9V battery pack in place is four bent soldering pins and one rubber band.

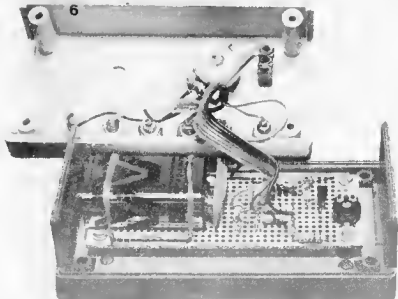

DATA ACQUISITION SYSTEM

Solartron announces the launch of their new Micro DELEGATE distributed Data Acquisition System. Micro DELEGATE has a capacity to handle 8 ORION data loggers - a total of 3600 data input channels and with any ORION located up to 1200m from the computer. The system is able to measure voltages, current resistance, status, events, period and frequency. Furthermore, specific transducers for example PRT's, strain gauges, thermocouples, pressure, flow and speed can all be measured and directly processed into effective information by the ORION.

Micro DELEGATE can incorporate both Solartron's ORION alpha and delta range of data loggers. By using the ORION delta with its built in BASIC programming language, the Micro DELEGATE system is further enhanced by providing even greater flexibility in the reduction of data.

Using the microprocessing power of ORION much of the house keeping and data reduction can be DELEGATED releasing the central computer for other tasks such as processing data, generating displays and compiling special reports.



For further details, please contact

HINDUSTAN INSTRUMENTS LIMITED
603 Vastal Bhawan
95 Nehru Place
New Delhi - 110 019

PROXIMITY SWITCHES

IEC offers a new line of inductive Proximity switches which are basically contactless limit switches. In addition, they feature applications like high speed counting. These sensors

feature solid state circuitry with no moving parts, and their encapsulated construction makes them resistant to oils, acids, coolants, vibrations, etc.



Sensors are available in both AC and DC versions with sensing ranges from 5 to 20 mm. The AC version can be used to count up to 5 parts/sec while, the DC version can be used for up to 200 parts/sec.

For further information
INDIAN ENGINEERING COMPANY

Kalra Menson,
P.B. NO 16551, Worli Naka,
Bombay 400 018

POWER PUSH BUTTON SWITCH

Rejumar engineers offer a new power push button switch incorporating the latest advances in switching technology.

The switch is rated at 5 amperes continuous load and has double pole single throw switching configuration.

The switch incorporates bimetal sandwiched contacts & for fail safe operations it has built in barriers for preventing electrical cross over.

NEW PRODUCTS



For further information
Rejumar Engineers
106, Bajsons Ind Estate
Chakala Road,
Andheri (East)
Bombay 400 099 India

PLASTIC MOULDED DOUBLE DIN STD INSTRUMENT CASE "COMTECH" — T-192 is a double DIN standard Instrument Case having over all dimensions of 192 mm x 96 mm x 155 mm. The case is offered in three different styles.

PANEL FLUSH MOUNTING

When used as panel mounting it offers a Metal chassis mount various components like Transformers, coils etc. The front & back of which can be easily detached to perform various drilling, punching operations to suit individual needs.

The front is covered with a white plastic Bezel & black plastic frame with matt finish & give a professional look to the instrument.

Two instrument clamps at top & bottom help the case to be fixed on the panel.

The Case is most suitable for panel Mounting instruments, like edgewise meters, temperature indicators & controllers etc. as also various table-top test instruments, clocks, hobby instruments etc.

For further details please contact
COMPONENT TECHNIQUE 8, Orion Apartment
29 A Lallubhai Park Road,
Andheri (West)
Bombay 400 058

DIGITAL WATTMETER

Economy's Digital Wattmeter represents versatility and ruggedness. Uses of latest LSI Chips makes it accurate and versatile. It out classes dynamometer type wattmeters. It is also well protected to ignore load transients. It is used in many industries where measurement and control of power plays important role like heaters, furnaces and appliances manufacturing units. This instrument has various features such as Direct Digital Display of values, sunlight visible LED display, High sensitivity by use of high precision components. Selection of 2000 W or 4000 W ranges, Glass epoxy PCB for trouble free operation etc.

For further details, please contact —

ECONOMY ELECTRONICS
15, Sweet Home,
Plot No 442, 2nd floor
Pamber Lane,
Off Tulsī Pipe Road Mahim,
Bombay - 400 016

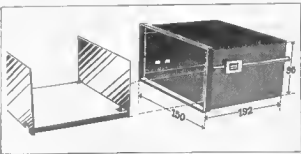

NEW PRODUCTS

DIGITAL DC MICRO-VOLT METER VMV15

A clever indirect measurement with VMV15 eliminates costly & complicated ELECTROMETER for conductivity measurement upto few thousand Meg Ohms. In addition VMV15 possesses all advantages of digital meter over analog.

VMV15 has a resolution of 1 micro-volt. With optional H V probe the range covered is upto 2000 Volts. Provision of optional adaptor converts the meter to DC PICO-AMMETER with 1 pA resolution. Battery operation makes it more versatile for floating measurements, like that of measuring MICRO-OHMS, with constant current source.



For further information
ELCOM
103, Jaygopal Industrial
Estate 8, Perulekar Marg
Dadar, Bombay 400 028

AUTO SCANNER

ARUN has introduced a Digital Auto Temperature Scanner. The Channel switching is based on CMOS technology instead of conventional Reed switched. The scanning rate can be selected from 1 second to 15 seconds per channel. The Hold mode facility helps to freeze any particular channel reading. The Auto Temperature Scanner is available for all standard industrial thermocouples.

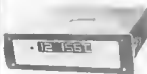

For further details
M/s ARUN ELECTRONICS
PRIVATE LIMITED
8-125/126 Ansa Industrial
Estate, Saki Naka,
Saki Vihar Road,
Bombay 400 072
Phones: 583354/581524

MOTOR TEMP MONITOR

The 'Ador 85' is used for monitoring the temperature of windings and bearings of rotary machines which use RTDs as sensors. This unit continuously monitors the temperatures and prevents motors from burning due to excessive heat.



The instrument can accept eight inputs six from windings and two from bearings. The unit is compact and suitable for panel mounting. It can be supplied with special enclosures for use in dusty and corrosive environments.

For further details, quote ref
No P5/2/84

Advan-Oerlikon Limited
Post Box No 1546,
Bombay 400 001

DIGITAL MULTIMETER

MECO has just introduced the model MIC-6E Digital Multimeter which features a single knob operation for all functions.

It measures AC & DC currents from 200 μ A to 10 A with a min resolution of 0.1 mA, AC voltage upto 750 V and DC voltage upto 1000V, Resistance from 200 ohms to 20 megohms, diode checks and continuity tests.

It has an accuracy of 0.5% + 1 dgt for DC Amps/Volt & Resistance measurements and 1% + 3 dgt for AC Volt/Amp measurements. It can also measure temperature.



It is overvoltage protected on all the ranges except the 10A range. It has facilities for low battery indication and overload indications. It operates on a 9V cell with battery life in excess of 800 hours.

For further information,
MECO INSTRUMENTS
PVT LTD
Bharat Industrial Estate,
T J Road, Sewree
Bombay 400 015
Phones: 413-7423,
413 2435, 413-0747.

MICROPROCESSOR TRAINER

Professional Electronic Products offers a Low Cost Microprocessor Trainer UP 85 has been designed for students of engineering colleges who wish to gain an understanding of microprocessor, their architecture, operation and programming.



UP-85 is based on the single power supply 8-bit Microprocessor Intel 8085A.

Four digit hexadecimal display for address and two-digit hexadecimal display for data help the user to look in to the system at any time. A 28-Key keyboard and a AK byte monitor helps the user to control the operation.

Contact
PROFESSIONAL ELECTRONIC
PRODUCTS
POST BOX NO 316
DELHI ROAD
MEERUT 250 002

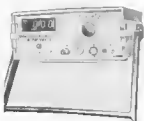

For details contact .

VASAVI ELECTRONICS
(Marketing Division)
630 Alkarun Trade Centre
Raniganj
SECUNDERABAD 500 003
PHONE 70995

KEY LOCK SWITCH

ELCOM has recently introduced a Key Lock Switch Type KLS-5. This reliable Key Lock Switch provides added safety to electrical and electronic equipments and prevents unauthorised use.

Panel Projection 6 mm
Body Bright Chrome Plated
Action 3 Pos. SPDT
Contacts Resistance 20 Milliohm
Rating 125 VAC/5A, 250 VAC/3A

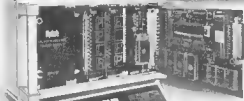

Aplab is the source

Aplab is the largest private manufacturer and exporter of professional electronics equipment in India. Aplab specializes in small quantity non-consumer products and a wide variety of custom made equipment. Aplab's wide range of standard products include μ P based instrumentation systems, GPIB based instruments, Oscilloscopes, Signal Generators, DC Power Supplies, Inverters. Aplab is serving the nation by

catering the vital needs of Defence, P & T, Railways, Research Centers and all the major, public and private sectors

Aplab has a strong R & D base with more than 200 qualified Engineers and Managers and welcomes R & D projects.

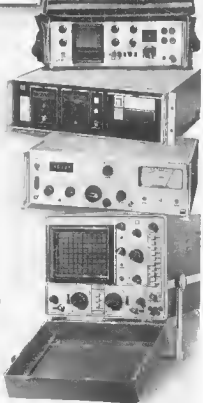

Aplab

Applied Electronics Ltd.

Aplab House, A 5/6, Waqle Industrial Estate, Thane 400 604, Bombay, India
Tel 59 18 61/62/63 Tlx. 011 719799 APEL IN. Cable: APLABTHANA

IC SOCKETS

HIGHLY RELIABLE

CONSISTENT SUPPLY

AT AFFORDABLE PRICES!

Socket all your IC's with
CHAMPION IC Sockets and MULTIPLY* your PROFITS!!

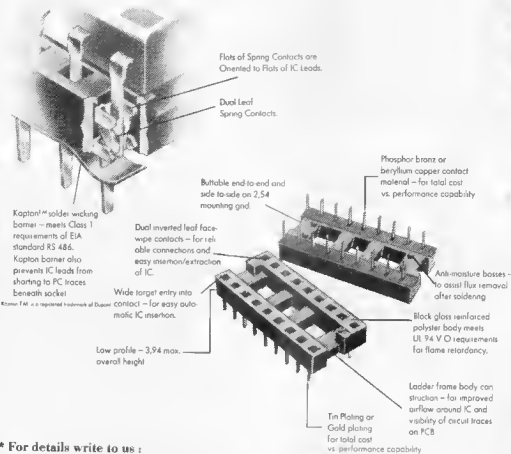

* For details write to us :

Champion Electronics Pvt Ltd.

In Joint Venture with
CAMBION
 MILLAND ROSS CORP. U.S.A.

Champion Electronics Pvt. Ltd.
 S-17, MIDC, Shreeji, Pune 411 028, INDIA
 Phone : (0212) 83781, Cable : CHAMPION
 Telex : 0145-333 MCCI IN, 0145-505 MCCI IN

ORIENT/ICE 3/86

classified ads

Available rechargeable torch using maintenance free battery Powerful beam upto 200 feet. Operates two hours, when fully charged Send Rs 225/- by M O /D.D Postage Free SUN ENTERPRISES, 56/1, Industrial Estate, Vitthalwad, Bhavnagar 364 001

Walkie talkie transmitter circuits available Simple circuits Rs 15/- Write to RND Electronics 12-11-1313, Raghavendranagar, Sacundatnbad - 500361

8085 Microprocessor (trainee in brief case Rs 2970/- Built in EPROM PROGRAMMER power supply 2K CMOS RAM with diy-cell back up expandable to BK 12K, user EPROM New Age Electronics third floor Laxmi Mahal, Near Vandana Cinema, Agra Road, Thane 400 602

READ all ELECTRONICS BOOKS at 1/3 rd of original price For details contact SRI KRISHNA ASSOCIATES, B/25, Mahesh Co-operative Housing Society Dattapada Road Bombay - 400 066

PCB track patterns for Battery operated NiCd charger and universal RF board.

86002 Battery-operated NiCd charger

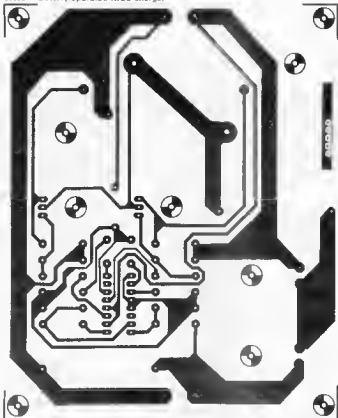

86000 Universal RF board

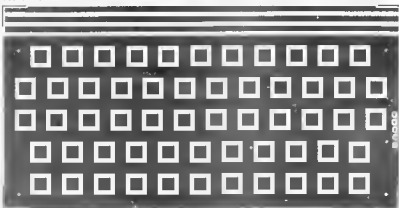

Advertisers Index

ADVANI-OERLIKON	3-11
ACE COMPONENTS	3-10
APEX	3-71
APLAB	3-63
ATRON ELECTRONIC	3-68
BAKUBHAI AMBALAL	3-14
CHAMPION ELECTRONICS	3 69
COMPONENT TECHNIQUE	3-12
DEVICE ELECTRONICS	3-13
DYNALOG MICRO SYSTEM	3-76
ECONOMY ENGINEERING	3-12
ELCOT	3-07
GALAXY ENTERPRISES	3-08
IEAP	3-06
INDIAN ENGINEERING	3-10
KLAS ENGINEERING	3-08
KOENIG ELECTRONICS	3-10
LEADER ELECTRONICS	3-08
LEONICS	3-70
MOTWANE	3-67
OSWAL ELECTRONIC CO.	3-02
PADMA	3-66
PIONEER	3-06
PRECIOUS KITS	3-62
RAJASTHAN ELECTRONICS CO.	3-02
ROCHER ELECTRONICS	3-06
SAINI ELECTRONICS	3-70
SIEMENS	3-61
SUCHA ASSOCIATES	3-68
TESTICA	3-71
TEXONIC	3-70
UNLIMITED ELECTRONICS	3-68
VASAVI	3-12
VISHA	3-75
YABASU	3-04
ZODIAC	3-72

PACKAGE DEAL

FOR ENGINEERING COLLEGES AND TECHNICAL INSTITUTIONS

Dynalog Micro-Systems

14, Hanuman Terrace, Tara Temple Lane,
Lamington Road, Bombay 400 007.

DMS

To
The Principal

Dear Sir,

You already know us as a leading manufacturer of Microprocessor Trainer Kits and development systems.

Today, we are pleased to introduce our new offer - 'A Package Deal' for Engineering Colleges and Technical Institutions. Under this scheme we shall provide a complete package of Microprocessor and Computer education products to match the syllabus being covered by you.

For the **Microprocessor Interfacing and Peripherals Laboratory** - we have various Trainer Kits based on 8085, 8086, 280, 6802 and 68000, supported by a wide range of interfacing and peripheral controller cards. You just have to send us a copy of the syllabus prescribed by your University and we will select the best package to meet your need.

For the **Microprocessor Applications Laboratory**, we have many optional attachment cards which allow you to perform application oriented experiments using the basic trainer kits.

For the **Computer Organisation Laboratory** - we offer two full fledged systems, one based on Z80 called 'Super 80' with CP/M operating system and the other system is compatible with IBM PC/XT. Using these systems you can successfully conduct the **Computer Organisation Laboratory**. The peripherals provided with these systems can also be used for experiments in the other two laboratories.

For detailed information on the 'Package Deal', please get in touch with us soon. Don't forget to send a copy of the prescribed syllabus.

Thanking you and looking forward to your reply.

Yours faithfully,
For Dynalog Micro-Systems

Shivaji Adhalrao
(Shivaji Adhalrao)



14, Hanuman Terrace, Tara Temple Lane, Lamington Road, Bombay 400 007.
Tel: 362421, 353029 Telex: 011-75614 SEVK IN Gram: ELMADVICE