

22
February
1985

elektor INDIA

Rs. 7.50

electronics

BASIC (PART 3)

μ P-controlled frequency meter
fourth in our series of measuring instruments

Portable guitar amplifier
two articles for guitar lovers

Cassette interface for VIC 20/64
overcomes one of Commodore's shortcomings

• CMOS function generator • Simple transistor tester • Crystal time-base

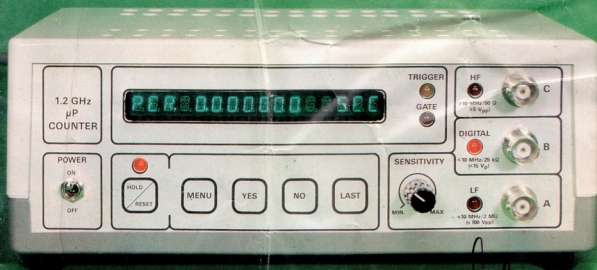

Swish Singh

elektor contents

Volume 3-Number 2

EDITOR: SURENDRA IYER

PUBLISHER: C. R. CHANDARANA

PRODUCTION: C. N. MITHAGARI

ADVERTISING & SUBSCRIPTIONS

elektor ELECTRONICS PVT Ltd.

Chotani Building
52 C, Proctor Road Grant Road (E)
Bombay-400 007.

DISTRIBUTORS: INDIA BOOK HOUSE

PRINTED AT:

TRUPTI OFFSET

103, Vasan Udyog Bhavan,
Off Tulsi Pipe Road,
Lower Parel, BOMBAY-400 013.

Elektor India is published monthly under agreement with Elektor B.V. Holland, August/September is a double issue.

SUBSCRIPTION

INLAND

1 Yr Rs. 75/- 2 Yrs Rs. 140/- 3 Yrs Rs. 200/-

FOREIGN

One year Only

Surface mail Rs. 125/- Air mail Rs. 210/-

The Circuits are for domestic use only. The submission of designs, of articles to Elektor India implies permission to the publishers to alter and translate the text and design, and to use the contents in other Elektor publications and activities. The publishers cannot guarantee to return any material submitted to them. All drawings, photographs, printed circuit boards and articles published in Elektor India are copyright and may not be reproduced or imitated in whole or part without prior written permission of the publishers.

Patent protection may exist in respect of circuits, devices, components etc. described in this magazine.

The publishers do not accept responsibility for failing to identify such patent or other protection.

INTERNATIONAL EDITIONS EDITOR: P. HOLMES

Dutch edition: Elektor b.v.
6190 AB Beek (L),
the Netherlands

German edition: Elektor Verlag GmbH,
5133 Gangelst, W. Germany

English edition: Elektor Publishers Ltd.
Elektor House, 10 Longport,
Canterbury CT1 1PE, Kent, U.K.

French edition: Elektor Sari, Le Sésau,
59270 Bailletul, France

Italian edition: Elektor, 20092 Cinisello B., Italy

Spanish edition: Elektor, Av. Alfonso XIII,
141, Madrid 16.

Greek edition: Elektor, Karaiskaki 14, Voula,
Athens

Turkish edition: Elektor Yayıncılık ve Ticaret A.Ş.,
Karakoy Istanbul

COPYRIGHT © ELEKTUR B.V. —
THE NETHERLANDS 1984

| | |
|--|------|
| news, views, people | 2-18 |
| tea leaves | 2-20 |
| A light-hearted look at the coming decade. | |
| selektor | 2-21 |
| Computers of the future. | |
| Commodore cassette interface | 2-23 |
| This circuit enables Commodore's VIC20 and C64 PCs to be interfaced with virtually any cassette recorder. | |
| VHF/UHF modulator | 2-26 |
| Improves the images obtained with PCs, video cameras, VCRs, and similar equipment. | |
| portable guitar amplifier | 2-28 |
| A project that gives colour to the basic guitar sounds for only a modest outlay. | |
| 30 watt a.f. output stage | 2-34 |
| A good-quality power output stage suitable for use in the guitar amplifier. | |
| JSR swap | 2-38 |
| Makes 6502-based computer systems more versatile by duplicating pages zero and one in RAM. | |
| rumble detector | 2-39 |
| Detects ultra-low frequency noise that could spoil the pleasure you get from your hi-fi system. | |
| µP-controlled frequency meter | 2-42 |
| A highly-sophisticated do-it-yourself frequency counter that compares with professional instruments in almost everything except price. | |
| CMOS function generator | 2-56 |
| Generates three waveforms | |
| simple transistor tester | 2-58 |
| economical crystal time-base | 2-59 |
| A 50 Hz 'bench mark' | |
| low voltage stabiliser | 2-59 |
| Battery powered voltage regulator | |
| electrolytics run dry | 2-60 |
| The article describes and discusses the merits of the different kinds of electrolytics, arriving at a surprising conclusion. | |
| applicator | 2-62 |
| 20 W output amplifier based on LM1875 | |
| CMOS ICs | 2-64 |
| market | 2-67 |
| switchboard | 2-69 |
| appointments | 2-70 |
| missing link | 2-72 |
| index of advertisers | 2-74 |

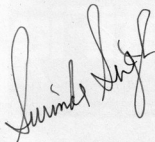

HM
307

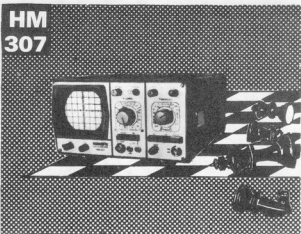

307 KNOCKS OFF ALL COMPETITION

scientific HM 307 winner of WISITEX '81 **First Prize** and **still** the only portable scope with a **single touch** component tester.

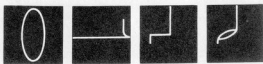

Capacitor 33 uF Transistor E-C Transistor B-E BE 1 uF + 68 ohms

Specifications :

- Bandwidth (-3 db) : 10 MHz (-6 db) : 15 MHz
- Fast 35nS risetime
- Sensitivity : 5mV—20V/cm
- Auto or variable trigger upto 30 MHz
- Built-in component tester
- Excellent layout for quick troubleshooting
- Lightweight, only 4.5 kg

some products are so good that you don't have to boast about them

scientific

SCIENTIFIC SALES

A, Jati Colony, INDORE 452 004 Ph: 22498
Telex: 0735-267 Customer Services at: Bombay
Bangalore, Calcutta, Delhi, Hyderabad, Madras.

NOW THE LATEST BOOKS-KITS ARE AVAILABLE WITH US

DATA BOOKS :

synetics

TEXAS INSTRUMENTS
INCORPORATED

SEMICONDUCTORS



NATIONAL



MOTOROLA
— CMOS for contemporary use

RCA

INTERSIL

FAIRCHILD

ZILOG - 'GE' - ANALOG DEVICES SIEMENS - INTEL
SGS. ATES SILICONIX - TELEDYNE COOK BOOKS
OSADRNE BOOKS SYBEX BOOKS - TAB BOOKS
SAMS BOOKS - TOWERS BOOKS AND APPLE
COMPUTER BOOKS

PLEASE WRITE FOR DETAILS

ELTEK

BOOKS-N-KITS

6, RITCHIE STREET, 1ST FLOOR,
MOUNT ROAD, MADRAS-600 002

We also stock **ELEKTOR INDIA** kits & back issues.

How electronics can be childs play for your son!



Jetking®

Do-it-yourself kits

Jetking kits are designed to let your child pick up the basics of electronics while he builds a number of interesting and engrossing projects. And at Rs. 125/- it's the best way to introduce him to the electronics age:



Jetking: 350, Lomington Road, Bombay-400007.
Phone: 357101. **Jetking Electronics Pvt. Ltd.:** 3830
Parauddi House, Daryaganj, New Delhi - 110002. Phone:
260458. **Jetking Electronics:** Lomington Road, Bombay-
400007. Phone: 350041. **India's Hobby Centre:** Opp.
Plazo Cinema, Connaught Place, New Delhi 110001. Phone 352111

APPROVED IN ELECTRONIC CLASSES OF SECONDARY SCHOOLS.

El-Ci-Ar[®]

resistors

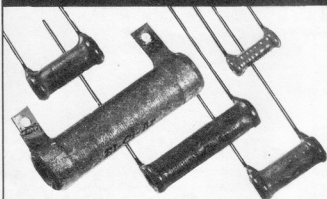

Manufactured by:

Neutroniks Pvt. Ltd.

68, Hadapsar Industrial Estate, Pune 411 013.
Phone: 70428, Gram: ELCIAR

Wire Wound Resistors— Varnish/Silicone Coated:

For Electronic instruments, Professional equipments, Power supplies, Audio amplifiers, Cassette decks, Radios, TVs and Fan regulators.

Non Inductive Power Resistors:

For Thyristor drives, Control panels, Induction heating furnaces and for test loading of Audio equipments.

Adjustable Resistors/Precision Wire Wound Resistors:

Available against specific requirement.

301 Rewa Chambers New Marine Lines
Bombay 400 020 Phone: 256076.

Sonika

INTIMATE FRIENDS OF AN ELECTRONIC ENGINEER

**Diamond
DESOLDERING
PUMP**

ADHESIVE
Thresal



ANTISTATIC
GUARANTEED
SWIFT SUCTION
ELEGANT FINISH
ATTRACTIVE PACKING
LARGEST SELLING
WIDELY ACCEPTED
NO COMPENSATOR
DESOLDERING PUMP

TRUSTED ADHESIVE
FOR COUNTLESS
APPLICATIONS IN
ELECTRONIC,
INSTRUMENTATION
INDUSTRIES,
REPAIRS SHOPS,
RESEARCH LABS AND
TECHNICAL INSTITUTES

RENDERS THE FIXTURES
VIBRATION PROOF
AVAILABLE IN
TUBES, TINS & DRUMS

DISTRIBUTORS

PRECIOUS ELECTRONICS CORPORATION
52 C, Proctor Road Grant Road (E) Bombay 400 007
Phone: 367456, 366476 GRAM DEEPTILAMP (GIRGAON BOMBAY)
8 ATHIPATTAN STREET, MOUNT ROAD, MADRAS 600 002
PHONE: 842718 GRAM DEEPTILAMP (MADRAS 600 002)

GRACE/877

LOW COST
HIGH QUALITY

Relays-a-Plenty

Series 112, 113, 117
25 Amps, 25 Amps,
15 Amps.

Series 106
10 Amps.

Series 108, 110
25 Amps &
30 Amps.

Series 134 to 136
15 Amps, 25 Amps,
& 30 Amps.

Series 103
8 Amps.

Open type
Series 118 to 124
0.5 Amps to 8 Amps.

Series 107
25 Amps.

Series 101
8 Amps.

Point of use
Series 102
8 Amps.

Point of use
Series 105
10 Amps & 28 Amps.

Series 125, 126
Flexi Relay

Series 127
25 Amps.

Series 118 to 123
0.5 Amps to 8 Amps.

Series 102
8 Amps.

Series 104
8 Amps.

Series 128
8 Amps.

Series 129 to 134
10 Amps & 20 Amps.

Eagleman
Relay Division

3/19-A, Kirti Nagar,
Industrial Area,
New Delhi-110015
Phone 535770
Grams EAGLETON

Engineers with its many years of
Engineering and Production
experience builds relays in all
quality levels. Relays from the
most exacting to the simplest in
operating specifications are
readily available at Eagleman.

Small or large quantity orders
receive the same careful attention
by the people that have the
"Eagle" Name.

Engineers become part
of your high gear in selecting the
correct type of relay to meet
your requirements.

APLAB becomes a cover story in Britain too!

A few months ago 'ELECTRONICS & COMPUTING', a leading UK monthly in electronics put APLAB'S 3337 Oscilloscope on its cover and made it a lead story.

Three page Technical Feature covering report on its performance by an independent agency was exactly as expected - very very complimentary*

Being on the forefront is not new for APLAB. Our esteemed customers here have always put us there. But to be on the cover in England is what would make all INDIANS proud. We thought we should tell you, specially since it is the very first Indian Electronic Product to become a cover story in U.K.

(*For getting a complimentary copy of the three page Review Article by Mr. David Green, just drop us a line).

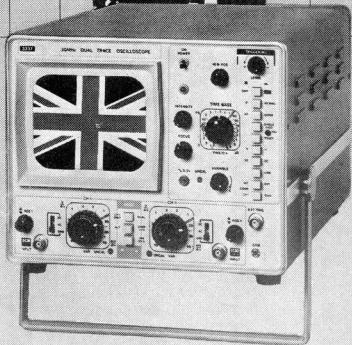

Aplab

Applied Electronics
Limited

Aplab House, A-5 Wagle Industrial Estate,
Thane 400 604 Phone : 591861 (3 lines)
Telex : 011 - 71979 APEL IN

LEADERSHIP THRU' TECHNOLOGY

APLAB 84



**A MADE IN U.S.A. label
is the only feature
we don't offer**

**"ALISDA
APPROVED"**

The Motwane 4½ Digit Multimeters DM-450 and 451 are as good as the best in the world. Developed in our inhouse R & D laboratory, these DMMs compare in terms of reliability, efficiency, performance, quality of design and manufacture; or simplicity in operation—with the Prime. The Motwane DM-450/451 offer a host of features, the most outstanding of which are:

- True R.M.S. volt and current measurements over a wide frequency range (Model DM-450).
- 10 microvolt resolution on AC and DC
- Imposing accuracy—Basic of 0.03% of reading + 1 digit and low Tempco.
- B.C.D. output for systems capability.
- Full protection against inadvertent overload.
- Sleek plastic casing for the most effective sealing, longer lasting good looks, making the instruments practically unbreakable.
- Quality that's exclusive, at a price that's not.

These 4½ digit, 5 function, 27 ranges DMMs measure upto 1000V on AC and DC, 2 Amps on AC and DC and 20 Megohm. With careful component selection, sophisticated L.S.I. technology and ultra precision resistors, they guarantee excellent long term stability, quick response time and greatest reliability.

Since instruments of this kind are most often used as a secondary standard, recalibration intervals are longer. These DMMs naturally include automatic polarity and zero, Hi Lo ohms, have only two terminals and are human engineered for the simplest, yet most efficient operation.

Anticipating your future need to build a system around these instruments, also available are the following optional accessories:

- Digital limit comparator for go-no-go checks.
- Digital printer for hard copy
- A simple quick mate jig for speedy G.C tests.

The DM-450 and 451 perform better because they are built better. We had you in mind when we designed them.



For further details write to:
THE MOTWANE MANUFACTURING
COMPANY PVT. LTD., at Gyan Baug,
Nasik Road 422 101 Tel.: 862977
86084 Telex: 752- 247 MMPL IN
Grams: MOTWANE or Gyan Ghar, Plot 434 A, 14th
Road, Khar, Bombay-400 052. Grams: MOTESTEM.

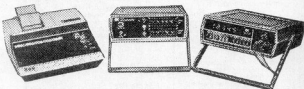

Cut here and mail

Please send literature and quotation

Name _____
Designation _____
Company _____
Address _____
Telephone _____ Telex _____

SELL ADS.MMC.12.84

O. K. INDUSTRIES., U.S.A.

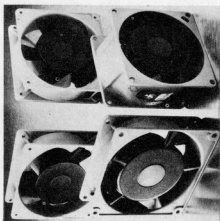

FANS

RF 3120-115/230

RF 4120-115/230

The RF 3120-115/230 and RF 4120-115/230 are both long-life high performance fans for any general cooling purpose.

Features:

- 80-105 CFM air movement.
- 4.70" (119.5mm) square x 1.51" (38.5mm) thickness.

Extra long life:

- Minimum service life 20,000 hours at 55°C (130°F)
- Minimum service life 10,000 hours at 70°C (158°F)

Wide Range of Operating Conditions.

- Highest quality insulating materials.
- Low winding temperature.
- High output torque.
- Highest grade sieve bearings.
- Wide temperature range -30°C to 70°C (-22°F to 158°F)

Outstanding Performance.

- Standard (high) speed fans have an extremely high airflow compared to other fans of identical dimensions.
- Low speed offers ultra low noise and low-leak flux type design.
- All aluminum die-cast.
- The fans can be mounted on either suction or discharge side.
- Impedance Protection.
- No damage will occur to the wiring even if the rotating parts are restricted.
- Extremely low noise level.

APPLICATION

- Computers (CPM, Peripheral & Terminal Equipment).
- ESS (Electronic Switch System).
- Data communications terminal equipment.
- Office Machinery, Appliances & Copying Machines.
- Measuring instruments.
- Numerical control (NC) units.
- Power Units.
- Acoustic equipment.
- Automatic vending machines.
- Air-conditioning & heating apparatus.

CONTACT

BALAJI ENGINEERING CO.

195, Brigade Road
Bangalore-560 001
Phone : 52411

BRANCH

BALAJI ENTERPRISES,

B-15, Prashanth Apartments,
Macintyre Road,
Secunderabad-500 003. Phone : 77490

SWITCHCRAFT

PROFESSIONAL GRADE SUBMINIATURE ROTARY SWITCHES

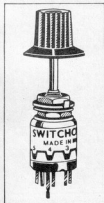

- Moulded In Terminals
 - Double Ball Detent Mechanism
 - Compact Size And Rugged Construction
 - Adjustable Stop
 - Silver Contacts
 - Totally Enclosed
 - Rated For 2A - 125 V AC
- Available In
- Single Pole - 8 Positions
 - Double Pole - 4 Positions
 - Four Pole - 2 Positions

For More Information, Contact:

SWITCHCRAFT
54/55, Crescent Mansion,
Gamdevi Road, Bombay-400 007
Phone: 357635

We Also Manufacture
Miniature
Toggle Switches

Dealers To Be Appointed

*GOOD NEWS FOR μ P ENTHUSIASTS

ASSEMBLE YOUR OWN 8085A BASED μ P KIT*

FEATURES:

- * Double side Glass Epoxy Board
- * All Components provided
- * Memory Available 1K RAM 4K ROM
- * Provision for Expansion RAM to 4K ROM to 16K
- * 28 + 4 User Defined keys
- * 8253 TIMER
- * TWO I/O Ports
- * ADDRESS & DATA BUS Available for Expansion
- * Complete Software & Users Manual Provided
- * Fully supported by Circuit Diagram Literature.
- * High Intensity 6 Digit LED Display
- * RS232C Serial Communication

RUSH YOUR ORDERS TO:

M/S. GEETA ELECTRONICS,

2nd Floor, Avenue Road,
BANGALORE-560 002.
Phone: 70503, 27855.

Two New Numbers
to Remember !

HM 203 HM 204

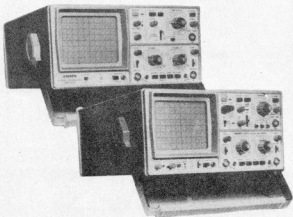

Scientific announces two new additions to its trusted and time-proven range of HM Series Oscilloscopes: HM 203 and HM 204 Dual Trace 20 MHz Oscilloscopes. These sleek new low-line portables incorporate the latest in international product design and features: a 140 mm rectangular flat-face CRT with illuminated internal graticule, 8 x 10 cm display, high 2 mV sensitivity and 20 MHz bandwidth, HF triggering up to 50 MHz, single touch component tester, sweep delay, and many more features never before available in this price range.

So remember HM 203 and HM 204, when you order an oscilloscope next. You will be glad you did.

scientific the affordable
portables !

Manufactured by:
SCIENTIFIC MES-TECHNIK PVT. LTD.
Formerly known as: SCIENTIFIC INSTRUMENTS (INDORE) PVT. LTD.
B-14, Pologround, Industrial Estate, Indore 452 003
Telephone: 31777, 31778; Cable: SCOPE, Telex: 0735-267

Customer Services at :
Bombay, Bangalore, Calcutta, Delhi, Hyderabad, Madras.

WE OFFER FROM STOCK

I.C.'s : TTL, CMOS, MOS, LSI,
Microprocessor, Micro computer etc.

Zener Diodes : 400 MW & 1 Watt

LED's : Red, Green, Yellow in
5mm and 3mm dia

IC Sockets : SMK & Memorex make

Trimpots :

Multiturn Bourn's, VRN & Beckman make

Single Turn cermets :

EC as well as imported

Floppy Discs :

8" as well as mini floppy of memorex,
& dyson make

Write to :



**ZODIAC
ELECTRONICS
CORPORATION**

Pushdarf Niwas 3rd Floor, 3, Chunam Lane, Dr. D. Bhadkamkar
Marg, Bombay-400 007, Phone : 5137225, 5135845

DESOL PUMPS



- Works effectively on single/double-sided PC Boards.
- Powerful vacuum suction.
- Low recoil action.
- Dependable performance.
- Assured results.
- Every stroke self cleaning.
- Replaceable tip.

**LARGEST
SELLING**

DESOLDERING PUMP

Internationally
Accepted

**With
Unmatched
Performance**

INDUSTRIAL RADIO HOUSE

12, Gandhi Bhavan, First Floor, Chunam Lane,
Off. Dr. Bhadkamkar Marg, Mumbai - 400 007

Phone : 38 21 04

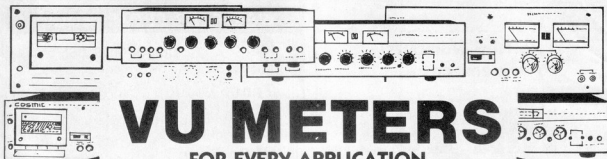

VU METERS

FOR EVERY APPLICATION

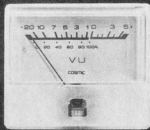
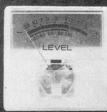
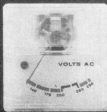
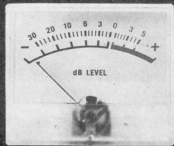

STOCKISTS

Western Region :
Precious Electronics Corporation.
 Chhotani Building, 52-C, Proctor Road,
 Grant Road (East), Bombay - 400 007
 Phones : 367459, 369478

Southern Region :
Precious Electronics Corporation.
 9, Athipattan Street, Mount Road,
 Madras - 600 002. Phone : 842718

Northern Region :
Tantia Electronics Co.
 422, Lajpat Rai Market,
 Chandani Chowk, Delhi - 110 006
 Phones : 238612, 233856

Manufactured by :

Padma Electronics Pvt. Ltd., Tamil Nadu

TOROIDAL

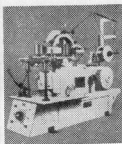

Coil
 Winding
 Machines

TIE

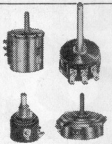

Precision
 Wire Wound
 Potentiometers

Contact Manufacturers

PATEL'S
ANALOG & DIGITAL MEASUREMENT CO. PVT. LTD.

A-6, Functional Electronic Estate,
 Bhosari Industrial Area,
 Poona 411 026 (INDIA) Phone : 83324



MEASUREMENTS
 MADE EASY



Measurement of INDUCTANCE, CAPACITANCE, RESISTANCE are greatly simplified by VLCR 7.

Connect the component to the terminals. VLCR 7 gives you directly the digital reading of value and its loss factor simultaneously.

FOUR TERMINAL measurement eliminates inherent errors due to lead resistance. GUARD TERMINAL provided eliminates errors due to lead capacitance.

VLCR 7 is the only instrument in India covering the widest ranges of 0.1 pF/uH/m ohm (ie. 0.0001 ohm) to 20.000uF/200H/20 M ohm.

Vasavi Electronics

(Marketing division)
 630, Alkarim Trade Centre, Ranigunj
 SECUNDERABAD-500 003.

ph: 70995
 gms: VELSCOPE



tea leaves . . .

Looking in our tea cups, we did not feel like starting the new year with reflections on super-chips or solid-state audio, but decided to wait and see how last year's tea-leaf patterns in this respect will fare. So, what would we like to muse over? Well, the first point is the state of technological development. This is still accelerating at an increasing rate: the super-chip of today is the standard chip of tomorrow. We regularly receive letters with cries for help like: "Help! I stopped my subscription two years ago, but because of withdrawal symptoms I have recently recommenced it. But I don't understand the circuits any more! . . ."

If we give free rein to our gaze into the future, we must assume that intelligent machines, far-reaching miniaturization, and affordable prices will become the norm. The second point is: where will we find ourselves in 1985? One thing is certain: new devices and equipment no longer amaze us. The

housewife will have a microprocessor-controlled microwave oven which automatically weighs the food and sets the appropriate temperature. All she has to do is to indicate that she is putting in a chicken and the oven does the rest. Or does it? The first time the oven is being used, you hear cries from the kitchen "Why is that stupid thing not working? It is program three . . . chicken . . . well then, why don't you start? Oh, the door was not closed properly. Sorry!" Click. So, we are no longer overwhelmed with wonder, but we do remain critical. If a 'stupid thing' does not do what we expect it to do, it's no fun any longer.

Utensils and crazes

When something is new and not too expensive, it sells. With some luck (and a lot of publicity) it may become a craze. Or a fashion. Or a normal utensil for everyday use.

What's the difference?

Why were Newton's marbles, the hula hoop, and the rubik cube crazes? Why were the Charleston, the mini skirt, and aluminium luggage racks in fashion? Why are telephones, automatic washing machines, and zips utensils? The difference appears to lie in the user-friendliness. Utensils are just, well, handy. They make it possible to do something you wanted to do in an easy manner. They have a purpose, they meet a need. Crazes and fashions are, initially, exciting, but after a while the novelty wears off — and all of a sudden they are no longer useful, or user-friendly; just plain dull.

Which brings us to the home computer. Craze or utensil? As they are now, we would say: craze. They are affordable, exciting — even addictive. If you manage to work with them you continue doing so. Sometimes until two or three in the morning. But why? And here's the crux of the matter. Because those

'stupid things' do not understand — and therefore don't do — what you want. They are not user-friendly. And that's why most computer owners get fed up with their machines. The standard games are boring and the 'family memory' was far more accessible when it was contained in the telephone book. Home programming is not so hot either. So?

In nine out of ten cases, the computer is put away in a cupboard. Nice when you have visitors, but for the rest... In the remaining one case, some interest remains. Elektor readers are prominent here. They want more. For them the computer is a hobby, not a utensil. For that, it is not yet sufficiently user-friendly.

The future

Back to the tea leaves. What can we expect? Which crazes will come and go? What utensils will come and become 'normal'? As we said, the cheap home computer appears to have all the hallmarks of a craze. The new MSX sets promise to become one hell of a craze: they are almost 'real', there are promises of much software, and they are not too expensive. But... user-friendly? No, not really. Do they meet a real need? No, not really.

What about that pocket-diary-in-a-wristwatch recently launched by Seiko? There is some doubt here. An 'old-fashioned' diary is cheap and convenient, and you can enter or alter information in it without first having to read the operating instructions. And yet, a watch is always with you, while a diary may accidentally be left at home. What are our real needs; in what

direction should we look for future utensils? Let's see:

■ **Peace and quiet.** A noise eradicator would be very desirable. Built into your easy chair, or at the head-end of your bed. Technically, it is quite feasible, but as yet very expensive.

■ **Communication,** but selective. This is a wide field, but to name one aspect that is definitely technically possible: a new British Telecom telephone service. John indicates on his phone that he would like to speak to his brother. All subscribers indicate when they don't want to be disturbed; for instance, by a switch on their phone. On the first occasion both John and his brother are free and available, the computer makes the connection.

■ **Information.** Assuming that you're interested in international news, chess, cartoons, and technical news, which paper do you read? Why, your own, personalized one, of course — ordered from a fully automated publishing company. Each morning your very own paper rolls from your own printer — no sports results, no stock exchange news, no gossip.

■ **Literature:** books and magazines, for relaxation or learning. Currently, these have many advantages: they are easy to use, legible, and relatively cheap. A computer screen is definitely not an improvement! And yet, the electronic system has its good points: the information is distributed easily and cheaply, and the 'covers' may be very compact — mini cassette or mini floppy. So, what do we need? A handy, not too expensive, battery-operated reading book with a clearly legible screen. Put in the cassette and on you go with your

novel. When you've finished it, you call for a new 'book' — by telephone, of course! Now, that will be user-friendly!

■ **Physical aids,** for healthy as well as for (lightly) handicapped people. Better hearing aids, for example, but also night glasses (with light amplifier), which are much more convenient and economical than torches. Or a muscle-energating massage belt to enable you to lose those pounds during breakfast — now, that could become a craze (and, like its current mechanical counterpart, it would be quite useless!).

■ **Elektor.** What sort of articles will we publish in *Elektor* in the 1990s? Using the same criteria as today — practice-oriented, using modern technology, broadly dealing with all aspects of electronics — the contents are bound to be quite different. Or are they?

We will publish audio preamplifiers, but with a 32-way input bus for those new audio ROMs.

And we will combine those new Mbyte memory ICs with those ridiculously cheap A/D and D/A converters to make a guaranteed-reproducible echo unit.

We will make a de luxe house telephone exchange for connection to the normal telephone network: this will be allowed by then.

We will make a 'music searcher' which tunes the radio (yes, that will still exist) to a transmitter that broadcasts the music of our liking and no advertising!

We will... well, we'll see... In any case, we'll make it interesting! ■

selektor

computers of the future

It is not all that long ago that computers worked only from a bunch of punched cards which could not be produced at home. Nowadays, computers are generally operated from a keyboard but this is still a long way from the desired goal of voice-actuated machines. Keyboards are highly restrictive because they mean that if a user wants to communicate with a computer he or she has to learn to write programs. As the main uses of computers will become cen-

tered more and more on office automation, data communications, and home work stations, it is extremely unlikely that more than a small proportion of users will be prepared to learn how to program — and why should they?

No, computers will have to come into much closer contact with the user to become a real tool of human thought. This means that computers have to become much cleverer than they are.

In essence, a computer is nothing

but an array of interfacing units: at the centre the microprocessor, swathed in software — machine code, compilers, assemblers, operating systems, languages, application programs, printers and/or screens. This is, of course, an unfortunate arrangement because any change at the user's end will normally affect all these peripherals, and therefore the very design of the computer.

Of course, even users of personal computers now have other devices at

their disposal for communicating with the computer. For example, the mouse is a small pointing device which when rolled along a desktop causes a pointer to move across the screen in a corresponding direction. Originally the mouse was operated through a pair of wires, but modern versions are cordless and communicate with the computer by infra-red signals. The mouse is also used to select icons, which are small graphic representations displayed on the screen to illustrate a computer function.

These are but first steps towards personalization of the computer, that is, giving the user facilities for moulding the operations more to his own requirements. The next steps will probably have to wait until the 32-bit microprocessors (such as Motorola's 68020S, Intel's 80386, Zilog's Z8000, or National Semiconductor's NS32032) and very large, inexpensive memories have become available in the course of the next few years. It is true, of course, that there are 32-bit computers on the market already, such as Apple's Lisa and Macintosh, both of which use Motorola's 68000 microprocessor. Unfortunately, the 68000 has only a 16-bit bus, so to the user these computers do not seem much faster than IBM's 16-bit PC. True 32-bit chips with a full-size bus will enable designers of PCs to give users much more flexibility: they can execute between two and three million instructions per second, that is as fast as many main-frame computers, and can process software programs more than three times as fast as the 68000.

Power requirements of these new chips are the same as that of the 68000 although they contain three times as many transistors. This low power consumption, which minimizes heat problems, and the high speed coupled with a large memory mean that very small but very powerful computers can be built. As a result, highly complex mathematical and engineering problems can be executed by a desktop computer and up to twenty people can work on the same computer file simultaneously.

Personalized computers have recently become available in the USA from Metaphor. These machines are customized for groups of users, such as accountants. Metaphor expects users, untrained in programming, to take it from there and write further applications for themselves. So, here is already an example of what can nowadays be done by the user

himself that had to be done by specialized programmers only a few years ago.

The two important developments are, however, the use of natural instead of man-made language (such as BASIC or FORTH) and graphics. The ability to speak into a computer instead of having to sit down at a keyboard will increase the uses of computers vastly. Basically, what is required for this is an interface between the user and the computer: a device such as a voice-actuated typewriter (vat) that can transcribe speech without having to understand it.

As the problems facing designers of automatic speech recognition (ASR) systems are enormous, large programmes, many government sponsored, have been initiated in Britain (the Alvey programme, named after John Alvey who chaired the committee that established the programme in 1982); in Europe (the European Strategic Programme on Research in Information Technology — ESPRIT); in the USA (Defence Advanced Research Projects Agency — DARPA; — Microelectronics and Computer Technology Corporation — MCC — the civilian counterpart of DARPA; and Semiconductor Research Cooperative — SRC); and in Japan (Institute for new-generation Computer Technology — ICOT — and the National Superspeed Computer Project). Several of the world's big computer companies have been working on automatic speech recognition (ASR) for some time. A few months ago, IBM announced that it had produced an experimental system with a ninety-five per cent recognition rate for a 5000-word business vocabulary. There are two approaches to ASR, of which one relies on a template recognition system. Templates are digital patterns used by a recognition algorithm to identify words. The other is based on pattern analysis of the forty phonemes that make up spoken English, and the 1600 transitions possible between each adjoining pair of them.

All the signs are that by the year 2001 we will be able to emulate HAL (but only as far as its positive aspects!) and command computers through natural language, because that is, and will remain, the most efficient and subtle, though complicated, instrument for human communication.

Visual representation is virtually useless to convey certain kinds of information. But when it comes to show the relation between, say,

forecast and actual sales, pictures come into their own.

Unfortunately, many companies have been frightened by the experience of Mindset. This Silicon Valley company makes an IBM compatible PC that produces high-quality graphics. After this set had been hailed by the press at its launch early last year, it flopped. Although there were market reasons for this, the main disappointment was that the idea that good graphics would create its own market among general business users was wrong. None the less, most consultants are forecasting that the computer graphics industry is heading for a huge boom, with a growth rate of more than forty per cent per year for the remainder of the 1980s.

Good graphics will be possible because PCs are becoming powerful enough to use bit mapping, a technique in which each pixel can be controlled individually. The most impressive PC with a bit-mapped high-resolution screen is Apple's Macintosh, while in the business market it is IBM's 3270PC/G (which, incidentally, also has a mouse).

Finally, two new printing technologies are becoming economically available. Up till now, there have been three basic types of printer: daisywheel, producing good quality print slowly and loudly; dot matrix, which uses a row of fine needles shot forward by electrical pulses to form the shape of letters and figures and is faster but less clear than the daisywheel; and heat transfer, which also uses needles but, instead of moving, these heat up momentarily.

But the future will almost certainly belong to laser and LCD (liquid crystal display) printers, both of which are fast (6...7 pages of A4 per minute), noiseless, and give a print quality where you do not notice any dots (pixels). Printers using these techniques are still very expensive, although market forecasts are that there will be a laser printer on the market for under £1000 in about a year's time. ■

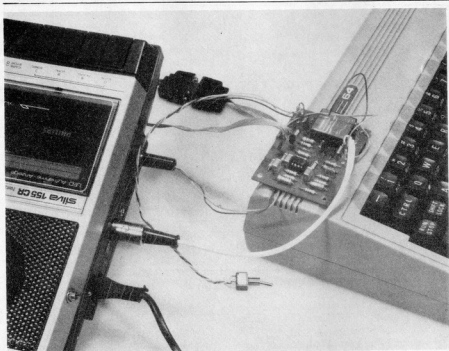

Commodore cassette interface

Necessity being the mother of invention this circuit was destined to be designed. The 'necessity' here is Commodore's insistence that the VIC 20 and C64 computers can only be used with a special cassette recorder supplied by . . . Commodore. One of our designers balked at the idea of buying a cassette recorder only for his computer when he already had a perfectly good audio recorder. Some kindly soul directed his outraged energy towards the nearest soldering iron and so was born THE Commodore cassette interface by Elektor.

As in many home computers, the data output by the VIC 20 and C64 via the cassette interface is in the form of a square wave signal with an amplitude of $5 V_{pp}$. The information input to the computer has the same form. The cassette connector also contains a so-called 'sense input' that enables the computer to check if the recorder's PLAY button is pressed. The Commodore will only activate its motor output if this is the case. The computer itself switches the recorder motor on and off and we will see later how this is actually done. First, however, we must see what happens if the computer wants to save a file on cassette.

THE interface in detail

The program to be saved appears in the form of pulses with an amplitude of $5 V_{pp}$ on the write output of the connector. This

amplitude is, of course, much too large to be saved directly on the tape so the signal is first reduced to about 200 mV by voltage divider R13/R14. This signal is then suitable for recording on the tape. The procedure for loading a program is somewhat more involved. The signal supplied by the recorder via a DIN or loudspeaker output socket is nowhere near square in shape and its amplitude is also much too small, at about 200 to 300 mV. The signal must therefore be amplified and its shape improved. A single op-amp (A1) increases the signal's amplitude by about six times. The offset of A1, and consequently of A2, is set to half the supply voltage by means of R3 and R4. The second op-amp is set up as a schmitt trigger which takes the signal from A1 and forms it into a clean square wave signal with an amplitude of $5 V_{pp}$. The computer can now load the program via the connec-

THE alternative

1

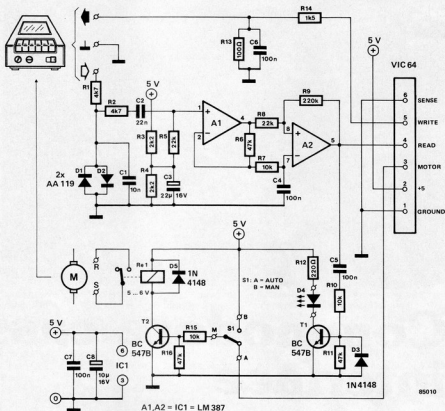

Figure 1. Looking at how simple this cassette interface is, you may wonder why Commodore found it necessary to insist on a special recorder. We did!

2

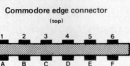

Figure 2. This is the layout used by the six-way edge connector on both C64 and VIC 20 computers.

tor's read input. A LED (D4) has been included in the circuit to show that this is actually happening. It will only light when transistor T1 is caused to conduct by a '1' appearing on its base but the logic levels switch far too fast to be seen with the naked eye. When data is being transferred the LED appears to be continually on. One obvious advantage of this LED is that it simplifies finding the start of a program. The motor in the cassette recorder must be switched on and off at the right times by the computer. Naturally enough this is done via a relay (Rel) instead of directly. When pin 3 of the connector goes high transistor T2 is switched on and causes

the relay to operate. First of all, however, the computer must be made to think that the PLAY button is pressed. This condition is simulated by connecting the sense input to ground, which is exactly what happens in the Commodore data recorder when this button is pressed. If the sense input is connected straight to ground, as we have done, we can then simply forget about it. The power supply for the interface is very kindly provided by the computer. As figures 1 and 2 show, pins 1 and 2 of the cassette connector are GND and +5V respectively. This makes a separate supply for the circuit unnecessary.

The interconnections

Before any data can be transferred all the electronics must be constructed and all interconnections must be made. A total of six links are needed at the computer side and the most important point here is to ensure that none of these are interchanged. The computer would not be very pleased with this so have a look at figures 1 and 2 to see where everything belongs before soldering any wires. The cassette recorder is more tolerant of wrong connections but it is far better if

the circuit works correctly first time. Again make sure to solder the right wires in the appropriate places. The layout usually used for a cassette recorder's DIN socket is illustrated in figure 3. The two terminals for the relay contacts (points R and S in figure 1) are linked to the recorder's remote input via a jack plug. If the tape recorder in question does not have any remote input this is no reason for panic; simply connect R and S in series in one of the voltage supply lines to the motor.

Installation and use

All the components must be fitted to the printed circuit board shown in figure 4 and when this is done a suitable case must be found for the circuit. Alternatively, it may be possible to include it within the cassette recorder case. Whichever of these is chosen there is one point to bear in mind: the connecting wires must not be made too long. A special connector is needed to link the interface to the computer's cassette input/output lines. This is a six-way printed circuit board connector with a spacing of 3.96 mm (0.156") between the pins. The wires can also be soldered directly onto the printed circuit board. We will be very brief in our instructions

3

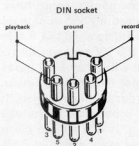

85010-3

Commodore cassette interface

Figure 3. Here is the arrangement most commonly used when a cassette recorder has a DIN socket for input/output.

on using the circuit: refer to page 18 of the C64 user's manual. The function of S1 in the circuit is clear. It is used to switch the motor on and off, which is very handy for winding the tape. If an error message is generated during loading the volume control on the cassette recorder is probably not correctly set. When reading tapes that you have not re-recorded yourself it may be necessary to re-align the record/playback head. If our experiences with this interface are anything to go by, however, errors will rarely occur, even when 'turbo' loading. **M**

4

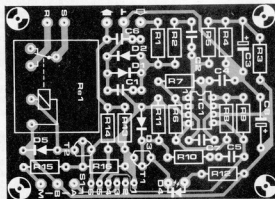
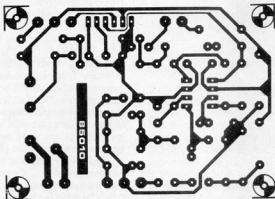

Parts list

Resistors:

- R1, R2 = 4k7
- R3, R4 = 2k2
- R5, R8 = 22 k
- R6, R11, R16 = 47 k
- R7, R10, R15 = 10 k
- R9 = 220 k
- R12 = 220 Ω
- R13 = 100 Ω
- R14 = 1k5

Capacitors:

- C1 = 10 n
- C2 = 22 n
- C3 = 22 μ /16 V
- C4...C7 = 100 n
- C8 = 10 μ /16 V

Semiconductors:

- D1, D2 = AA119
- D3, D5 = 1N4148
- D4 = LED
- T1, T2 = BC547B
- IC1 = LM387

Miscellaneous:

- Re1 = relay, 6 V PCB-mounting type *IMS Components* - part no. 8055)
- S1 = single-pole toggle switch
- 6-way PCB edge connector with pin spacing of 3.96 mm (0.156" - *Maplin*, order no. FG24B)

Figure 4. Constructing the circuit is simply a matter of assembling the components on this printed circuit board. Make sure no wires are switched when making the interconnections.

Computers, video games, video cameras, games computers; all of these produce video signals that must be displayed via a television set. If the TV receiver in question does not have a video input and its owner is reluctant to vandalise it in order to fit one then this sort of modulator is the obvious solution. It is a simple circuit that processes video signals to enable them to be fed straight into the TV set's aerial input.



VHF/UHF TV modulator

for any TV set
without a video
input

A 'TV modulator' is really no more than a transmitter. It is a very small transmitter, admittedly, but none the less that is what it is. What does a modulator actually do? In general — and this design is no exception to the rule — it is a simple oscillator that generates a frequency somewhere in the VHF or UHF region. The oscillator is modulated with the video signal and the modulated carrier wave thus generated is fed into the TV set's aerial input via a cable. Then all that remains to do is tune the TV to the correct frequency.

The layout

The whole business is not quite as simple as we have just suggested, of course, as the mini transmitter must meet certain requirements. The frequency stability must be very good as, indeed, must the quality of the display. The required frequency stability is achieved by the use of a crystal oscillator. A well thought out

choice of component values takes care of the display quality: the modulator allows a resolution of 80 characters per line, as this is a value that is often needed.

A very important feature of the circuit that must be decided is the transmission frequency. If this is only a single channel, as suggested above, it gives rise to some practical problems. Different users will want different channels, the carrier wave can become somewhat difficult to locate, and unless the frequency is exactly spot on no signal will be received. A much better idea is to ensure that the HF signal contains a large number of different frequencies. This makes it much easier to tune the TV set to one of the frequencies as there will surely be one to suit every user.

The block diagram of figure 1 shows how this is achieved. The TV modulator is made up of two parts, namely a modulatable crystal oscillator and a harmonics generator. The oscillator operates at a frequency of 27 MHz, which is quite low so inexpensive crystals are readily available. The harmonics generator converts the oscillator signal into a sort of frequency spectrum containing all the multiples of 27 MHz up to about 1800 MHz. The TV modulator's output signal is made up of a large number of little peaks, each of which is a complete transmitter signal. At least one of these will always be in band I (VHF channels 2...4), one in band III (VHF channels 5...12) and many of them will be in bands IV and V (UHF channels 21...69).

The circuit diagram

Like the block diagram, the circuit (shown in figure 2) is very straightforward. The crystal oscillator is based on a very fast HF transistor, T1 (BFR91), which performs the amplitude modulation. Apart from this there is little to be said about the oscillator except, perhaps, that it is essential to use the correct values for the components surrounding T1. This is, of course, simply common sense in this sort of HF circuit. The harmonics generator is formed by two Schottky diodes, D1 and D2. These diodes must switch very quickly in time with the 27 MHz signal so they provide strong harmonics up into the gigahertz range. The modulation depth can be set with P1, while the oscillator's d.c. value can be varied by means of P2. The combination of these two presets enables either positive or negative amplitude modulation to be selected. This is essential as the harmonics produced vary in this respect. We will discuss the calibration of P1 and P2 later in this article.

The power for the circuit can be provided by either an unstabilized 8...30 V or a stabilized 5 V. The latter could be taken from a computer's power supply and in this case IC1 is not needed.

Construction

The tiny printed circuit board designed for this circuit is shown in figure 3. It is

Figure 1. A TV modulator is, in fact, a small TV transmitter. In this case the transmitter consists of a modulatable (AM) oscillator followed by a harmonics generator.

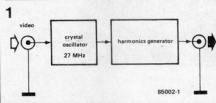

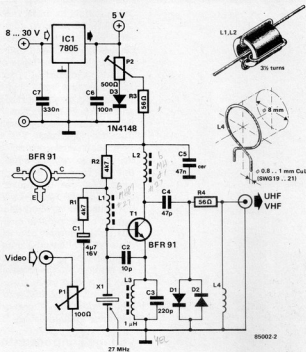

VHF/UHF TV modulator

Figure 2. In this circuit diagram we see that the 27 MHz oscillator is based on transistor T1 and the harmonics are generated by Schottky diodes D1 and D2.

Parts list

Resistors:

R1, R2 = 4k7
R3, R4 = 56 Ω
P1 = 100 Ω preset
P2 = 500 Ω preset

Capacitors:

C1 = 4.7/16 V
C2 = 10 p
C3 = 220 p
C4 = 47 p
C5 = 47 n, ceramic
C6 = 100 n*
C7 = 330 n*

Inductors:

L1, L2 = 3½ turns of 0.2 mm (SWG 35 or 36) CuL on a ferrite bead of about 3.5 × 3.5 mm
L3 = 1 μH
L4 = 1 turn of 0.8...1 mm (SWG 19...21) CuL, air-wound with a diameter of 8 mm

Semiconductors:

D1, D2 = 1N6263 (Ambit/Cirkitt)
D3 = 1N4148
T1 = BFR91 (Ambit/Cirkitt)
IC1 = 7805*

Miscellaneous:

X1 = crystal, 27 MHz^{3rd} overtone or other 3rd overtone crystal between 25 and 30 MHz

* = not needed if the circuit is powered from a stabilised 5 V supply

not double-sided as this was found to be unnecessary. Construction is thereby simplified and readers who do not buy the board through our EPS service (tut-tut) will find it easier to make themselves. Building the circuit is simply a matter of fitting the components onto the printed circuit board. The coils, often a source of much teeth-gnashing and hair-pulling, will not be a problem in this case. Two of them, L1 and L2, are made by winding 3½ turns of enamelled copper wire (about 0.2 mm thick) on a 3.5 mm ferrite bead. Another, L4, is just one turn of copper wire (0.8...1 mm thick) air-wound with a diameter of 8 mm. The fourth inductor, L3, can simply be bought.

Any third overtone crystal with a frequency of between 25 and 30 MHz will work in this circuit. A number of suitable values are advertised in this issue. The only parts that might prove difficult to find are diodes D1 and D2. The ones stated in the parts list are available at the moment but do not give up hope if your corner shop does not have them. The only important thing is that they must be UHF Schottky diodes; the actual type number is of little consequence.

Calibration

Calibrating the modulator calls for a certain degree of care as it involves more than just 'set the presets to mid-position'. The setting depends, in fact, on the harmonic to which the circuit is tuned. Calibration should be carried out as follows:

- Set the TV receiver to maximum brightness and contrast.
- Feed a video signal into the modulator (a video recording of a test card, or a link to a computer's 'TV' socket, could be used) and connect the circuit's output

3

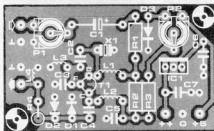
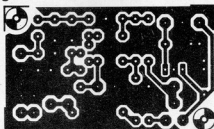

to the TV's aerial input.

- Set P2 to mid-position and P1 to minimum resistance (fully anti-clockwise).
- Tune the TV receiver to a harmonic, preferably one of the VHF bands (channels 2...12). The tuning is correct when the 'snow' on the screen disappears and/or the screen becomes dark.
- Turn P1 very slightly until 'something' becomes visible.
- Calibrate P2 to give the best possible quality image. If the result is not very good the wiper of P1 can be moved a bit more and P2 again trimmed to give a better image.
- If this still fails to provide an acceptable result tune the TV to the next harmonic. This must give a decent image.

Figure 3. Fortunately the printed circuit board for the modulator is only single-sided. The large copper surface acts as a ground plane.

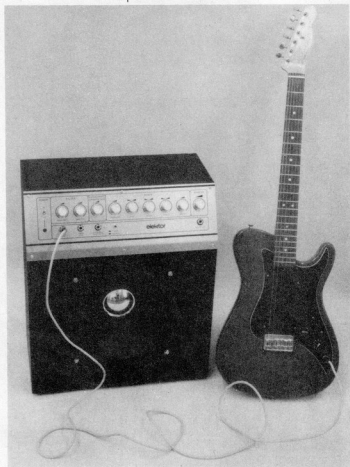

portable guitar amplifier

with a host of facilities

Apart from output power and the choice of valves or transistors as active elements, there is not much to distinguish the multitude of commercial guitar amplifiers on the market. All that most of them offer is a three-channel equalizer for bass, mid-range, and high frequencies, and a built-in reverberation spring: this does not give the musician much scope for experimentation. Yet, even for only a modest outlay it is possible to bring some colour to the monotony of the basic sound of the strings. This is made possible by a voltage-controlled filter — surely no stranger to our musical readers.

The controls for bass, mid-range, and high frequencies on most commercial guitar amplifiers may be compared with those on a hi-fi installation. Unfortunately, they do not change the basic character of the sounds produced by a guitar string: to do so, many more additional units are required: phaser, chorus, flanger, fuzz box, and so on. In many cases, these units really do mellow the harsh notes produced by the guitar. The amplifier described here does not, and is not intended to, replace such additional units entirely. However, several of the add-on units are based on similar principles and can be imitated fairly easily, and well, by the voltage-controlled filter on which the design of the present amplifier is based. Mixing the outputs of a voltage-controlled filter (VCF) allows the continuous transition from all pass to notch mode. Furthermore, the signal from the integral fuzz circuit may be added to the outputs of the VCF, so that with only four potentiometers a whole spectrum of tone colour variations becomes available.

Voltage-controlled filter (VCF)

The VCF is a simplified version of that used in the Formant synthesizer (that used in the Formant synthesizer (see *Elektron (UK)* December 1977, page 12-27). It is built from opamps A2, A3 and A4 as shown in figure 1, which function as high pass, band pass, and low pass filter respectively. Stereo potentiometer P3 enables the setting of a specific turnover point, that is, the centre frequency of the band pass filter.

Overdrive (fuzz) circuit

Either the direct or the filtered signal from the guitar may be fed to opamp A5 by switch S1. The gain of the amplifier can be set within wide limits by P2: this is vital because the stage following A5 needs a threshold to function as limiter and so provide the required amount of distortion. The use of three pairs of diodes results in a smoother onset of limiting, that is, a progressive increase in distortion, which provides a tone reminiscent of valve amplifiers. The operation of the overdrive circuit is clarified in figure 2.

Mixing

Potentiometers P6...P9 allow the mixing of the outputs of the filter and the distortion generator: the wipers of all four are connected to the inverting input of opamp A7. Preset P10 enables the setting of the required feedback factor: the higher its value, the greater the gain of A7.

Reverb(eration) unit

Reverberation springs have been a welcome addition to guitar amplifiers for a long time. Although they do not perform miracles, they add to the fullness of the sound. The principle on which they work is that the sounds to be reverberated are magnetically coupled to one or two metal

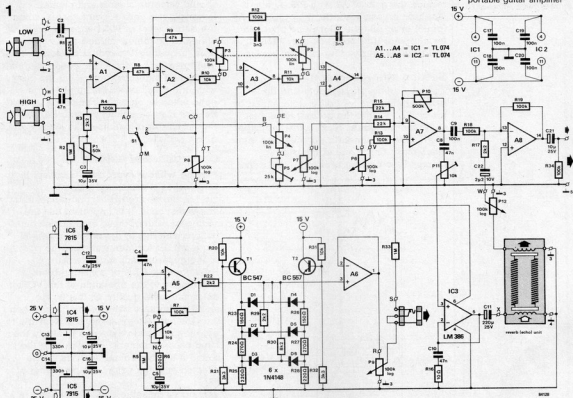

Figure 1. Circuit diagram of the pre-amplifier.

springs. Because of the elasticity of the springs, the mechanical waves to which the signals from the guitar have been converted take a certain time to reach the other side of the spring where they are reconverted to electrical signals. Integrated a.f. amplifier IC3 drives the input coil: a standard opamp would not be able to provide sufficient energy, that is, output current.

Opamp A8 is a mixer in which the direct and the reverberated signals are added together. Potentiometer P12 enables continuous adjustment of the level of the echo. The relatively low value of R17, compared with that of feedback resistor R19, provides a fiftyfold gain of the reverberated signal.

Calibration

The potentiometers are all brought out at the front panel and their setting will be discussed under 'operation and setting up'.

Depending on the type of pick-up used, the peak value of the signals produced by an electric guitar vary widely. Preset P1 determines the gain of input amplifier A1. To start with, set the wiper of this control to the centre of its travel. Then connect the output of A1 (pin 7) to the output amplifier, and connect an electric guitar to the input of the circuit. If the 30-watt a.f. output stage described elsewhere in this issue is used, set the potentiometer, P13, between A1 and that amplifier to maximum. Also, set the volume control on the guitar to maximum.

The maximum required volume can now be set with P10, but only after P6...P8 have been turned open (wipers at output of opamps A4, A3, and A2 respectively), P3 and P4 have been set to the centre of their travel, and P9 and P12 so that their wipers are at earth potential. The setting of P2 is immaterial. When all this is done, the basic sound of the guitar, without distortion and reverberation, should be heard in the loudspeaker. If the sound is distorted, it probably means that A1 is overloaded. The remedy is to reduce its gain with P1. If you have an oscilloscope, check that the signals at the output (pin 7) of A1 are not being limited.

It may also be that the output stage is overloaded; in that case, reduce its gain with P13 until the sound is fairly soft. If there is still distortion, A7 or A8 may be overloaded; the remedy for this is to

2

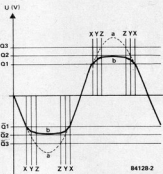

Figure 2. A clean sine wave (a) at the input of the overdrive (fuzz) circuit appears flattened (b) at the output if its peak value is equal to, or exceeds, the thresholds, Q1...Q3, of the three pairs of limiting diodes. At x the first diode pair starts to conduct, at y, the second also, and at z all diodes conduct.

reduce the gain of A7 with P10. Again, if you have an oscilloscope, the output of A7 (pin 8) or of A8 (pin 14) may be checked for clipping. It is, however, very unlikely that there is overloading of these stages.

Setting the reverberation

The level of the signal applied to the reverberation exciter coil is determined by preset P11. To find the correct level, first set P12 to maximum. Next, move the wiper of P11 slowly from earth potential and simultaneously pluck one of the guitar strings. If everything is all right, the echo

should become clearer and clearer. However, at a certain point, that is, when the output level of IC3 becomes too high, the echo becomes muffled and suffers from frequency-dependent distortion. To avoid this happening even when the guitar is plucked vigorously, carry out this test with firm plucking of the string. If the echo is too weak with P11 and P12 at maximum, it may be enhanced with P10, even though this also increases the level of the direct signal.

Operation and setting up

Playing without overdrive (fuzz): set P9 to zero (wiper at earth) and with P6...P8 choose the desired bass, mid-range, and treble response. It is important that the setting of each of these controls is compatible with that of the others. When all three are set for identical gain, the output of the guitar sounds virtually natural. Potentiometer P4 is of considerable importance to the operation of the VCF: it determines the quality, Q, that is, the slope of the pass band of the filter. When the Q is high (steep slope) it is possible to produce artificial resonance peaks in the band-pass characteristic which give the sound a distinct colouring. This is also affected to some extent by the setting of P3.

Varying P3 (imagine this control fitted in a foot-operated swell) with Q high and only the low-pass filter section operating causes a wa-wa effect. With a low Q and the mid-range frequencies attenuated, slowly altering the crossover frequency gives rise to a phasing effect.

When the wiper of P4 is at earth potential, the VCF functions as an oscillator and it is therefore necessary that P5 is adjusted so that with maximum Q the filter just does not oscillate.

Playing with overdrive (fuzz): when switch S1 is in position 1, the entire sound from the guitar becomes overdriven.

Unlike many other guitar amplifiers, the present one allows the continuous mixing of the original and overdriven sounds: this may be arranged by a foot switch connected to jack socket S (see figure 1). If only the overdriven sound is wanted, potentiometers P6...P8 must be turned off completely (wipers at earth).

The degree of overdrive may be set with P2 to individual taste.

When S1 is in position 2, only those frequencies that lie above the crossover point set by P3 will be overdriven. If you mix the fuzzy high frequencies with the original low ones, a very pleasant, hoarse sound ensues that cannot be produced by a traditional fuzz box (see figure 3).

Because of space considerations, we cannot describe all possible sound variations, but hope that the examples given will spur you on to further experimentation.

Power output stage

A low-weight, portable guitar amplifier of modest dimensions requires a power output stage that is small, reliable, efficient,

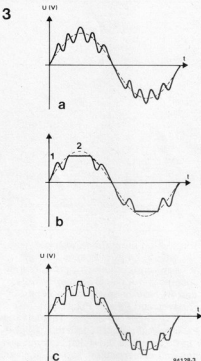

Figure 3. If a composite signal (a) is distorted through limiting, the higher frequencies may be chopped (b, 2) or not be affected at all (b, 1). A more pleasant sound ensues if first only the high frequencies are limited and then superimposed onto the lower ones (c).

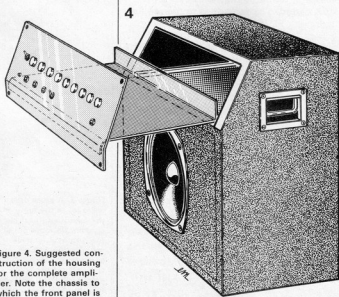
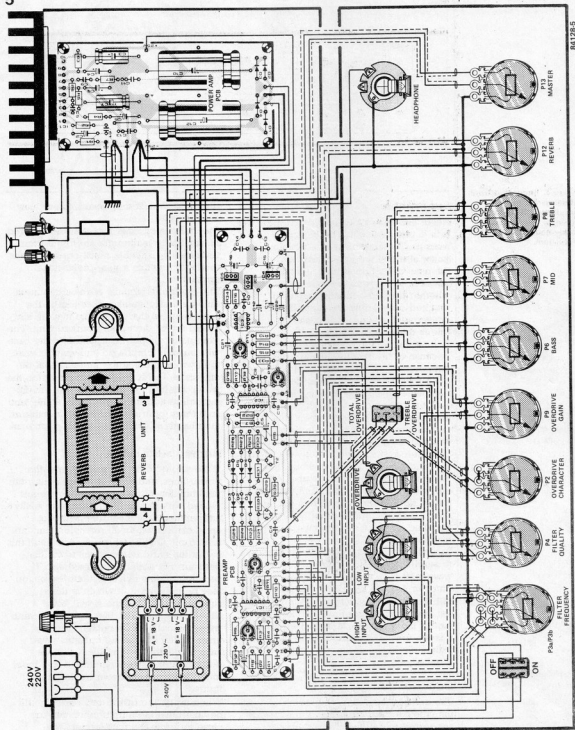

Figure 4. Suggested construction of the housing for the complete amplifier. Note the chassis to which the front panel is fixed: the whole may conveniently be slid into and out of the case.



and yet provides sufficient power to prevent the audience reaching for their hearing aids! To cut a long story short, we have opted for the 30-watt output stage described elsewhere in this issue. The complete set-up gave very satisfactory results during tests and operation in small to medium-sized halls; it would probably not be quite suitable for use in larger spaces.

Power supply

Power for the pre-amplifier is derived from the supply of the 30-watt output stage: the printed circuit of that stage is already fitted with appropriate take-off terminals. If you do not use the 30-watt output stage, you need a supply that is capable of providing $\pm 18 \dots \pm 25 \text{ V}$ at 35 mA (positive line) and 22 mA (negative line).

Figure 5. View of the top of the chassis and the rear of the front panel. It is important to adhere to the wiring layout to prevent earth loops. Do not forget to insulate all sockets from the front panel!

All dashed lines indicate screened cables. Screens must only be connected to earth where shown or at the front panel.

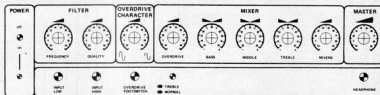

84128 6

Figure 6. Suggested front panel of the guitar amplifier. It is, unfortunately, not available ready-made from Elektor Publishers.

Loudspeaker

Never use a loudspeaker designed for use in hi-fi installations for the following reasons. The amplitude of a vibrating guitar string is not particularly large: in the case of the top strings, it is hardly possible to see with the naked eye whether they are vibrating, especially if plucked only lightly. The amplification consequently required to make them audible is quite considerable.

If, however, a string is plucked vigorously, because of the type of music or the temperament of the player, it is deflected quite a distance from its rest position. The instantaneous voltage then induced in the pick-up coil reaches a very high peak and, in modern hi-fi equipment, this is faithfully transferred to the loudspeaker which in consequence may easily be damaged or destroyed. Fortunately, there are loudspeakers available which have been specially designed for use with electric guitars. They are characterized by a very rigid suspension of the cone and their ability to cope with the wide dynamic range of electric musical instruments.

Basically, the loudspeaker should be able to handle not less than 50 watts (sine wave) and have an input impedance of 8 ohms or 4 ohms. Note that mid-range and treble speakers are not just superfluous but unwanted! After all, we are not looking for linear transfer of the guitar sounds: it is the unfaithful reproduction that makes the music of electric guitars so popular!

Construction

The complete amplifier, including loudspeaker, may be housed in a case as suggested in figure 4. The shape corresponds closely to current market trends. Dimensions are primarily dependent upon the loudspeaker: unfortunately, we have not been able to find a suitable speaker that would make it possible to house the amplifier in a truly portable case.

The top compartment of the wooden case offers ample space for the pre-amplifier, output stage, and power supply.

The best material to use is 19 mm (¾ inch) chipboard. The various panels should be fastened together with dowels and wood

glue: if you must, chipboard screws may also be used.

The completed case may then be covered in, say, black leatherette and the corners protected by suitable metal corner pieces to give the whole a near-professional appearance.

The electronic circuits are best mounted onto a chassis which is fastened to the front panel so that the whole may be slid in and out of the upper compartment. The front panel should be fastened to the case with suitable chipboard screws. It is wise to fit two runners at the underside of the chassis so that it does not lie direct on the wood: this has the advantage that any fixing screws for the transformers, PCBs, and so on may protrude from the underside of the chassis without causing any problems.

Some useful hints

If the wiring to the potentiometers, the power lines, and the wires connecting the pre-amplifier to the output stage are not placed with careful thought, it may easily happen that hum is audible from the speaker even when all potentiometers are turned off. One of the prime causes of this is that the earth connections to various parts are not radial but form a loop. If such a loop lies in a stray field, a voltage may be induced in it which is then superimposed onto the signal. Care should also be taken that signal paths and wires (including PCB tracks) carrying unsmoothed alternating currents never have a common return. It is for these reasons strongly recommended to adhere to the interconnection wiring layout in figure 5.

When fitting the reverb unit, care should be taken that the output coil is not too close to the mains transformer. The screened housing of the unit does not offer all that much protection against the strong electro-magnetic field existing in the immediate vicinity of the transformer. It is also best not to fit the unit rigidly to the chassis to prevent any mechanical vibrations from the loudspeaker and mains transformer being transferred to it. This is easily accomplished with a felt washer fitted between the chassis and the unit housing: it is wise to glue the washer in place.

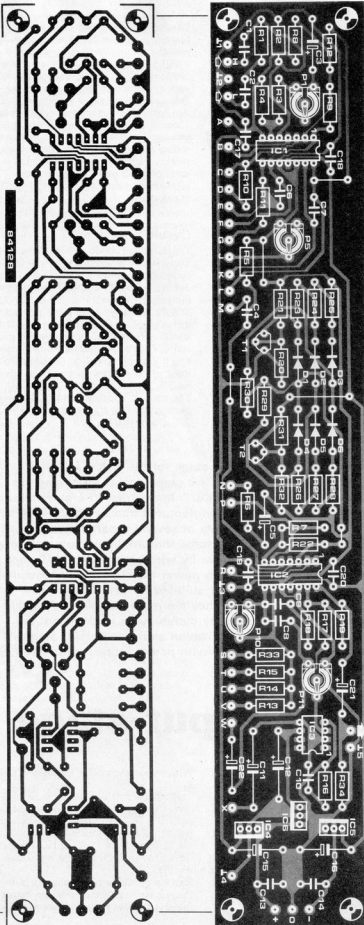

portable guitar amplifier

Parts list**Resistors:**

R1 = 470 k
 R2, R5, R33 = 1 M
 R3, R17, R22, R29 = 2k2
 R4, R7, R12, R13, R18, R19,
 R34 = 100 k
 R6, R25, R28 = 220 Ω
 R8, R9 = 47 k
 R10, R11, R20, R31 = 10 k
 R14, R15 = 22 k
 R16 = 10 Ω
 R21, R32 = 3k3
 R23, R26 = 150 Ω
 R24, R27 = 270 Ω
 R30 = 8k2
 P1 = 50 k preset, PCB type
 P2 = 10 k potentiometer,
 log.
 P3 = 100 k potentiometer,
 stereo, lin.
 P4 = 100 k potentiometer,
 lin.
 P5 = 25 k preset, PCB type
 P6, P7, P8, P9, P12 = 100 k
 potentiometer, log.
 P10 = 500 k preset, PCB
 type
 P11 = 10 k preset, PCB
 type

Capacitors:

C1, C2, C4, C8, C10 = 47 n
 C3, C5, C15, C16,
 C21 = 10 μ /35 V
 C6, C7 = 3n3
 C9, C17, C18, C19,
 C20 = 100 n
 C11 = 220 μ /25 V
 C12 = 47 μ /25 V
 C13, C14 = 330 n
 C22 = 2 μ /10 V

Semiconductors:

D1...D6 = 1N4148
 T1 = BC 547
 T2 = BC 557
 IC1, IC2 = TL 074 (TL 084)
 IC3 = LM 386
 IC4, IC6 = 7815
 IC5 = 7915

Miscellaneous:

S1 = SPST switch
 2 jack socket, 6.3 mm,
 mono, without switch
 1 jack socket, 6.3 mm,
 mono, with switch
 printed circuit board 84128

Figure 7. The printed circuit of the pre-amplifier.

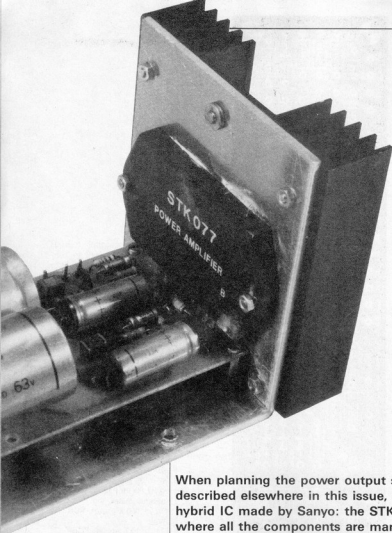

The input of the device is formed by differential amplifier T2/T3 whose emitter resistance consists of current source T1/D1/D2. The output of the amplifier is fed to driver T6 whose collector resistance is formed by current source T4. Transistor T5 provides a constant bias voltage for the output transistors: the bias allows a quiescent current of about 50 mA through these transistors. The output transistors are arranged as quasi-complementary darlington: T7 and T9 form an n-p-n darlington; T8 and T10 are the complementary pair. Any asymmetry of T8/T10 is negated by diode D5.

Circuit description

The amplifier circuit, shown in figure 2, is designed for operation from a $\pm 25\text{ V}$ symmetrical power supply. The full 50 V, decoupled by C4 and C8, is applied to the output transistors, pins 6 and 8, in the STK077. The supply for the input and driver stages is decoupled by R3/C3 and R5/C7 respectively and applied to pins 10 and 4. Feedback is arranged by connecting the output, pin 7, to the inverting input of the differential amplifier, pin 3, via R6.

The gain, A, is determined by the feedback factor, that is, the ratio $R6/R4 - A = (R6 + R4)/R4$.

When planning the power output stage for the guitar amplifier described elsewhere in this issue, we came across an interesting hybrid IC made by Sanyo: the STK077. In contrast to a monolithic IC where all the components are manufactured into or on top of a single chip of silicon, a hybrid IC consists of several separate component parts, attached to a ceramic substrate, that are interconnected by an appropriate metallization pattern or by wire bonds. Hybrid ICs are frequently encountered in medium power (30...60 W) hi-fi equipment. They are, however, also eminently suitable for use in home-constructed amplifiers, because they are more reliable and smaller than circuits built up from discrete components, and are not so vulnerable and susceptible to oscillation as monolithic IC stages. Hybrid ICs are generally available with power ratings up to 70 W and are normally reasonably priced.

30 watt a.f. output stage

based on a new hybrid IC

The STK077 is a 30 watt hybrid IC that is ideal for use in small mono a.f. amplifiers or medium power stereo equipment. It is also of interest to those who want a small amplifier for fitting into an active loudspeaker box.

The innards of the STK077 form a fairly conventional a.f. amplifier circuit as can be seen from figure 1. Note that the power transistors are mounted direct on the cooling area of the device to ensure better heat dissipation.

With values shown this amounts to nearly 27 dB.

The input signal is applied to the non-inverting input (pin 1) of the differential amplifier. DC zero potential is ensured by resistor R2, which carries the base current for T2. Pin 2 is the earth terminal which is internally connected to the metal base of the STK077.

Stability of the output transistors is arranged by various methods. On board there is a Miller capacitor between base

and collector of driver T6, while externally capacitor C5 is connected between pins 3 and 5. Capacitor C9 and resistor R7 at the output, pin 7, ensure a defined load at high frequencies and this enhances the stability under no-load conditions. Finally, the input has been provided with an RC low-pass filter (R1/C1) which increases the rise time of the input signal and so reduces the transient intermodulation distortion (TIM).

The power supply, with the exception of the mains transformer, is housed on the same printed circuit as the amplifier. It consists of an unregulated circuit: four standard diode rectifiers, and two electrolytic smoothing capacitors each shunted by a foil capacitor.

When a mains transformer with 2 x 18 V secondary is used, the direct output voltage under no-load conditions is of the order of 25 V, falling to about 22 V when a normal load is connected. A 1 A transformer can be used for output powers up to 20 W.

More power

With a ± 20 V power supply, the STK077 provides 20 watts into 8 ohms, or 30 watts into 4 ohms. In the latter case, both the third harmonic distortion and the current consumption are somewhat higher than in the former. If you want higher power, one of the series STK078...STK083 may be used: the printed circuit board remains unchanged, but it is, of course, necessary to use an appropriate mains transformer and higher rated electrolytic capacitors. Data for these are given in table 2.

Practical tips

The mains transformer may have a single centre-tapped secondary or two separate windings. In the latter case, proceed as follows: connect one of the terminals of secondary 1 with one of secondary 2 and measure the a.c. voltage between the two free terminals. If this is 0 V, the terminals of ONE of the secondaries must be changed over so that across the free terminals an a.c. voltage of twice the rating of one of the secondaries is measured. The interconnected terminals become the equivalent of the centre tap which is connected to earth as shown in figure 2.

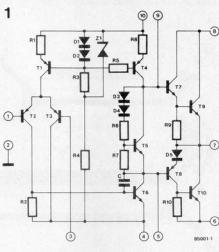

30 watt a.f. output stage

Figure 1. The circuit of the STK077. Note that the power transistors are connected in a quasi-complementary darlington arrangement.

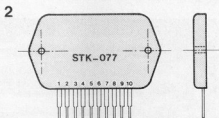
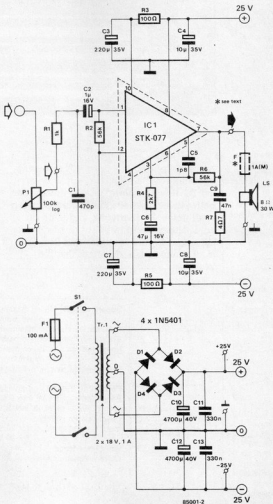

Figure 2. Circuit diagram of the amplifier and its unregulated, symmetrical power supply.



Parts list

Resistors:

R1 = 1 k
 R2, R6 = 56 k
 R3, R5 = 100 Ω
 R4 = 2k7
 R7 = 4k27
 P1 = 100 k logarithmic potentiometer

Capacitors:

C1 = 470 p
 C2 = 1 μ /16 V
 C3, C7 = 220 μ /35 V
 C4, C8 = 10 μ /35 V
 C5 = 1p8
 C6 = 47 μ /16 V
 C9 = 47 n
 C10, C12 = 4700 μ /40 V
 C11, C13 = 330 n

Semiconductors:

D1...D4 = 1N5401
 IC1 = STK077 (or STK078...STK083)

Miscellaneous:

S1 = DPST mains switch
 Tr1 = mains transformer, secondary 2 \times 18 V/1 A
 F1 = fuse, 100 mA, slow blow
 F2 = 1 A (8 Ω loudspeaker) or 1.6 A (4 Ω loudspeaker) slow blow (2 seconds)
 Heat sink — temperature rise 1.7 K/W
 Printed circuit board 85001

Figure 3. The printed circuit board is not only for use with the STK077 but also with other members of the family, STK078...STK083, which give output powers of not less than 24...40 watt into 8 ohms, depending on which member is used.

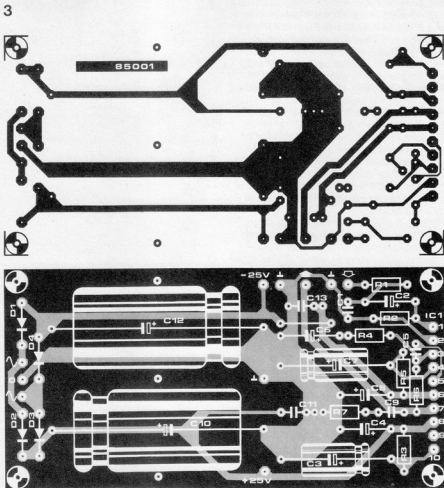

Failure of one of the power lines during operation of the amplifier would destroy the IC. It is, therefore, vital to ensure that both power lines are connected properly at all times. Furthermore, under no circumstances should either the positive or the negative line be protected by a fuse. It is, of course, also important that the

voltages across the two secondaries as well as capacitors C10 and C12 are identical.

The value of the thermal rating of the heat sink stated in the parts list and table 2 applies to the amplifier being driven hard. If the amplifier is intended for domestic (music) use only, the value may be

Table 1

| | |
|--|-----------------|
| Supply voltage, U_b — maximum | \pm 32 volts |
| — recommended | \pm 22 volts |
| Case temperature — maximum | 85°C |
| Short-circuit duration — maximum | 2 seconds |
| Load resistance — recommended | 8 ohms |
| — minimum | 4 ohms |
| Quiescent current — maximum | 100 mA |
| — typical | 50 mA |
| Power into 8 ohms — minimum* | 20 watts |
| Bandwidth — at 1 W into 8 Ω | 10 Hz...100 kHz |
| — at 20 W into 8 Ω | 10 Hz...30 kHz |
| Output direct voltage — maximum | \pm 70 mV |
| Input voltage (rms) — for 20 W into 8 Ω | 600 mV |
| — for 30 W into 4 Ω | 500 mV |
| Input impedance | 50 kilohms |
| Current consumption — at 20 W into 8 Ω | 1 A |
| — at 30 W into 4 Ω | 1.5 A |

* in range 20 Hz...20 kHz, THD = 0.3%, $U_b = \pm 22$ V

Table 1. Brief technical characteristics of the STK077.

somewhat lower. It may be useful to drill out the fixing holes in the heat sink slightly to avoid mechanical stress during its installation. The use of silicone heat transferring grease is strongly recommended.

If the amplifier is used for mono applications, a fuse may be fitted in the loudspeaker lead: this is shown in dashed lines in figure 2. The fuse should be of the medium-slow (about 2 seconds) type. Values for use with other ICs in the series are given in table 2.

The heat sink and printed circuit board should be fixed to a chassis with the aid of an aluminium angle piece as shown in figure 4, since the terminals of the IC cannot support the PCB.

As always in a.f. amplifiers, the wiring layout should be thought out carefully. On the premiss that any wires may cause problems, we reduced the amount of wiring by designing the power supply and the amplifier on one PCB. The only wires consequently required are three to the mains transformer, two to the loudspeaker, and a screened one for the input signal.

If two amplifiers are built for stereo applications, it is possible to use one mains transformer of twice the rating stated in the parts list. Separate power lines should then be connected to each of the PCBs. Separate earth return lines for each loudspeaker are also required: this means that each PCB is connected to the appropriate loudspeaker by a two-core cable.

If you want to use a 4-ohm loudspeaker, the mains transformer should be capable of providing a secondary current of 1.5 A: alternatively, a transformer with lower secondary voltage ($2 \times 15 \dots 16$ V) may be used. The heat sink should also be adapted to the higher dissipation, for instance, 1.5 K/W instead of 1.7 K/W. The only other difference between the 4-ohm and 8-ohm versions is that the former has a slightly higher third harmonic distortion (THD) factor than the latter, as shown in figure 5.

Table 2

| | STK078 | STK080 | STK082 | STK083 |
|--|-----------------|---------------|---------------|---------------|
| Supply voltage — max. | V ± 35 | ± 39 | ± 43 | ± 46 |
| — recommended | V ± 25 | ± 27 | ± 30 | ± 32 |
| Load resistance | | | | |
| — recommended | Ω 8 | 8 | 8 | 8 |
| Output power into 8 Ω | | | | |
| — minimum | W 24 | 30 | 35 | 40 |
| Secondary transformer | | | | |
| voltage — recommended | V 2×20 | 2×22 | 2×25 | 2×27 |
| Transformer rating | | | | |
| — recommended | VA ≥ 50 | ≥ 60 | ≥ 75 | ≥ 90 |
| Rating of electrolytic capacitors (C3, C4, C7, C8, C10, C12) | V 35/40 | ≥ 50 | ≥ 50 | ≥ 50 |
| Fuse rating (8-ohm loudspeaker) | A 1.2 | 1.6 | 1.6 | 2 |
| Heat sink — temperature rise | K/W ≤ 1.5 | ≤ 1.4 | ≤ 1.2 | ≤ 1 |

Table 2. Variations in ratings if higher power ICs from the STK series are used.

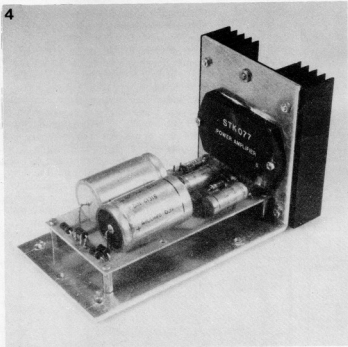

Figure 4. To avoid mechanical strain on the IC terminals, the printed circuit board, heat sink, and IC should be fitted together as shown.

5

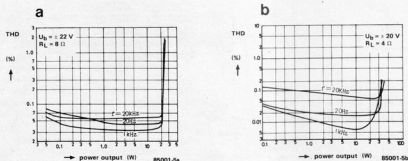

Figure 5. Third harmonic distortion vs output power in the STK077: in 5a with 8-ohm load and ± 22 V supply; in 5b with 4-ohm load and ± 20 V supply.

Whenever two (or more) large programs must exist at the same time in a 6502's memory there is bound to be a conflict as regards page 0 and the stack (page 1). The situation could arise if a BASIC interpreter and a DOS (disk operating system), or both of these and a video handler, are being used simultaneously. One of the accepted methods of solving this problem involves reserving two areas in random access memory where these pages are 'duplicated', giving, for example, E000...E0FF for page 0 and E100...E1FF for the stack. Every time the computer changes from one program to the other the contents of these areas of RAM are swapped with the appropriate contents of pages 0 and 1. This removes any possibility of corrupting the pointers on page zero or the contents of the stack.

JSR SWAP

software to interchange pages 0 and 1 in a 6502-based system

Table 1. The processor leaves the SWAP routine (which it entered using JSR) not by RTS but by JSR! The return address is 'stacked' at the start of the routine, then corrected (return address = address left + 1) and then placed after the jump instruction identified by the label JMPINS.

One of the notable characteristics of the 6502 microprocessor is the way it uses pages 0 and 1. The 256 bytes from 0000HEX to 00FFHEX can be addressed using commands specific to this zone. This is known as page zero addressing; the most significant address byte is not specified as it is implicit in the operation code. The same 256 bytes can be used as 16-bit pointers for indirect indexed addressing of the rest of the memory. The 256 bytes from 0100HEX to 01FFHEX form the 6502's stack. This is a register generated by the processor itself to enable it to store certain information. It operates on the principle of 'last in first out' so the processor can only work with the last item stored on the stack. An internal stack pointer continually indicates the address of this last item. It is obvious that the slightest careless

change of the parameters saved on these two pages will upset the operation of a program that is being run — usually with no possibility of correcting the error.

When two programs are run in parallel it is essential that they do not destroy each other's page 0 and 1 parameters. This is an extra worry for the programmer, particularly as it can be an insoluble problem. As soon as the programs that are being run reach a certain size it is better to find a way to break away from the shackles governing the use of pages 0 and 1.

The routine proposed here is used to move the contents of page zero and page one to another area of RAM where they can be changed at will. At the same time the contents of the RAM area in question is transferred to pages 0 and 1. The name of the routine is SWAP, for obvious reasons.

Using this routine means that the programmer no longer has to worry about the contents of pages zero and one when leaving one program to carry out another. All he has to do is run the SWAP routine. Page zero (0000HEX...00FFHEX) and page one (0100HEX...01FFHEX) of the first program are saved at E000HEX...E1FFHEX, and the contents of pages 0 and 1 for the second program, which had been stored at E000HEX...E1FFHEX, are transferred to 0000HEX...01FFHEX. When returning from the second to the first program the SWAP routine is again executed and the same procedure is carried out again to return the two pairs of pages zero and one to their original locations. The locations we have used to store pages 0 and 1 (E000HEX...E1FFHEX) can, of course, be changed to suit the system with which the SWAP routine is used, provided the area reserved is in random access memory. Similarly the SWAP routine itself must be run in RAM. A look at the last line of the listing will show why this is necessary. Indexing and swapping are the two procedures that make this routine possible so bear this in mind.

| | | | | | |
|------------------------|--------|------|--------|------------------------------------|--|
| 0040: | XXXXXX | | | | |
| 0050: | XSWAPX | | | | |
| 0060: | XXXXXX | | | | |
| 0070: | | | | | |
| 0080: | | | | | |
| 0090: | | | | | |
| 0100: | | | | | |
| 0110: | | | | | |
| 0120: | | | | | |
| 0130: E200 | PZ | X | 40000 | PAGE ZERO | |
| 0140: E200 | STACK | X | 00100 | STACK AREA | |
| 0150: E200 | SPZ | X | E0000 | SWAPPED PAGE ZERO | |
| 0160: E200 | SSTACK | X | 0E100 | SWAPPED STACK AREA | |
| 0170: | | | | | |
| 0180: | | | | | |
| 0190: | | | | | |
| 0200: E200 18 | SWAP | CLC | | | |
| 0210: E201 68 | | PLA | | | |
| 0220: E202 69 01 | | ADCM | 001 | PUT RETURN ADDRESS | |
| 0230: E204 80 2C E2 | | STA | JMPINS | +01 JUST BEHIND A JUMP OP-CODE | |
| 0240: E207 68 | | PLA | | | |
| 0250: E208 0A | | INX | | | |
| 0260: E209 98 01 | | BCC | SH | | |
| 0270: E20B E8 | | INX | | | |
| 0280: | | | | | |
| 0290: E20C 9E 2D E2 SH | | STX | JMPINS | +02 | |
| 0300: E20F A2 00 | | LDMX | 000 | RESET INDEX | |
| 0310: | | | | | |
| 0320: E211 8D 00 01 | SWAPST | LDAX | STACK | GET BYTE FROM PAGE 1 | |
| 0330: E214 BC 00 E1 | | LDYX | SSTACK | GET BYTE FROM SWAP AREA | |
| 0340: E217 9D 00 E1 | | STAX | SSTACK | SAVE BYTE FROM PAGE 1 IN SWAP AREA | |
| 0350: E21A 98 | | TYA | | | |
| 0360: E21B 9D 00 01 | | STAX | STACK | SAVE BYTE FROM SWAP AREA IN PAGE 1 | |
| 0370: E21E 95 00 | | LDAX | PZ | GET BYTE FROM PAGE 0 | |
| 0380: E220 BC 00 E0 | | LDYX | SPZ | GET BYTE FROM SWAP AREA | |
| 0390: E223 9D 00 E0 | | STAX | SPZ | SAVE BYTE FROM PAGE 0 IN SWAP AREA | |
| 0400: E226 74 00 | | STYX | PZ | SAVE BYTE FROM SWAP AREA IN PAGE 0 | |
| 0410: E229 C8 | | INX | | RUMP THE OFFSET | |
| 0420: E229 D8 E6 | | BNE | SWAPST | NOT DONE, KEEP ON | |
| 0430: | | | | | |
| 0440: E22B 4C FF FF | JMPINS | JMP | 4FFF | SELF MODIFYING CODE!!! | |
| 0450: | | | | | |

BASIC (PART 3)

Most of the principles involved in programming in BASIC have already been discussed. Most of the remaining BASIC statements will now be explained.

Having studied this third part of the series, it should be possible to write even fairly complicated programs; the last part of the series will deal with trouble-shooting in programs ('de-bugging').

There are several ways to enter data into a computer. If something is to be calculated, the 'data' usually consists of numbers. In Part 2, these were entered by assigning values to variables or by entering the numbers as part of the program. However, a different approach will often prove more useful in practice, using either of two further BASIC statements: INPUT and READ . . . DATA . . .

INPUT

By using the INPUT statement, data can be entered while the program is running. Or, to be more precise: when the computer finds an INPUT statement in the program, it stops and waits for the data to be entered before continuing with the program. The complete statement consists of 'INPUT' followed by the name of a variable. For example:

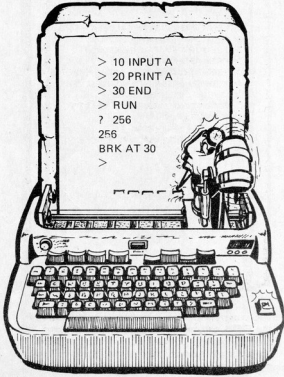

```
> 10 INPUT A
> 20 PRINT A
> 30 END
> RUN
? 256
256
BRK AT 30
>
```

When running the program, the computer prints a question mark as soon as it finds the INPUT statement on line 10. It then waits until a number is entered, followed by the CR key. As soon as the number '256' was entered, this value was assigned to the variable A — after which the rest of the program could be carried out.

The same statement can be used to assign values to several variables at the same time: 'INPUT A, B, C, . . .'. When the question mark is printed, all corresponding numbers must be entered: '? 123, 62, 23, . . .'. The INPUT statement can also be used to enter text variables, as will be explained in Part 4. The advantage of using the INPUT statement is that it opens the possibility of dialogue with the computer. Depending on intermediate results, for instance, the program can be re-run with new values until a desired final result is achieved. For instance, let us assume that we wish to know the returns after a certain number of years (N) from a personal investment (I) at various interest percentages (P). The final value (F) is equal to:

$$F = I \times \left(1 + \frac{P}{100}\right)^N.$$

In BASIC, this becomes:

$$F = I * (1 + P/100) \uparrow N.$$

A suitable program is therefore as follows:

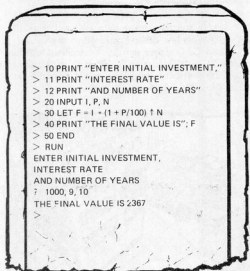

```
> 10 PRINT "ENTER INITIAL INVESTMENT,"
> 11 PRINT "INTEREST RATE"
> 12 PRINT "AND NUMBER OF YEARS"
> 20 INPUT I, P, N
> 30 LET F = I * (1 + P/100) \uparrow N
> 40 PRINT "THE FINAL VALUE IS"; F
> 50 END
> RUN
ENTER INITIAL INVESTMENT,
INTEREST RATE
AND NUMBER OF YEARS
? 1000, 9, 10
THE FINAL VALUE IS 2367
>
```

In other words, with an initial investment of £ 1000 and a 9% interest rate, the final value after 10 years will be £ 2367.

READ . . . DATA . . .

Another way of entering data is the use of so-called 'data blocks'. A data block is a group of data, preceded by the DATA statement; the various numbers and/or texts are separated by comma's. A

BASIC (PART 3)

data block is usually located at the end of a program; it is entered prior to running the program. In the main program, READ statements are used to recall the data as required; each new READ statement causes the next number, text or group of data to be recalled. For example:

```
> 10 READ A, B, C
> 20 D = A * B * C
> 30 READ E
> 40 F = D/E
> 50 PRINT D, F
> 60 DATA 1, 2, 3, 3
> 70 END
> RUN
6 2
BRK AT 70
>
```

In line 10, the first three data are read from the data block on line 60 and assigned to the variables A, B and C. In other words, A becomes 1, B becomes 2 and C becomes 3. Then D is calculated (line 20); the next number is recalled from the data block (line 30: E becomes 3); and so on.



As can be seen, several READ statements can be used — the data will be read out consecutively. Similarly, several DATA statements can be used; however, there is little point in this — they are simply used in consecutive order — and it makes it more difficult to locate and modify the data at a later date.

Obviously, it is important that enough data is stored in the data block. If, after reading the last of the data, the program encounters a further

READ statement, it will print some comment on the lines of 'OUT OF DATA IN xxx' (where 'xxx' is the line number of the READ statement where the data block proved to be empty).

In some BASIC dialects, the same data block contents can be re-used several times: the RESTORE statement causes the computer to start again at the beginning of the block.

The READ . . . DATA . . . statements are not known in NIBL.

REM

The REM statement (for 'REMark') is used to add explanatory text to the program, as an aid to the programmer. The text is simply entered after the REM statement; it will be ignored by the interpreter, but will reappear when a LIST command is given.

This statement will prove its value when a program has not been used for some time: it serves as a quick reminder of the meaning of variables, the importance of sections of program, etc. For example, in the 'personal investment' program given above:

```
> 1 REM THIS PROGRAM CALCULATES
> 2 REM THE FINAL VALUE F
> 3 REM OF AN INITIAL INVESTMENT I
> 4 REM AFTER N YEARS
> 5 REM AT AN INTEREST RATE OF P PERCENT
> 10 PRINT "ENTER INITIAL INVESTMENT,"
> 11 PRINT "INTEREST RATE"
> 12 PRINT "AND NUMBER OF YEARS"
> 20 INPUT I, P, N
> 30 LET F = I * (1 + P/100) ↑ N
> 40 PRINT "THE FINAL VALUE IS": F
> 50 END
```

(etc.)

The program itself is not affected in any way by the REM statements; they only reappear when a program listing is requested. They do, of course, use up some memory space — but there will normally be sufficient memory available.

BASIC (PART 3)

Standard functions

To simplify programming in BASIC, 10 standard mathematical functions are available:

| standard function | description |
|-------------------|---|
| SIN(X) | sine x |
| COS(X) | cosine x |
| TAN(X) | tangent x |
| ATN(X) | arctangent x. |
| EXP(X) | e^x ($e = 2.71828 \dots$). |
| ABS(X) | $ x $, the absolute value of x. |
| LOG(X) | $\log x = \ln x $, the natural logarithm. |
| SQR(X) | $\sqrt{ x }$, the square root of $ x $. |
| INT(X) | the integer of x. |
| SGN(X) | the 'sign' of x: $\begin{cases} 1 & \text{if } x \text{ is positive,} \\ -1 & \text{if } x \text{ is negative,} \\ 0 & \text{if } x \text{ is zero.} \end{cases}$ |

Note that for the sine, cosine and tangent functions the angle must be expressed in radians ($1 \text{ rad.} = 57.2958^\circ$, or $1^\circ = 0.017483 \text{ rad.}$); for the arctangent function, the result will be expressed in radians. The LOG (natural logarithm) and SQR (square root) functions automatically take the absolute value of x, without giving an error indication. For instance: $\text{SQR}(-4) = 2$.

The INT (integer) function sometimes causes confusion. It produces the largest whole number that is smaller than or equal to x. For positive numbers, this simply means omitting the decimal fraction: $\text{INT}(2.78) = 2$. For negative numbers, however, the result is one less than one might assume: $\text{INT}(-2.78) = -3!$

As can be seen from the examples given above, the number ('X') must always be included in brackets. Usually, it is also permissible to use a variable or even an algebraic expression here. A few examples are given in the following program:

```
> 10 REM EXAMPLES OF STANDARD FUNCTIONS
> 20 PRINT "ENTER ANGLE IN DEGREES"
> 30 INPUT A
> 40 LET B = A/57.2958
> 50 REM B IS ANGLE IN RADIALS
> 60 PRINT "THE SINE OF"; A; "DEGREES IS"; SIN(B)
> 70 PRINT "INT(5.3) = "; INT(5.3)
> 80 PRINT "INT(-8.5) = "; INT(-8.5)
> 90 PRINT "INT(7) = "; INT(7)
> 100 END
> RUN
```

```
ENTER ANGLE IN DEGREES
? 30
THE SINE OF 30 DEGREES IS 0.5
INT(5.3)= 5
INT(-8.5)= -9
INT(7)= 7
BRK AT 100
>
```

BASIC (PART 3)

It shouldn't come as a surprise that there are exceptions to the rules given above. Some BASIC dialects don't use the absolute value of x in the LOG and SQR functions if a negative value is entered for x — they print an error indication.

In Tiny BASIC (and, therefore, in NIBL) these standard functions are unknown. For that matter, the INT function would be pointless, since Tiny BASIC only recognises whole numbers in the first place. NIBL does recognise certain other functions; these will be discussed in part 4.

Jump statements

In all program examples given so far, the programs were executed in a fixed (numerical) order. The statement with the lowest line number was carried out first, and so on. Where a different order is required, 'jump statements' can be used: 'GOTO', 'IF ... THEN ...' and so on.

GOTO

The GOTO statement is used when a 'jump' to a specified line number is required in the program. Since no initial check is required (to see whether certain specified conditions are met), GOTO is known as an 'unconditional statement'. An example:

```
> 5 N = 0
> 10 PRINT N
> 20 N = N + 1
> 30 GOTO 10
> 40 END

> RUN
0
1
2
3
(etc.)
```

In this program, N is first made equal to zero and this value is printed. In line 20, the value is increased by 1 ('incremented'); line 30 initiates a jump back to line 10, where the result (1) is printed; and so on. The computer will continue to run around this 'loop', printing all numbers from 0 up — until it either runs out of paper or reaches its maximum count.

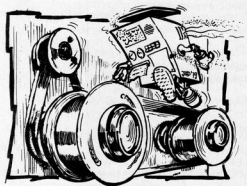

... The computer will continue to run around this loop ...

Obviously, if something like this occurs when running a program (due to a programming error), there must be some way to stop the computer. There is: the 'BREAK' key. As soon as this key is operated, the computer will stop the program and print out 'BRK AT 20' or something similar.

IF ... THEN ...

Often, a jump to a new line number is only required if certain conditions are fulfilled. The 'conditional statement' offers the possibility of executing different sections of program, depending on intermediate results. In general, the statement will be entered as

IF (relational expression) THEN (line number).

The 'relational expression' will normally be some kind of comparison, for instance ' $X = 10$ ' or ' $A > B$ '. If the result of the comparison is 'true', the computer will jump to the specified line number; if not, it will simply proceed to the next program line.

As an example, let us assume that a program is required that will print out the multiplication table of any number (' X '). The flow chart for a suitable program would be as shown in figure 1.

The sequence of operations is as follows: after the 'initialisation' procedure — in this case, making $N = 1$ — the computer will request the value of X (step 2). In steps 3 and 4, $1 \times X$ is calculated and printed, after which N is incremented by 1 (step 5). Then, in step 6, the value of N is checked: if it is smaller than or equal to 10, the computer must jump back to step 3 for the next calculation. After calculating and printing all values up to $10 \times X$, N will become 11 in step 5, the result of the comparison in step 6 will be 'false' and the program will have reached the END.

BASIC (PART 3)

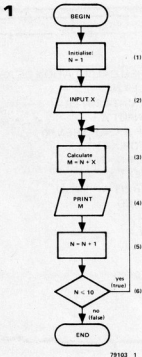

The corresponding program is as follows:

```

> 10 REM THIS PROGRAM CALCULATES
> 15 REM AND PRINTS 1xX THROUGH 10xX
> 20 LET N= 1
> 30 PRINT "ENTER X"
> 40 INPUT X
> 50 LET M = N * X
> 60 PRINT N; " * "; X; " = "; M
> 70 LET N= N+1
> 80 IF N <= 10 THEN 50
> 90 END
> RUN
ENTER X
? 12
1 * 12 = 12
2 * 12 = 24
...
(etc.)
10 * 12 = 120
BRK AT 90
>
  
```

In some BASIC dialects (including NIBL), it is possible to enter a statement after THEN, instead of a line number. In that case, if the result of the comparison is true the statement will be executed; otherwise it will be ignored.

In NIBL, if a jump to a line number is required 'GOTO' must be used instead of 'THEN'. The two possibilities are therefore as follows in NIBL:

IF (relational expression) GOTO (line number), and
IF (relational expression) THEN (statement).

FOR ... NEXT ...

Another way to run through the same section of program several times in succession is by means of the FOR ... NEXT ... statement. This really consists of two statements that must be entered on different program lines, as illustrated in the following example:

```

> 10 FOR A= 1 TO 5
> 20 PRINT A*2
> 30 NEXT A
> 40 END
> RUN
1
4
9
16
25
BRK AT 40
>
  
```

In the FOR statement, a variable (A), an initial value (1) and a final value (5) are specified. The section of program between the FOR and the NEXT statements is executed several times, starting with the initial value for A and then incrementing it by 1 until the final value is reached.

The initial and final values need not be given as numbers. Both variables and expressions can also be used (for instance: 'For A = N TO 50 * N'). The final value should, of course, be greater than (or at least equal to) the initial value.

It is not a good idea to use the 'running variable' (A in the example given above) at any other point in the program — except for other FOR statements. The statements between FOR and NEXT are often referred to as the 'FOR-NEXT block'. Before executing a FOR-NEXT block, the computer first calculates the initial and final values for the running variable. If these values depend on another variable, its value is taken at that moment; once calculated, the initial and final values remain unchanged as the block is executed, so that even if the value of the variable is then altered this will have no effect on the final value.

BASIC (PART 3)

A more 'practical' example of the FOR...NEXT... statements is a program for the calculation of $A!$. ($A! = 1 * 2 * 3 * \dots * (A-2) * (A-1) * A$. For example: $3! = 1 * 2 * 3 = 6$. By definition, $0! = 1$.) A flow chart for a suitable program is given in figure 2.

2

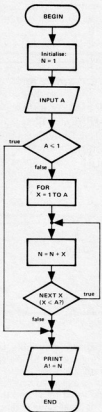

79103 2

After the initialisation procedure, the value for A is entered (a positive number). If $A = 0$ or 1 , the result will be 1 and there is no point in running through the whole program — in fact for $A = 0$ it wouldn't work, since the final value in the FOR statement would be less than the initial value — so the result can be printed immediately. For all other values of A , the calculation described above is performed in the FOR-NEXT block and the result is then printed. The corresponding program is as follows:

```

> 10 REM CALCULATION OF A!
> 20 LET N= 1
> 30 PRINT "ENTER A"
> 40 INPUT A
> 50 IF A <= 1 THEN 90
> 60 FOR X= 1 TO A
> 70 LET N = N * X
> 80 NEXT X
> 90 PRINT A; "I ="; N
> 100 END
> RUN
ENTER A
? 3
3! = 6
BRK AT 100
>
  
```

After writing a program like this, it must be checked with several values for the variables which should give known results (in this example, say, 3 and 5); special attention should be paid to values that require a different procedure (0 and 1 in this program).

FOR...TO...STEP...

In the FOR...NEXT... statements as described so far, the running variable is increased by 1 each time round the loop. This is not always desirable: an increase by a larger or smaller amount may be required. In that case the STEP statement can be added, as follows:

FOR I = -90 TO 90 STEP 15

The running variable will now be increased in steps of 15. Other steps can be specified, and even negative steps are permitted — in other words, the running variable is decreased step-by-step. For example:

FOR I = 0 TO -90 STEP -10

A certain amount of care must be taken to ensure that the running variable can reach its final value with the specified steps. It would be asking for trouble, for example, to specify:

FOR I = 0 TO 90 STEP -10

DO...UNTIL...

The DO...UNTIL... statement is only known in relatively few BASIC dialects. The reason for

BASIC (PART 3)

discussing it here is that this statement is also known in NIBL. As an example of its use, let us consider the following program section:

```
> 170 N=0
> 180 DO
> 190 N=N+1
> 200 PRINT "EXAMPLE OF A DO - UNTIL LOOP"
> 210 UNTIL N=5
> 220 ...
```

The statements between DO and UNTIL are repeated for as long as the expression after UNTIL remains 'false'. As soon as it becomes 'true' the computer moves out of the program 'loop' and proceeds with the following statement. In the example given above, the text will be printed 5 times.

Subroutines, GOSUB . . . RETURN

When writing large programs, 'subroutines' can be extremely useful. It is often the case that a certain

section of the program is required several times - for example, a complicated input/output routine or the AI calculation described earlier. This program section is then entered after the main program, as a so-called subroutine. When it is required in the course of the main program a GOSUB statement is used, followed by the first line number of the subroutine. The subroutine itself will normally be concluded with a RETURN instruction, causing the computer to jump back to the line number immediately following the GOSUB statement in the main program.

As an example, let us assume that the computer is being used as an aid to circuit design, and that we will regularly be using two resistors in parallel to approximate a desired resistance value. A section of the main program and the subroutine might then be as follows:

```
> 110 PRINT "SELECT TWO RESISTANCE VALUES FOR R21"
> 120 GOSUB 500
> 130 A= P
> ...
> 500 REM SUBROUTINE FOR CALCULATING PARALLEL RESISTANCE"
> 510 PRINT "ENTER VALUE FIRST RESISTOR"
> 520 INPUT X
> 530 PRINT "ENTER VALUE SECOND RESISTOR"
> 540 INPUT Y
> 550 P= X*Y/(X+Y)
> 560 PRINT "THE PARALLEL RESISTANCE IS"; P
> 570 PRINT "IS THIS VALUE SATISFACTORY?";
> 580 PRINT "IF SO, ENTER 1; IF NOT, ENTER 0"
> 590 INPUT Z
> 600 IF Z=0 THEN 510
> 610 RETURN
```

BASIC (PART 3)

When the computer reaches the point in the main program where it needs the value for R21 — which will be approximated by connecting two resistors in parallel — it prints out the corresponding request and then jumps to the subroutine. Once there, the request is made more specific by asking for the value of the first resistor. Having then requested and received the second value, the parallel resistance is calculated and printed. This is followed by the query whether or not the value proves satisfactory. Depending on the answer, the computer will either repeat the subroutine (asking for new values) or else jump back to the main program and assign the calculated value to the corresponding variable (A) in the main program.

3

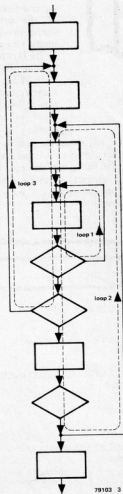

Program loops

Several statements have now been discussed that can be used when program loops are required.

Loops within loops are also possible — in fact the program given above is an example: the subroutine, effectively, is a loop; within the subroutine, an IF . . . THEN . . . statement is used to create a further loop.

Figure 3 illustrates 'loops within loops' in a flow chart. In this case, however, loop 3 is 'dangerous'. If loop 2 is either a FOR-NEXT or a DO-UNTIL loop, a jump to a line number outside this loop is not permitted: the computer must first be given the chance to complete its countdown (final value in the FOR-NEXT statement) or fulfil the condition specified (in the DO-UNTIL statement). Furthermore, a program should not loop-the-loop ad infinitum. Each loop within another loop is referred to as 'one (further) level down' and when 'nesting' loops in this way there is a maximum number of levels (depending on the BASIC dialect) that should not be exceeded. In NIBL, for instance, the maximum nesting depths for the various types of loop are as follows:

| | |
|--------------|----------|
| GOSUB-RETURN | 8 levels |
| FOR-NEXT | 4 levels |
| DO-UNTIL | 8 levels |

If the computer detects loop programming errors, it will indicate this by printing out some suitable comment. In NIBL, for instance, the indications are as follows:

| Print-out | Meaning |
|------------|---|
| NEST ERROR | there are too many loops within loops |
| FOR ERROR | FOR is not followed by NEXT |
| NEXT ERROR | NEXT was not preceded by FOR |
| NOGO ERROR | the line number indicated in a GOTO or GOSUB statement does not exist |
| RTRN ERROR | RETURN was not preceded by GOSUB |
| UNTL ERROR | UNTIL was not preceded by DO |

A program example: Pay as you earn

To illustrate the possibilities of the BASIC theory discussed so far, let us consider a program that can calculate the costs involved in hire-purchase or pay-as-you-earn. In this case we will assume that:

- A fixed sum is repayed each month, which includes interest: the monthly payment M. This sum is to be calculated.
- The cost price of the item that we wish to buy is C.
- A starting capital, S, is available.
- A loan, L, is therefore required: $L = C - S$.
- The interest rate is P (%).
- The loan is to be repayed within N years.

BASIC (PART 3)

In the course of the program, we will also calculate:

- The amount already repayed (R) after X years.
- The amount still to be repayed (O, for Outstanding) after X years.
- The total interest, I, payed in N years.
- How many times the cost of the item has been payed after N years (F).

To sum it up, the following inputs are required:
the cost price, C;
the starting capital, S;
the interest rate, P;
the total number of years, N;
if required, an intermediate number of years, X.
Based on this data, the following will be calculated:

- The loan,
 $L = C - S$;
- The monthly payment,

$$M = \frac{1}{12} \cdot L \cdot \frac{P}{100} \cdot \frac{(1 + \frac{P}{100})^N}{(1 + \frac{P}{100})^N - 1}$$

- The amount repayed after X years:

$$R = L \cdot \frac{(1 + \frac{P}{100})^X - 1}{(1 + \frac{P}{100})^N - 1}$$

- The amount outstanding after X years,
 $O = L - R$;
- The total interest payed in N years,
 $I = M \cdot 12 \cdot N - L$;
- How many times the cost has been payed,
 $F = \frac{I + L}{L}$.

In these calculations, $(1 + \frac{P}{100})^N$ appears several times. It is a good idea to calculate it at the beginning of the program and assign the value found to a further variable, V. The various formulae will then appear in BASIC as follows:

```
L = C - S
V = (1 + P/100)↑N
M = L * (P / 1200) * V / (V - 1)
R = L * ((1 + P/100)↑X - 1) / (V - 1)
O = L - R
I = M * 12 * N - L
F = (I + L)/L
```

Which brings us to the flow chart and program:

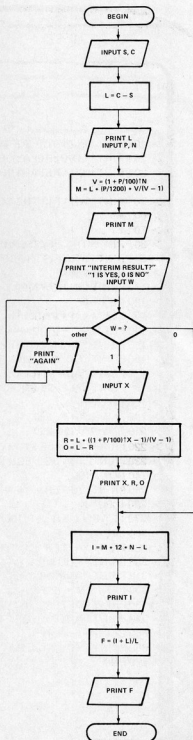

79103

BASIC (PART 3)

```
> 10 PRINT "ELEKTOR SOFTWARE SERVICE"
> 20 PRINT "LOAN REPAYMENT"
> 30 PRINT "WHAT STARTING CAPITAL IS AVAILABLE?"
> 40 INPUT S
> 50 PRINT "WHAT IS THE COST PRICE?"
> 60 INPUT C
> 70 LET L = C - S
> 80 PRINT "THE NECESSARY LOAN IS"; L; "POUNDS"
> 90 PRINT "WHAT IS THE INTEREST RATE?"
> 100 INPUT P
> 110 PRINT "IN HOW MANY YEARS MUST THE LOAN BE REPAYED?"
> 120 INPUT N
> 130 LET V = (1 + P/100) ↑N
> 140 LET M = L * (P/1200) * V / (V - 1)
> 150 PRINT "THE MONTHLY PAYMENT IS"; M; "POUNDS"
> 160 PRINT "DO YOU WISH TO KNOW THE AMOUNTS ALREADY REPAYED?"
> 170 PRINT "AND STILL OUTSTANDING AFTER A NUMBER OF YEARS?"
> 180 PRINT "PLEASE ENTER 1 FOR YES, OR 0 FOR NO"
> 190 INPUT W
> 200 IF W=0 THEN 320
> 210 IF W=1 THEN 250
> 220 PRINT "PLEASE STUDY THE KEYBOARD CAREFULLY, THEN"
> 230 PRINT "ENTER 1 FOR YES, OR 0 FOR NO. TRY AGAIN"
> 240 GOTO 190
> 250 PRINT "AFTER HOW MANY YEARS?"
> 260 INPUT X
> 270 LET R = L * ((1 + P/100)↑X - 1) / (V - 1)
> 280 LET O = L - R
> 290 PRINT "AFTER"; X; "YEARS"
> 300 PRINT "YOU WILL HAVE REPAYED"; R; "POUNDS"
> 310 PRINT "AND"; O; "POUNDS WILL REMAIN OUTSTANDING"
> 320 LET I = M * 12 * N - L
> 330 PRINT "AFTER"; N; "YEARS, YOU WILL HAVE PAYED"
> 340 PRINT "A TOTAL OF"; I; "POUNDS INTEREST"
> 350 LET F = (I + L)/L
> 360 PRINT "YOU WILL HAVE PAYED"; F; "TIMES THE ORIGINAL LOAN"
> 370 END
```

BASIC (PART 3)

Lines 220, 230 and 240 are included in the program in case an 'impossible' answer is given ('5', for instance) instead of 0 or 1. Since neither of the conditions given in lines 200 and 210 are then

fulfilled, the computer will warn the operator and jump back to line 190 for another try. Having entered the program, it can be tried out:

```
> RUN
ELEKTOR SOFTWARE SERVICE
LOAN REPAYMENT
WHAT STARTING CAPITAL IS AVAILABLE?
? 0
WHAT IS THE COST PRICE?
? 10000
THE NECESSARY LOAN IS 10000 POUNDS
WHAT IS THE INTEREST RATE?
? 9
IN HOW MANY YEARS MUST THE LOAN BE REPAYED?
? 30
THE MONTHLY PAYMENT IS 81 POUNDS
DO YOU WISH TO KNOW THE AMOUNTS ALREADY REPAYED
AND STILL OUTSTANDING AFTER A NUMBER OF YEARS?
PLEASE ENTER 1 FOR YES, OR 0 FOR NO
? 2
PLEASE STUDY THE KEYBOARD CAREFULLY, THEN
ENTER 1 FOR YES, OR 0 FOR NO. TRY AGAIN
? 1
AFTER HOW MANY YEARS?
? 10
AFTER 10 YEARS
YOU WILL HAVE REPAYED 1114 POUNDS
AND 8886 POUNDS WILL REMAIN OUTSTANDING
AFTER 30 YEARS, YOU WILL HAVE PAYED
A TOTAL OF 19160 POUNDS INTEREST
YOU WILL HAVE PAYED 2.916 TIMES THE ORIGINAL LOAN
```

BASIC (PART 3)

QUESTIONS

1. Is it permissible to enter more information in a 'data block' than is actually required in the program? And what about storing less data than required?
2. What use is the REM statement?
3. Can extensive use of the REM statement cause problems?
4. What effect will 'jump' statements have on the time it takes the computer to run the program (the 'execution time')?
5. When using the FOR ... TO ... STEP ... statement, should the final value always be larger than the initial value?
6. What is the advantage of using subroutines?
7. When using FOR-NEXT and DO-UNTIL loops, why is it not permitted to 'jump out of the loop'?

ANSWERS TO QUESTIONS IN PART 2.

1. If an interpreter program were stored in RAM, it would be lost when the computer is switched off. It would then have to be re-entered before running even the shortest of programs. For this reason, it is normally stored in ROM.
2. The effect of the SCRATCH command is to erase the current program and the display.
3. The CLEAR command is used to reset the variables to 0. This command is often given before the RUN command; in fact, in some BASIC dialects it is effectively included in the RUN command.
4. The errors in the program lines are as follows:
 - a) 150 LI ST 5: a space in the 'key word' (LIST) is forbidden.
 - b) 1 0 PRINT 18: a space within the line number is forbidden.
 - c) 160 PRINT CHAIR: quotation marks should be included ("CHAIR").
 - d) 170 PRINT 1253 14: a space within a number is not permitted.
 - e) 190 LET A = 0.31: in most BASIC dialects that recognise decimal fractions, '.31' should be written instead of '0.31'.
 - f) 200 PRINT 4.35E1.2: the number following the E must be a whole number — the decimal point is never permitted here.
5. a) $3^2 + 8 + 15/3 = 19$.
b) $17 - 24/3/2 = 13$.
6. In BASIC, a variable should consist of one letter followed by not more than one digit, so 'A15' is not permitted.

Summary of statements and commands used in part 3.

| | |
|--|--|
| INPUT <i>variable(s)</i> | This statement causes the computer to request keyboard entry of value(s) that must be assigned to the specified <i>variable(s)</i> . |
| READ <i>variable(s)</i> READ <i>variable(s)</i> . . | The <i>variable(s)</i> listed after the READ statement(s) are assigned the value(s) |
| DATA <i>data, data...</i> | given after the DATA statement. |
| RESTORE | This statement causes the data block to be re-used from the beginning. |
| REM <i>text</i> | The specified <i>text</i> appears in a listing, but has no effect on the program. |
| GOTO <i>line number</i> | This causes a jump to the specified <i>line number</i> . |
| BREAK | A key on the terminal that is used to stop the program. |
| IF <i>comp.</i> ... THEN <i>line number</i> ... THEN <i>statement</i> ... GOTO <i>line number</i> | If the result of the <i>comparison</i> after IF is true, the computer 'jumps' to the specified <i>line number</i> ; otherwise the program is continued on the next line. In NIBL, a <i>statement</i> can be given instead of a <i>line number</i> ; if a jump to a <i>line number</i> is required 'GOTO' must be used instead of 'THEN'. |
| FOR ... TO ... STEP . NEXT ... | A 'running variable' is assigned an 'initial value', both as specified after FOR (e.g. FOR A=1). The statements between FOR and NEXT (the 'FOR-NEXT block') are then carried out; the running variable is increased by the specified step (e.g. STEP 1/5), after which the FOR-NEXT block is repeated; and so on until the 'final value' specified after TO (e.g. TO 90) is reached or exceeded. If no STEP is specified, the step is automatically taken as +1. |
| DO . UNTIL <i>comp.</i> | This 'loop' is known in NIBL. The statements between DO and UNTIL are repeated until the <i>comparison</i> specified after UNTIL becomes 'true'. |
| GOSUB <i>line number</i> | This causes a jump to the subroutine that starts at the specified <i>line number</i> . |
| RETURN | Last statement in a subroutine: it causes a jump back to the main program. |

A very large low-frequency range is not necessarily a good thing. Often when a record is played at a reasonable volume the woofers occasionally 'strike' far further than the normal (acceptable) distance. This is usually due to undesirable distortion in the range of about 1 to 10 Hz. This phenomenon is limited only to record players; it is not noticed with compact disc players, radio tuners or tape players. The reason is that these last three have a high-pass filter of about 20 Hz fitted somewhere in the electronics or in the signal source. As far as this circuit is concerned, therefore, we are only interested in the record player.

For most people a record player is still the best source of high-quality sound reproduction. (The CD — compact disc — system may be technically better but is far less popular.) A lot of attention is paid to the MM (moving magnet) and MC (moving coil) inputs in 'reasonable-quality' amplifiers as the best results are possible by making use of these inputs. A good amplifier must nowadays have a frequency range right down to (practically) d.c. values — the merit of which we will not discuss — but when combined with a turntable this can make life difficult for loudspeakers. In order to remove the problem, however, we must first of all know how it arises.

Resonance and warped records

Most subsonic problems are caused by



rumble detector

Manufacturers of audio equipment are constantly competing against each other by improving the quality of their products. As a result even inexpensive amplifiers now have an extremely good frequency range, especially at low frequency. A lower cut-off point of a few hertz is certainly no exception and some actually go right down to d.c. This is all to the good as far as the quality of sound reproduction is concerned but it is also disadvantageous to a certain extent. Subsonic noise can be passed on to the loudspeakers and could even damage them. Murphy's Law of Acoustics comes into play here, of course: as this noise is subsonic it cannot be heard so how do you know that it is there? That can be very difficult ... unless you build this rumble detector, which indicates, by means of a LED, when the subsonic part of an output signal becomes too great.

resonance in the turntable and pick-up arm. It all starts at the point where the arm pivots, its fulcrum in other words. The arm always pivots on some sort of elastic structure to allow the needle to move freely in the record grooves. Because there is a reaction between the mass of the arm and the elasticity of the mounting the assembly will have a resonant point. The frequency at which resonance occurs depends on the mass of the arm and the type of material on which it pivots. The

extent of the resonance depends mainly on the inherent damping of the fulcrum and any damping intentionally built in. When choosing a cartridge to fit to an arm, or *vice versa*, care must be taken to be sure that the resonant frequency of the combination is not in the audible range. By the same token the resonant point must not be so low that it is triggered by warps in the record or by a vibrating floor. A resonant frequency of about 10 Hz is generally considered to be optimal, although

traces ultra-low frequency signals

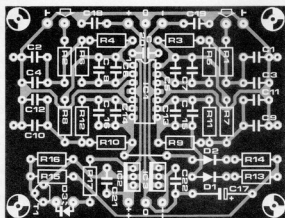
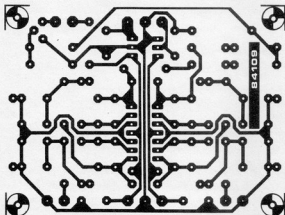

off characteristics must be very steep to prevent the circuit from reacting to bass frequencies that are acceptable for the loudspeakers. This is the reason for using 24 dB/octave fourth-order Butterworth filters. (For detailed information about this and other types of filters refer to the article 'active crossover filter' published in the October 1984 issue of *Elektron*.) The actual multiple-feedback arrangement used for the filters makes them very stable and that is more than enough justification for their relative complexity. Each filter consists of two 12 dB/octave sections — A1/A3 and A2/A4. The component values chosen set the cut-off frequency to about 10 Hz so signals up to about 12 Hz can be detected. The output signals from the filters are half-wave rectified and then added together. The resultant signal charges capacitor C17 quickly. When the voltage on this capacitor reaches about 2.5 V transistor T1 conducts and causes the LED to light. After the subsonic signal has passed the LED remains lit for a certain time, dependent upon the d.c. voltage across C17.

Power for the circuit is provided via two voltage regulators, IC2 and IC3. The maximum input voltage to this power supply section is 30 V. This can be supplied by a small transformer (2 x 15 V/50 mA, for example) in combination with a bridge rectifier and two electrolytic capacitors (such as 470 μ /25 V). If the amplifier has a suitable symmetrical 15 V from which a tap-off can be taken the components marked with an asterisk in the parts list can be left out. The current consumption is a mere 20 mA so this will not prove an excessive burden to an amplifier. The last thing to be done is to connect the circuit in parallel with the amplifier's loudspeaker outputs and the detector is ready for use.

rumble detector

Parts list

Resistors:

R1...R6 = 47 k
 R7...R12 = 100 k
 R13, R14 = 100 Ω
 R15 = 33 k
 R16 = 10 k
 R17 = 1 k

Capacitors:

C1, C2, C21*,
 C22* = 330 n
 C3, C4 = 220 n
 C5, C6 = 180 n
 C7, C8 = 27 n
 C9, C10 = 470 n
 C11, C12 = 150 n
 C13, C14 = 39 n
 C15, C16 = 1n8
 C17 = 47 μ /16 V
 C18...C20 = 100 n

Semiconductors:

D1, D2 = 1N4148
 D3 = LED, red
 T1 = BC549C
 IC1 = TL084
 IC2* = 7815
 IC3* = 7915

* = not needed if a symmetrical 15 V supply is used

Figure 2. Voltage regulators are among the components found on the printed circuit board. If a + and -15 V supply can be tapped off the amplifier these two stabilisers are not needed.

Filter component values:

Butterworth 4th order
 (24dB/octave)

C5 + C7 = C6 + C8 =
 1.85/6 π fR

C1 + C3 = C2 + C4 =
 3/3.7 π fR *

where R = R1 = R2 =
 R3 = R4 = R5 = R6

C13 + C15 = C14 +
 C16 = 0.77/6 π fR

C9 + C11 = C10 + C12 =
 3/1.54 π fR

where R = R7 = R8 =
 R9 = R10 = R11 = R12

(All values are given in Ω ,
 Hz and fR)

EVENT COUNT ?

B-INPUT ?

E-INPUT ?

PERIODTIME ?

FREQUENCY ?

PULSE TIME ?

POS SLOPE ?

PER 0000000 SEC



microprocessor-controlled frequency counter

accurate, fast,
user-friendly and
practical

Superlatives simply have to be used when describing this frequency counter, but we will try not to let it get out of hand. We think it is only natural to feel a certain amount of pride, however. Here, at last, is a do-it-yourself frequency meter whose capabilities, features and ease of use are comparable to much more expensive ready-made (professional) equipment. This is a tribute to the Elektor designers who continually burned the midnight oil working on the design. Their advice to anybody who is thinking of building or buying a new frequency counter is to read this article and study the circuit diagram first. The chances are that this will be your next frequency meter.

Technical specifications:

- Frequency range: 0.01 Hz...1.2 GHz
- Period time measurement: 10 ns...100 s
- Pulse time measurement: 0.1 μs...100 s
- Event counter: 0...10⁹ pulses
- User-selectable accuracy to 6 or 7 digits
- Measuring time for frequency measurements: <0.2 s (6 digits) at f > 20 Hz <2 s (7 digits) at f > 2.5 Hz
- Auto-ranging in all ranges
- 16-digit alphanumeric display with interactive operation
- Sensitivity:
 - input A: 10 mV_{rms} (2 MΩ)
 - input B: TTL, CMOS level (R_i 25 kΩ)
 - input C: 10 mV_{rms} (50 Ω)
- with prescaler (>100 MHz): 100 mV_{rms} (50 Ω)

Many of our readers regard microprocessors as a scourge and something that has no place in a respectable 'electronic' circuit. Even having read the title on this page we hope that you have none the less read this far because we are now going to entreat you to bear with us and read the remainder of this article. This frequency counter does contain a microprocessor but for all intents and purposes it can be considered as just another 'black box'. Its use does, however, allow the design to be made more versatile and totally removes the need for a user's manual. Surely this is enough reason to turn a blind eye to the fact that this test instrument is 'cursed' with a microprocessor.

Let us look at the frequency counter's features one by one, starting with the auto-ranging possibility. In most meters this would have required a handful of components but in this design the 'calculator' does all the work.

The second point is the measuring method used, which was mentioned in the introductory article published in last month's issue. This so-called reciprocal measuring is only possible with the aid of a microprocessor as there are a lot of calculations to be made. The advantages of this method are maximum accuracy with a very short measuring time. It is

used both for frequency and period measurements. A secondary benefit is that multi-position rotary switches are unnecessary as simple push buttons are sufficient.

If the circuit has a microprocessor anyway why not use an alphanumeric display? This, again, is easier to use. The frequency meter plays a game of question and answer with the user, who then makes a choice of the function desired by pressing a YES or a NO button. The display always shows what is being measured and what the units are: such as 'FREQ. 1.234567 KHZ' or 'PER. 8.61059 MSEC'. The price of the alphanumeric display and the associated controller IC is comparable to that of a set of good 7-segment displays plus drivers so cost does not enter into the equation. Extensions and modifications can easily be included in this frequency counter; usually this is a matter of changing part of the software. This line of thought could lead to such things as an IEEE output or feeding in offset frequencies. Finally, we draw your attention to the front panel foil with built-in low-pressure membrane switches. This gives the project a very professional appearance and simplifies fitting it into the case.

The measuring principle

If the frequency counter electronics are considered in the form of blocks a first rough sub-division leaves us with the three parts shown in figure 1: the microprocessor, the counter hardware and the display controller. The microprocessor section consists of a standard 6502 system with RAM (6116), EPROM (2732) and PIA (6821). The microprocessor works with the program stored in the EPROM and uses the RAM memory as a notepad and to store data. Communication with the other hardware is via the PIA (peripheral interface adapter). The display controller will be described in next month's issue so we will not deal with it now. The counter section makes up most of the circuit so we will look at that in detail, using block diagrams and timing charts, to give a better understanding of the operation of the whole circuit.

All the hardware is controlled by the microprocessor, with the aid of a pair of multiplexers to select the various measuring procedures. Each of the possibilities will be discussed in detail on the basis of a timing chart and a block diagram containing only the components appropriate to a particular function. The multiplexers are considered as straight-through links. First, however, we must see how all the measurements are made.

A lot of calculation

The article in the last month's issue (called 'part 0' because it was only an introduction, intended to whet your appetite) skimmed over the frequency counter's *modus operandi*. The microprocessor starts by setting the programmable divider to its lowest value. This means that the divider stops the measurement after a single period of the input signal. This is a test to prepare for the actual measurement so that the right division factor can be selected. The period time is worked out from the test and the processor then calculates which multiple of this period

can be stored in the counter within the desired measuring time. Based on this the programmable divider factor, which is always a power of 2, is set. The measuring time is then defined by: $2^n \times T$, where T is the period time measured and n is the number selected for the divider. The number of period times that are counted is always a power of 2 so the measuring time for different frequencies can also vary by a factor of 2. As an example, assume an accuracy of 6 figures is selected. The gate time (measuring time) for this accuracy is at least 0.1 s. If the frequency to be measured is 5 kHz its period time will be $T = 200 \mu\text{s}$. After the test measurement the microprocessor quickly makes the following calculations: $2^n \times 200 \times 10^{-6} \geq 0.1$, so $2^n \geq 500$, giving $n = 9$ and $2^9 = 512$.

The last number is the factor for the programmable divider. The gate time is then: $512 \times 200 \times 10^{-6} = 0.1024 \text{ s}$.

If the frequency were 2.6 kHz the period would be: $T = 385 \mu\text{s}$.

$2^n \times 385 \times 10^{-6} \geq 0.1$, whereby $2^n \geq 260$, which gives $n = 8$ and $2^8 = 256$.

The same division factor is selected but the gate time is now:

$512 \times 385 \times 10^{-6} = 0.197 \text{ s}$.

At 2.5 kHz the gate time does become less as the division factor is then $2^8 = 256$. The measuring time is given by:

$2^8 \times 400 \times 10^{-6} = 0.1024 \text{ s}$.

When the 'real' measurement has been made the contents of the counter (X) is read out by the processor. The result is the gate time multiplied by 10^7 (the reference frequency of 10 MHz). The gate time is $2^n \times T$, so $X = 10^7 \times 2^n \times T$. Taking the example of $f = 2.6 \text{ kHz}$ again we see that $T = 1/2600 \text{ s}$. This gives $X = 10^7 \times 512 \times 1/2600 = 1969230$. Based on this figure and the division factor selected the microprocessor can calculate the frequency or period time, whichever the user has chosen.

$f = (10^7 \times 2^n)/X = 2.60000 \text{ kHz}$

1

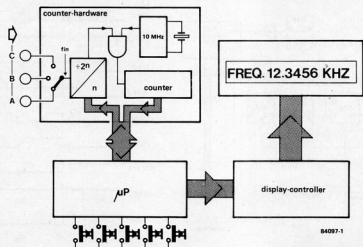

Figure 1. The block diagram for the frequency counter in vastly simplified form. The microprocessor controls virtually all the rest of the electronics.

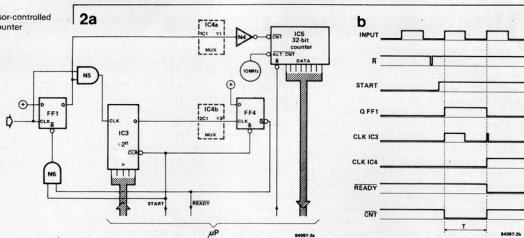

Figure 2. These are the components that play a part in test measurements for the frequency or period functions. The timing chart shows what happens to the relevant signals.

$T = X / (10^7 \times 2^2) = 384.615 \mu\text{s}$
That, basically is how the frequency and period time are calculated. We will now look at the electronics needed to achieve this.

Frequency and period measurements

The set-up used for the frequency and period 'test' measurements is shown in figure 2a. The output signal of FF1 is fed to N4 and the Q output of IC3 is connected to FF4's clock input (via a multiplexer in each case). The sequence of events is shown in the timing chart (figure 2a). First the 32-bit counter is reset and the hardware is enabled by means of the START signal. The lowest possible division factor, 2^0 , is selected for IC3. The next rising edge of the input signal makes FF1's Q output high so N5 can then pass the input signal on to IC3. At the same time the CNT input of ICS goes low so it starts counting 10 MHz pulses. The second rising edge of the input signal causes the Q output of IC3 to go high. (This output becomes '1' after the 2^{n-1} th rising edge if a division factor of 2^n is selected.) The

READY line then becomes zero and resets FF1. This flip-flop's Q output then goes low with the result that ICS stops counting. Even though IC3's division factor was set to 4 the output becomes high after a single input-signal period. The contents of ICS is the result of counting 10 MHz pulses for one period and this figure is used to decide what division factor has to be set for the actual measurement. For the actual measurement FF3's Q output is connected to N4 and the Q output to FF4's clock input (see figure 3a). The microprocessor then sets IC3 to the division factor that it has selected. The first rising edge after the START signal takes FF1's Q output high so N5 can then pass the input signal on to IC3. After 2^{n-1} rising edges the output of IC3 becomes '1'; this signal clocks FF3 and only then can ICS start counting 10 MHz pulses. The next clock pulse for FF3 comes after exactly 2^n periods and FF3 then flips and stops counter IC3. At the same moment the READY line is taken low by FF4 to inform the processor that the measurement is completed. The counter's contents and IC3's division factor are then used to calculate the frequency or period. When

Figure 3. This arrangement is used for actual frequency or period measurements.

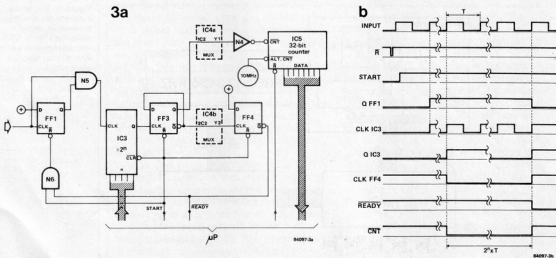

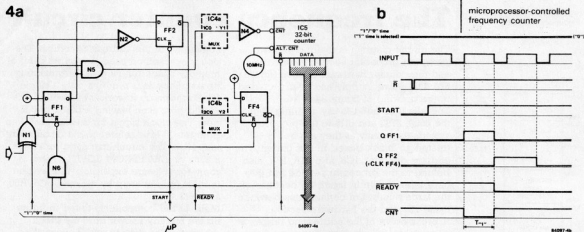

this is done the result is passed to the display and the circuit is then ready to start the next measurement.

Pulse time

Pulse time is measured on the basis of the circuit seen in figure 4. The signal is input via an EXOR gate (N1) to enable the microprocessor to define whether the '1' or the '0' time is measured. The timing chart of figure 4b assumes that N1 does not invert the signal so the '1' time is measured. Once the hardware is STARTed the Q output of FF1 goes high with the input signal's first rising edge. The 32-bit counter is triggered via N5 and stops again at the input's falling edge. At the falling edge a clock pulse is fed to FF4 via FF2 and N2. The READY line (which goes low) then informs the processor that the measurement is complete and FF1 is also prevented from reacting to any more input signals. The contents of the counter is then equal to the pulse time in tenths of microseconds (as 10 MHz pulses were counted). This makes further calculations unnecessary.

The width of the pulses that are counted ($1/10^7 = 0.1 \mu\text{s}$) means that the resolution

for pulse-time measurements is also $0.1 \mu\text{s}$ and the result displayed takes this into account. A number shown in microseconds on the display will never have more than one figure after the decimal point. The shorter the time measured the fewer figures will appear on the display.

Counting pulses

This is the easiest function so its block diagram (figure 5a) is also the most straightforward. Again N1 enables the microprocessor to choose whether the counter reacts to a rising or falling edge at the input. The input signal is then used to clock counter IC5 directly (so the 10 MHz reference frequency is no longer connected to the counter's ALT.CNT input). The microprocessor regularly examines the contents of the counter and outputs the result to the display.

The actual components used for each of the frequency counter's functions were given in each of the block diagrams so they can be more or less ignored in the actual circuit diagram. This is a distinct advantage as the circuit's complexity makes it difficult to see directly which parts relate to which function.

Figure 4. Pulse times are measured using the layout seen here and the appropriate signal changes are indicated.

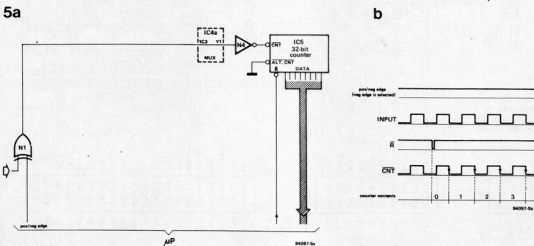

Figure 5. Very few components are needed for the event counter function, which uses this set-up.

The frequency counter circuit

Memory map

| | |
|-------|------------------------------------|
| 0FFFF | EPROM (2732) |
| 0C000 | NOT USED |
| 0D000 | STPLED (= strobeLED DS) |
| 0A000 | CNTR5 (= counter reset LS7000) |
| 09FFF | |
| 08000 | SCRL (= scan counter reset LS7000) |
| 07FFF | |
| 05000 | CNTR (LS7000) |
| 04FFF | |
| 03000 | PIA (8921) |
| 01FFF | |
| 00000 | RAM (6116) |

Figure 6a. The processor section of the circuit comprises the microprocessor itself and two memory chips, a ROM (EPROM, actually) and a RAM. The power supply is also shown in this diagram.

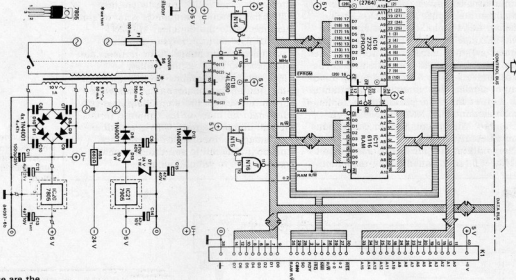

Table 1. These are the connection details for the three connectors in the frequency meter circuit.

| K3 | | K2 | | K1 | |
|----------------|-------|-----|--------|------|---------|
| C/H | 01 20 | 01H | 01 20 | NC | 01 20 |
| B | 03 40 | NC | 03 40 | IN0 | 03 40 |
| C/S2 | 05 60 | NC | 05 60 | D2 | 05 60 |
| -5V | 07 80 | NC | 07 80 | D1 | 07 80 |
| U ₊ | | 01A | 01 10A | D4 | 09 10A |
| | | 01B | 01 10B | D5 | 09 10B |
| | | 01C | 01 10C | D6 | 09 10C |
| | | 01D | 01 10D | D7 | 09 10D |
| | | 01E | 01 10E | D8 | 09 110A |
| | | 01F | 01 10F | D9 | 09 110B |
| | | 01G | 01 10G | D10 | 09 110C |
| | | 01H | 01 10H | D11 | 09 110D |
| | | 01I | 01 10I | D12 | 09 110E |
| | | 01J | 01 10J | D13 | 09 110F |
| | | 01K | 01 10K | D14 | 09 110G |
| | | 01L | 01 10L | D15 | 09 110H |
| | | 01M | 01 10M | D16 | 09 110I |
| | | 01N | 01 10N | D17 | 09 110J |
| | | 01O | 01 10O | D18 | 09 110K |
| | | 01P | 01 10P | D19 | 09 110L |
| | | 01Q | 01 10Q | D20 | 09 110M |
| | | 01R | 01 10R | D21 | 09 110N |
| | | 01S | 01 10S | D22 | 09 110O |
| | | 01T | 01 10T | D23 | 09 110P |
| | | 01U | 01 10U | D24 | 09 110Q |
| | | 01V | 01 10V | D25 | 09 110R |
| | | 01W | 01 10W | D26 | 09 110S |
| | | 01X | 01 10X | D27 | 09 110T |
| | | 01Y | 01 10Y | D28 | 09 110U |
| | | 01Z | 01 10Z | D29 | 09 110V |
| | | | | D30 | 09 110W |
| | | | | D31 | 09 110X |
| | | | | D32 | 09 110Y |
| | | | | D33 | 09 110Z |
| | | | | D34 | 09 110A |
| | | | | D35 | 09 110B |
| | | | | D36 | 09 110C |
| | | | | D37 | 09 110D |
| | | | | D38 | 09 110E |
| | | | | D39 | 09 110F |
| | | | | D40 | 09 110G |
| | | | | D41 | 09 110H |
| | | | | D42 | 09 110I |
| | | | | D43 | 09 110J |
| | | | | D44 | 09 110K |
| | | | | D45 | 09 110L |
| | | | | D46 | 09 110M |
| | | | | D47 | 09 110N |
| | | | | D48 | 09 110O |
| | | | | D49 | 09 110P |
| | | | | D50 | 09 110Q |
| | | | | D51 | 09 110R |
| | | | | D52 | 09 110S |
| | | | | D53 | 09 110T |
| | | | | D54 | 09 110U |
| | | | | D55 | 09 110V |
| | | | | D56 | 09 110W |
| | | | | D57 | 09 110X |
| | | | | D58 | 09 110Y |
| | | | | D59 | 09 110Z |
| | | | | D60 | 09 110A |
| | | | | D61 | 09 110B |
| | | | | D62 | 09 110C |
| | | | | D63 | 09 110D |
| | | | | D64 | 09 110E |
| | | | | D65 | 09 110F |
| | | | | D66 | 09 110G |
| | | | | D67 | 09 110H |
| | | | | D68 | 09 110I |
| | | | | D69 | 09 110J |
| | | | | D70 | 09 110K |
| | | | | D71 | 09 110L |
| | | | | D72 | 09 110M |
| | | | | D73 | 09 110N |
| | | | | D74 | 09 110O |
| | | | | D75 | 09 110P |
| | | | | D76 | 09 110Q |
| | | | | D77 | 09 110R |
| | | | | D78 | 09 110S |
| | | | | D79 | 09 110T |
| | | | | D80 | 09 110U |
| | | | | D81 | 09 110V |
| | | | | D82 | 09 110W |
| | | | | D83 | 09 110X |
| | | | | D84 | 09 110Y |
| | | | | D85 | 09 110Z |
| | | | | D86 | 09 110A |
| | | | | D87 | 09 110B |
| | | | | D88 | 09 110C |
| | | | | D89 | 09 110D |
| | | | | D90 | 09 110E |
| | | | | D91 | 09 110F |
| | | | | D92 | 09 110G |
| | | | | D93 | 09 110H |
| | | | | D94 | 09 110I |
| | | | | D95 | 09 110J |
| | | | | D96 | 09 110K |
| | | | | D97 | 09 110L |
| | | | | D98 | 09 110M |
| | | | | D99 | 09 110N |
| | | | | D100 | 09 110O |

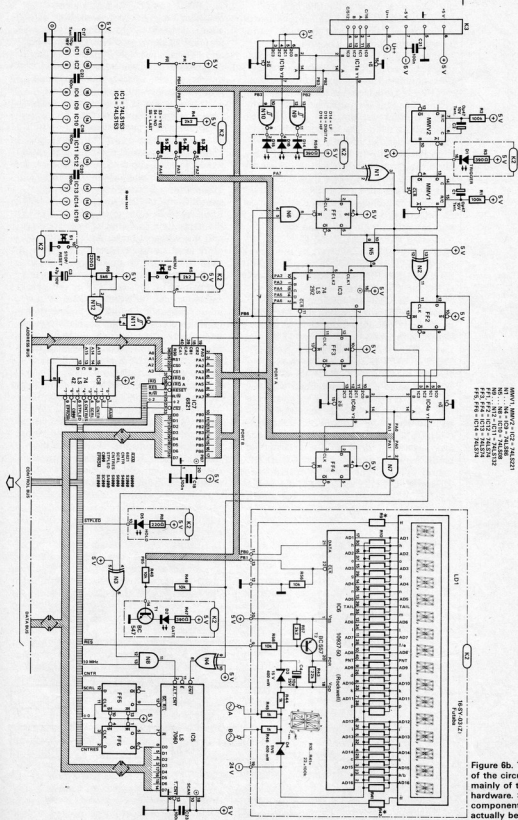

Figure 6b. The remainder of the circuit consists mainly of the counter hardware. Some of the components do not actually belong here: IC7 and IC8 are part of the processor section and the display with its controller is really a separate subsection all of its own.

signal is passed via FF6 to IC5's R input. The LS7060 IC also has two clock inputs, COUNT and ALT COUNT. One of these is used as the clock input while the other serves as the enable input. We will not deal with the remaining pins of IC7 here as the TEST COUNT, SCAN and CASCADE ENABLE are not used in our frequency counter circuit.

The gate LED D2, indicates the time during which a measurement is made, and will light if there is a '1' on line PB5 or on output Y1 of IC4. We have already seen from the block diagrams that the Y1 output defines the 32-bit counter's measuring time for frequency and period measurements. When the event counter mode is selected the input is connected to Y1 and IC5 counts the incoming pulses. The circuit is then measuring continuously, even if a lot of the time is spent waiting for a pulse, so the gate LED should light continually. For this reason the processor places a '1' on the PB5 line. For pulse width measurements either the '1' or the '0' part of the signal is measured. A long pulse time (0.5 s, for example) can easily be seen on the LED but this is not so if the measured time is short (a repetition frequency of 1 kHz and a pulse time of 200 μ s, for instance). A delay built into the software takes care of the problem. After taking a measurement the processor waits for about 200 ms before starting to measure again. The LED is driven by PB5 for a few milliseconds so that it flashes visibly. The software delay also works on the display, and in this way the last digit does not keep changing from one value to another (if, for instance, the pulse time is between 200.0 μ s and 200.1 μ s).

The gate LED makes one short and one long flash during frequency and period measurements of signals below about 100...200 Hz. The short flash is the test, while the actual measurement is made during the long flash. The LED only flashes once when very low frequency signals are being measured as the maximum measuring time is then shorter than the signal's period. In this case the 'test' is the actual measurement.

Finally there is STPLED D5, which indicates that the display is frozen and that no more measurements are being carried out. This LED is linked to output '5' of the address decoder and lights if the relevant memory block is addressed. The processor must then run through a loop in which the LED is constantly addressed. This is the only thing the processor has to do in the HOLD state. The display controller (IC6) ensures that the read-out remains fixed.

The display section is a completely independent part of the circuit. The ASCII data that must be displayed is sent to the controller IC by the processor. This information is then stored by IC6, which also takes care of driving the display. The processor only intervenes by transmitting new data if the displayed information has to be changed.

8

microprocessor-controlled frequency counter

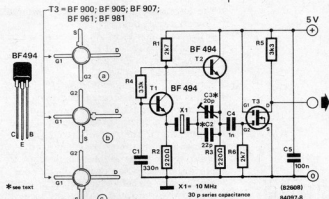

The power supply section seen in figure 6a shows that several different voltages are needed. A heating voltage of 6 V a.c. is fed to the fluorescent display from one of Tr1's windings. The same transformer provides a zenered -24 V d.c. that is also used for the display. The remainder of the circuit is powered by the regulated 5 V line. Two more supply voltages (U+ and -5 V) are needed for the input stage. The diagram shows a single mains transformer with a total of three secondary windings but the same effect can be achieved with two or with three separate transformers.

The crystal oscillator

The crystal oscillator is a very important part of the frequency counter as it determines the accuracy to a large extent. The design used is shown in figure 8. The crystal is in series resonance as this guarantees quite good stability. Both sides of the crystal are terminated into a low impedance in order to prevent its Q factor from being unnecessarily reduced. The MOSFET at the output acts as a buffer between oscillator and frequency meter. This oscillator circuit has been fitted to a separate small printed circuit board, and there is a good reason for this. The oscillator shown is quite acceptable but a very precise, temperature-stable crystal oscillator is needed to achieve an accuracy of six or seven digits. A cautious estimate gives the oscillator of figure 8 a stability of at most 10 ppm (parts per million) in a temperature range of 15 to 35 °C. This means that the accuracy is far from optimal but it is good enough for the average hobbyist especially as the temperature within the case will settle down to a constant value within quite a short time. Some people will, of course, demand that measurements be accurate to six or seven digits. This can be achieved by substituting a special temperature-compensated oscillator in place of the one shown here. Such an oscillator will be expensive but it can easily be incorporated into this frequency counter.

Figure 8. The circuit for the crystal oscillator is straightforward. Two transistors, T1 and T2, look after the low-impedance terminations for the crystal and a third one, T3, acts as a buffer.

A self-testing circuit

The frequency meter is made up of three printed circuit boards:

- the main board, which is double sided with through-plated holes
- the display board, and
- the crystal oscillator.

The first to be built is the crystal oscillator (if it is used). The series capacitance indicated in figure 8 is needed if the crystal has a capacitance of 30 pF. The capacitor and trimmer will have to be changed if different crystals are used. (Keep the trimmer as small as possible to prevent deterioration caused by its poor temperature stability.) The circuit is connected to a regulated supply and tested to see if the oscillator is supplying a 10 MHz signal. The output is probably distorted but this does not matter as it is caused by the capacitive load of the probe. A 10 MHz oscilloscope is needed during construction of the frequency counter so this is something you will have to get your hands on.

The next part to be tackled is the main printed circuit board, starting with the discrete components. Some of the capacitors and resistors (and one diode) must be mounted vertically. Sockets (preferably low-profile types) should be provided for all ICs, which must not be fitted yet. The eight lines indicated as K3 can be fitted with soldering pins. One of the voltage regulators, IC21, is connected to the board by means of three thick flexible leads about 10 or 11 inches long (roughly 25 cm). A pair of capacitors, C12 and C13, solder directly to the IC's pins. This regulator is not fitted with a heat sink but rather mounts straight onto the back panel of the Verobox. The heat generated is conducted through the metal plate and to aid this process silicone grease should be applied between voltage regulator and back panel. The photographs show where and how this IC must be fitted.

The mains transformer possibilities have already been mentioned but one point to note is that the case recommended does not leave a lot of room to play with. The fewer and the smaller the transformers the better they can be fitted into the available space. The 10 V winding is first soldered to the board and the output of IC20 is measured. This should be 5 V. The 24 V winding is now connected and the appropriate voltages measured: -5 V at pin 7 of K3 and -24 V at pin 19 of K2. The oscillator board can now be mounted on the main board. Be particularly careful to prevent short circuits between the 5 V copper track and the ground connection to the oscillator board. The U_v connection is not used by the Elektor oscillator. It provides an unregulated 9...12 V d.c. for crystal oscillators that need more than the +5 V we have used.

Two of the ICs, IC18 and IC19, are now fitted to their sockets. A square wave of 1 MHz should be present at pin 12 of IC18. Hexadecimal number \$AA must then be set on the data bus by means of eight 10 k resistors as shown in the margin here. The resistors are temporarily soldered to connector K1 and the 6502 can then be inserted into its socket. When the power is switched on again there should be a square wave of 250 kHz on address line A0, 125 kHz on A1, 62.5 kHz on A2, and so on down to 7.6 Hz on A15. This is easily checked with the oscilloscope as the period doubles each time. All address lines are available at connector K1. If the frequencies are not correct or if they are simply not present check pin 40 of IC15 (RES), which should be '1'. Similarly NMI and IRQ should be '1'. On pin 39 (Φ2) there should be a (rounded) 1 MHz square wave. If there are signals on the address bus, but not the correct ones, it is possible that the 10 k resistors are not properly connected and that something other than \$AA (10101010) is present on the data bus. A further, ever-present, possibility is that an address line may be shorted to another line.

The resistors are left where they are and IC8 and IC14 are fitted. Outputs '0...7' of IC8 should then in turn become logic zero for 16.4 ms. Pin 9 of IC14 must become '0' at the same time as pin 4 of IC8 and the same applies for pin 5 of IC14 and pin 5 of IC8. If this checks out the 10 k resistors can be removed.

Now we move on to the display section but first the heating voltage for the filament must be measured. Connect 330 Ω across the transformer's 6 V winding and measure the a.c. voltage across the resistor. It will usually be a little higher than 6 V. The series resistance needed to give a voltage drop of 5.8 V across the 330 Ω resistor can be calculated from the formula: $R = u \times 87 - 330$, where u is the voltage measured. Divide the result by two and use the nearest E12 or E24 value

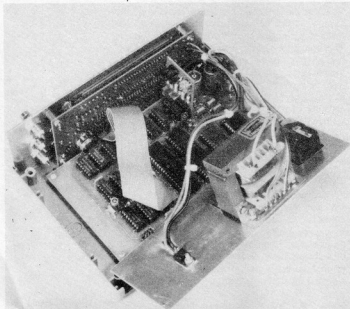
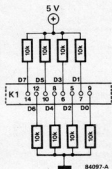

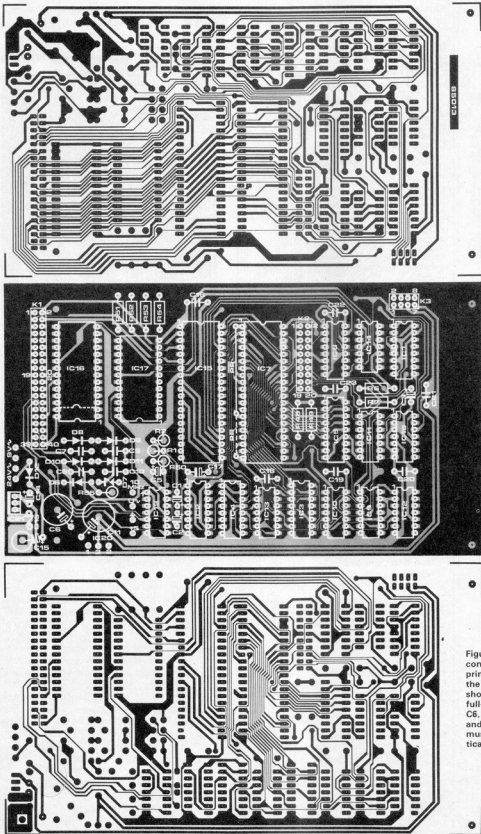

Figure 9. Due to space considerations the main printed circuit board for the frequency counter is shown here at 70% of full-size. Note that C3, C5, C6, C11, C14, C15, D13 and some of the resistors must be mounted vertically.

for R9 and R42 on the display board.
The display board can now be assembled
except that the display itself and IC6
should not yet be fitted. Do not use a
socket for IC6. Note that the tops of the

LEDs should extend 12 mm above the
board and that transistor T2 is laid flat on
top of the board. Use as thin a capacitor
as possible for C4 or fit it on the reverse
side of the printed circuit board. The

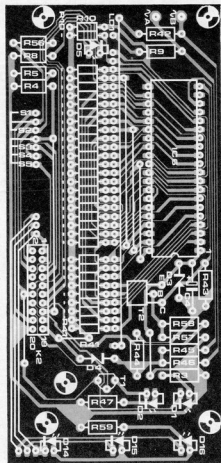
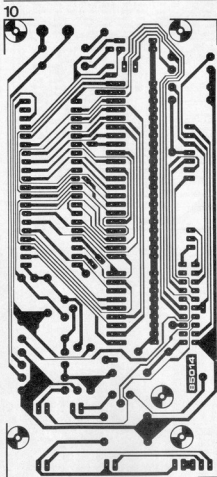

Figure 10. The display section is fitted on this printed circuit board. The 16-digit alphanumeric display is soldered straight onto the board and only bent back after testing is complete.

Parts list

— Main board and display board

Resistors:

- R1, R2 = 100 k
- R3, R47, R59 = 390 Ω
- R4, R5, R51...R54, R57 = 2k2
- R6 = 5k6
- R7, R8 = 220 Ω
- R9, R42 = *
- R10...R41 = 100 k, 1/8 W
- R43 = 22 k
- R44...R46, R50 = 1 k
- R48, R49, R56, R58 = 10 k
- R55 = 680 Ω

Capacitors:

- C1, C2 = 0.47 μ/10 V Ta
- C3, C14 = 47 μ/10 V
- C4 = 10 μ/25 V
- C5 = 100 μ/10 V
- C6 = 470 μ/40 V
- C7...C10 = 47 n
- C11 = 1000 μ/25 V
- C12, C13 = 4.7 μ/25 V Ta
- C15 = 47 μ/40 V
- C16, C18...C23 = 100 n
- C17 = 10 μ/10 V Ta

Semiconductors:

- D1 = LED, 5 mm yellow
- D2, D5, D14...D16 = LED, 5 mm red
- D3 = 15 V/400 mW zener
- D4 = 5V6/400 mW zener
- D6, D8...D12 = 1N4001
- D7 = 24 V/1 W zener
- D13 = 10 V/1 W zener
- T1 = BC547
- T2 = BC557
- IC1, IC4 = 74LS153
- IC2 = 74LS221
- IC3 = 74LS292
- IC5 = LS7060 (LSI)
- IC6 = 10937-50 (Rockwell — available from Regisbrook)
- IC7 = 6821
- IC8 = 74LS42
- IC9 = 74LS86
- IC10 = 74LS08
- IC11 = 74LS132
- IC12...IC14 = 74LS74
- IC15 = 6502
- IC16 = 2732
- IC17 = 6116
- IC18 = 74LS90
- IC19 = 74LS132
- IC20 = 7805
- IC21 = 7905

Miscellaneous:

- F1 = fuse, 100 mA slow blow
- LD1 = Futaba 16-digit alphanumeric fluorescent display, type number 16-SY-03(Z) (available from Regisbrook)
- S1...S5 = membrane switch in front panel foil
- S6 = miniature double-pole mains switch
- TR1* = mains transformer(s) 6 V/≥50 mA, 10...12 V/≥800 mA and 24 V/≥150 mA
- heatsink for IC21 connector for cable from front panel foil (7-way right angled, 2.54 mm/0.1" centres)
- Verobox no. 075-01411D (dimensions 205 × 140 × 75 mm)
- front panel no. 84097-F

* = see text

cable from the membrane switches in the front panel clips into the connector between R4 and K2. A length of 20-way ribbon cable about 7 inches (17 cm) long is soldered directly into the holes for connector K2 on the reverse side of the display board. The other end of the cable is then soldered directly to the main board (do not use soldering pins at either end). The numbers linked by each wire in the cable must, of course, be the same on both boards.

With the power switched on the voltages on the display board can be checked. There should be +5 V at pin 1 of IC6 and -10 V on pin 18. The d.c. voltage on the common line for R9...R41 should be -24 V. Switch the power off and solder IC6 directly onto the board. The pins of the display are pushed through the board until they extend by about 1 mm and are then soldered. Do not bend the display parallel with the board yet; until testing is complete it is left standing straight out like this. Returning to the main board IC16, complete with its program, is inserted into its socket. Switch the power on again and then touch the NMI line (pin 4 of K1) to ground for an instant. The self-test program in the EPROM then starts. The first function of this program is to test if it is itself correctly stored in IC6. If it is stop LED D5 lights for about 1 s to show that all is in order. If the LED remains out the EPROM is probably incorrectly programmed or one of its pins is not making proper contact. This assumes, of course, that the LED is fitted properly and that the wiring between the two boards is also correct.

After D5 has lit up the power can be fitted switch off to enable IC7 to be fitted into its socket. The power is turned on again and the '0' pulse is again applied to the NMI line. Each of connections PA0...PA7 then goes high for 1 s in turn so LEDs D2, D14, D15 and D16 start flashing (on for 1 s and off for 8 s). There is also a '1' running through lines PB0...PB6 (except for PB4). Provided the '1's keep running and the LEDs flashing the circuit is correct so far. Otherwise check IC7's socket to ensure that all the pins of the chip are inserted correctly. Next it is IC17's turn to be fitted. Substitute a wire bridge for S3 on the display board so that the circuit thinks that this push button is pressed continuously. Power is again applied to the circuit and the NMI line momentarily grounded. The gate LED should light for a short time. If this does not happen there is something wrong in (or with) the RAM. The gate LED may also fail to turn off and the stop LED may light and if this happens it indicates a problem, probably a programming error, in the EPROM.

It may be an advantage at this stage to see exactly what the test program does. If switch S3 is closed (or bridged) and NMI receives a short '0' pulse the program tests itself and lights the stop LED for about one second. The microprocessor then examines PB7. If this line is '1' the

PIA is then tested but if it is '0' (as it is when S3 is bridged) the RAM test procedure is started. This involves copying the contents of the EPROM to the RAM and then comparing what is stored in both. Assuming this test gives a positive result the gate LED lights briefly. Immediately after this the EPROM is tested: all the bytes are summed and a checksum byte is added. The result must be \$00. Any other result indicates one or more faults in the EPROM and the stop LED then lights. The power can now be switched off and the short circuit for S3 removed, as can the wire used to provide pulses to the NMI line. Connect the 6 V winding of the mains transformer to the display board. When the power is now switched on the display shows the text OVERFLOW, PLEASE RESET or FREQ. X.XXXXX HZ. This is an indication that the display board is correct. If nothing appears on the display the connections to the display board from the main board and from the transformer should be checked. Test also that the 6 V a.c. is present. Remove the power again and install the remaining ICs into the main printed circuit board. The cable from the front panel can also be plugged into its connector. (This cable is actually a thin plastic 'tail' with the wires from the front panel's switches embedded into it.) Treat the ICs carefully, especially the 74LS292 which is very sensitive.

Once again the power is applied to the circuit. The display should show FREQ. 0.000000 HZ. Press the menu button once and the NO button three times. The display is now EVENT COUNT? Press the YES button three times and the display will indicate TOTAL 0. Apply a square wave (about 1 Hz) at TTL level to pin 2 of K3 and measure if this signal is also present on pin 9 of IC1, pin 3 of IC9, pin 7 of IC4, pin 8 of IC9 and pin 1 of IC5. Both pin 6 of IC9 and pin 2 of IC5 should be zero.

If the circuit is working correctly each incoming pulse will be added to the total shown on the display. The trigger LED should also flash with each pulse and the gate LED should light continuously. If this does not happen the problem is almost certainly to be found in or around IC5. All the frequency meter's functions should now operate properly. Doubting Thomases can check this by comparing signals at various points in the circuit with the appropriate timing charts.

Casing the circuit

Before any part of the circuit can be fitted into the case the necessary ventilation holes must be drilled in both upper and lower sections. Assuming the recommended type of box is used the main printed circuit board will fit snugly inside parallel to the bottom and can be fixed to the mounting bosses with self-tapping screws. An insulating ring must be placed under the bolt beside K1. The mounting boss at the front left-hand corner of the

11

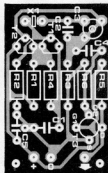

Figure 11. The small size of the printed circuit board for the crystal oscillator belies its importance. This is what makes the microprocessor tick.

Parts list

— Crystal oscillator

Resistors:

- R1, R6 = 2k Ω
- R2, R3 = 220 Ω
- R4 = 33 k Ω
- R5 = 3k Ω

Capacitors:

- C1 = 330 n
- C2* = 22 p
- C3* = 20 p trimmer
- C4 = 1 n
- C5 = 100 n

Semiconductors:

- T1, T2 = BF494
- T3 = BF900, BF905, BF907, BF961, BF981

Miscellaneous:

- X1* = 10 MHz crystal with 30 p series capacitance

* = see text

top of the case must be removed so that the surface here is completely flush. The attractive finished appearance and correct operation of the meter can only be assured if the front panel foil available through Elektor's EPS service is used. It is an essential part of the circuit as it contains the membrane switches used to control the frequency counter. This foil is quite thick so the slots provided in the case to accommodate the metal panel supplied with the box will be too thin to accept both of these at the same time. For this reason a sheet of aluminium about 1 mm thick and with the same dimensions as the front plate supplied must be used instead. Use the template provided with the front panel foil to drill all the necessary holes in the new front plate. The display board can be fixed to the plate by means of four countersunk bolts or with four bolts stuck to the inside of the panel. The locations for these holes or bolts are indicated by the template and it is important to note that the bolts may not protrude by more than 15 mm. The holes for the BNC sockets are drilled undersize and then filed to the right shape and size. One side of each hole is flat so the sockets cannot turn. The slot for the front panel cable must also be cut and then a final check made to make certain that everything fits as it should. The backing paper can now be taken off the front panel foil. Pass the cable through the slot and then stick the foil carefully and accurately onto the aluminium front plate. Any excess foil should now be cut off with a sharp knife. There is a thin layer of protective plastic on the front of the foil that can be removed when the case is completely finished.

The wires to the mains switch can now be soldered in place. Note that they must rise straight up from the switch as otherwise they might foul the capacitors on the

display board. (The sketch in the margin here indicates what we have in mind.) Insulate the connections very well, with short lengths of heat-shrink tubing, for example.

All the components must now be fixed to the front panel. A 10 k potentiometer must be fitted to the hole left in the display printed circuit board. The type used should ideally have small dimensions and an insulating washer must be used at the copper side of the board. This potentiometer will be used later — when the input stage is added to the meter. Bend the display carefully towards the board and over IC6. Do this correctly and the display will fit exactly in the window in the front panel. Fix the display board to the front panel by means of the bolts already discussed.

The mains transformer is now fixed to the rear panel of the case so that its mounting bracket is about 2 mm below the top of the box. Fit the transformer above IC16, IC7 and IC17 in order to leave room for the input stage next month. Also fitted to the back panel is IC20 and in this case some heat-conducting paste must be used between IC and metal. The mains cable, naturally enough, feeds through the back panel, preferably by means of the chassis plug and socket arrangement normally used for laboratory test instruments. Before screwing the top onto the case a heatsink must be fitted onto IC21.

The oscillator in the circuit can only be correctly calibrated with reference to another (accurate) frequency counter. Measure the frequency at pin 1 of IC18 and use the trimmer to set this to exactly 10 MHz. Fit the top onto the case and leave the meter on for about half an hour. Measure the frequency again and if necessary re-trim C3.

The constructional details of this frequency counter have been dealt with in much more detail than is usual in our circuits. We felt that this was necessary as it is a very important test instrument and the instructions given should enable any hobbyist to build a working example. Next month we will describe the input amplifier with the prescaler. All of the counter's functions are self-explanatory and selection is simplicity itself but it is always useful to familiarise yourself with any new equipment by experimenting with it. ■

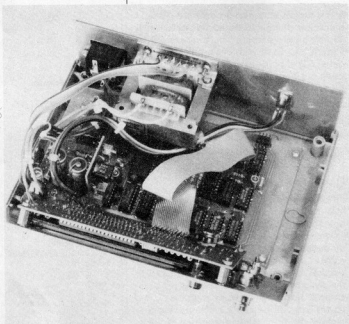
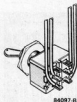

Table 2. This hexdump is the program that tests, drives and controls the frequency counter circuit.

CMOS function generator

The aim of this project was to produce a simple, cost-effective, general purpose audio generator, which was easy to build and use. This aim has certainly been achieved, since the circuit offers a choice of sine, square and triangle waveforms and a frequency range from about 12 Hz to 70 kHz, yet uses only one CMOS hex inverter IC and a few discrete components. Of course, the design does not offer the performance of more sophisticated circuits, particularly as regards waveform quality at higher frequencies, but it is nonetheless an extremely useful instrument for audio work.

Block diagram

Figure 1 illustrates the operating principles of the circuit. The heart of the generator is a triangle/squarewave generator consisting of an integrator and a Schmitt trigger. When the output of the Schmitt trigger is high, the voltage fed back from the Schmitt output to the input of the integrator causes the integrator output to ramp negative until it reaches the lower trigger threshold of the Schmitt trigger. At this point the output of the Schmitt trigger goes low, and the low voltage fed back to the integrator input causes it to ramp positive until the upper trigger threshold of the Schmitt trigger is reached. The output of the Schmitt trigger again goes high, and the integrator output ramps negative again, and so on. The positive- and negative-going sweeps of the integrator output make up a triangular waveform, whose amplitude is determined by the hysteresis of the Schmitt trigger (i.e. the difference between the upper and lower trigger thresholds). The output of the Schmitt trigger is, of course a square wave consisting of alternate high and low output states.

The triangle output is fed through a buffer amplifier to a diode shaper, which 'rounds off' the peaks and troughs of the triangle to produce an approximation to a sinewave signal.

Any one of the three waveforms may then be selected by a three-position switch and fed to an output buffer amplifier. The frequency of all three

Using only one inexpensive CMOS IC and a handful of discrete components, it is possible to build a versatile function generator that will provide a choice of three waveforms over the entire audio spectrum and beyond.

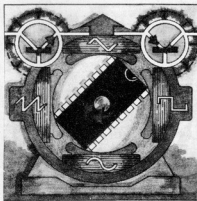

signals is varied by altering the integrator time constant, which changes the rate at which the integrator ramps, and hence the signal frequency.

Complete circuit

The practical circuit of the CMOS function generator is given in figure 2. The integrator is based on a CMOS inverter, N1, whilst the Schmitt trigger uses two inverters with positive feedback, N2 and N3.

The circuit functions as follows; assuming, for the moment, that the wiper of P2 is at its lowest position, when the output of N3 is high a current

$$\frac{U_b - U_t}{P_1 + R_1}$$

flows through R1 and P1, where U_b is the supply voltage and U_t is the threshold voltage of N1. Since this current cannot flow into the high impedance input of the inverter, it all flows into C1 or C2 (depending on which is selected by S1).

The voltage drop across C1 thus increases linearly, so the output voltage of N1 falls linearly until the lower threshold voltage of the Schmitt trigger is reached, when the output of the Schmitt trigger goes low. A current

$$\frac{-U_t}{P_1 + R_1}$$

now flows through R1 and P1. This current also flows into C1, so the output voltage of N1 rises linearly until the upper threshold voltage of the Schmitt trigger is reached, when the output of the Schmitt trigger goes high and the whole cycle repeats.

To ensure symmetry of the triangle waveform (i.e. the same slope on both positive-going and negative-going portions of the waveform) the charge and discharge currents of the capacitor must be equal, which means that $U_b - U_t$ must equal U_t . Unfortunately U_t is determined by the characteristics of the CMOS inverter and is typically 55% of supply voltage, so $U_b - U_t$ is about 2.7 V with a 6 V supply and U_t is about 3.3 V.

This difficulty is overcome by means of P2, which allows symmetry adjustment. Assume for the moment that R4 is connected to the positive supply rail (position A). Whatever the setting of P2, the high output voltage of the Schmitt trigger is always U_b . However, when the output of N3 is low, R4 and P2 form a potential divider so that a voltage from 0 V to 3 V can be fed back to P1, depending on the wiper setting of P2. This means that the voltage across R1 and P1 is no longer $-U_t$ but

economical crystal time base

a 50 Hz 'bench mark'

This time base circuit is built using normal readily available CMOS ICs and a cheap crystal. The circuit gives the constructor the possibility of 50 Hz, 100 Hz or 200 Hz. The 50 Hz reference frequency is an ideal time base for the construction or calibration of electronic clocks, frequency meters and so on. Because of the flexible supply voltage requirement, it is also a good basis from which to build a digital clock for the car.

IC1 contains an oscillator and a 2^{14} divider. Providing the oscillator loop is correctly calibrated using C2, the output at pin 3 (Q14) will produce a 200 Hz square wave. With the help of the two flip-flops in IC2

Parts list

Resistors:

R1 = 10 M
R2 = 100 Ω

Capacitors:

C1 = 22 p
C2 = 2... 22 p trimmer
C3 = 10 μ 16 V

Semiconductors:

IC1 = 4060
IC2 = 4013

Miscellaneous:

X = 3.2768 MHz crystal

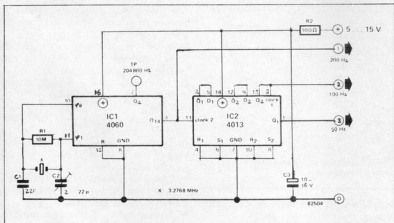
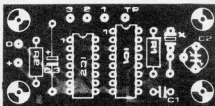
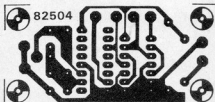

this square wave voltage is then divided by two and then by four resulting in two further outputs of 100 Hz and 50 Hz, the latter from pin 1. Readers who have a frequency meter can calibrate the circuit by simply connecting the meter to pin 7 of IC1 (Q4) and adjusting C2 until a reading of 204,800 Hz is indicated. As a matter of interest, anyone without a frequency meter should not despair since setting trimmer C2 to about midway will provide sufficient accuracy for most applications. The 100 Hz output is useful for the construction of digital counters. For this purpose we suggest that a 1 : 10 divider (like the 4518) is connected to the 100 Hz output pin. The power supply requirements are: from 5... 15 V and 0.5... 2.5 mA. **M**

low voltage stabiliser

battery powered voltage regulator

Depending on their condition 1.5 V batteries supply a voltage of 1.2... 1.7 V. This circuit can be very useful when a project has to be fed with a constant, low voltage. With an input voltage of 1.2... 1.8 V this stabiliser produces a relatively constant voltage of 1.15 V with a maximum load of 5 mA. T2 cuts off at a minimum battery voltage of 1.2 V with a load of 5 mA. The output voltage tends to increase with a higher battery

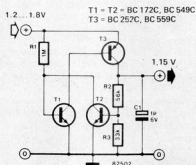

voltage, causing T2 to conduct and reducing the base current of T1 and T3 (indirectly), so that the output voltage will remain 1.15 V. The internal impedance of this low voltage supply is 1 to 2 Ω . The output voltage will only be reduced by 70 mV when changing the battery voltage from 1.8 V to 1.2 V. **M**

(ITT application)

When deciding which capacitors to use, consideration should be given to reliability, the permissible range of operating conditions, size and so on. Size is important especially when building high density circuits, and last but not least price. Keep in mind, that, any need for special current limiting resistors is going to increase the overall cost of using tantalums. Even so, tantalum capacitors are used widely, where the operating characteristics of the capacitor is critical. Quite a few Elektor circuits specify the use of tantalums, and not just because they are small and good to look at. They have a stable capacitive value, and a long shelf life. The impedance is virtually unaffected by frequency changes. So, on the face of it tantalums are ideal. However, they do have one major drawback; price!

applications, and certainly fell down, for high frequency designs.

From the offset for many applications the tantalums did not have too much competition, and with the craze for miniaturisation they filled a need straight away. The biggest factor initially in favour of tantalums was this question of shelf life. Even after years of storage, their current leakage, and value remain unchanged. In fact their shelf stability is about 100 times better than the wet aluminium type.

Apart from everything so far explained the tantalums were not embarrassed by temperature. The wet electrolytics are affected quite considerably by temperature, causing large increases in the leakage current level. It is this failure to dissipate heat that causes their mediocre conductance.

electrolytics run dry

everything you wished to know!

So far for many industrial and professional applications wet electrolytics and tantalums have ruled the roost. With new innovations and technological advancements, it is now possible to use alternatives which can be cheaper and more reliable. Many factors need consideration when making the right choice, and a good knowledge of the merits and limitations of the different types available is useful.

In fact a comparison shows that the new solid aluminium electrolytics, can be used as alternatives for tantalums, and in many respects can be seen to be better.

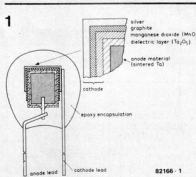

Figure 1. Diagram of the structure of tantalum electrolytic.

With such an incentive as this, some type of alternative was needed.

With the constant improvement in technology, coupled with energy saving and the conservation of natural resources, many experts started to question the sanity of using tantalum for capacitors. Tantalum is now in limited supply, as with everything else, and its price is increasing by leaps and bounds. So, why use tantalums?

We must first of all keep in mind that at the time that they emerged onto the market, the only other type, with which they could be compared, were the wet aluminium electrolytics. These were and still are inexpensive, but are generally larger than any solid counterpart and suffered from a relatively short shelf life. By this we mean, that after long storage, their leakage current increases, and can only be restored to its original value by post-forming. Also, if they are used close to their maximum operating temperature, their life expectancy, which is normally far less than solid types, is curtailed even more. The wet type could not be used in certain new

By comparison the tantalums have a wide operating range as far as temperature is concerned, making them suitable for filters and oscillators. Hence the reason why they are widely used in Elektor designs.

Most of you by now must probably think that the writer must be completely sold on tantalums. Not so! They do have, what can be termed as inconveniences, rather than faults or disadvantages:

- The voltage level they can sustain when connected the wrong way round is extremely small, even for a very short interval. They breakdown rapidly and can explode easily.
- Their a.c. voltage performance is poor and further diminished at high frequencies and temperatures.
- The charge/discharge rate resistance is $3 \Omega/V$, making it necessary to use series resistors.
- A surcharge, whether it is of a thermo, current, or voltage nature, will cause immediate breakdown, short circuiting and a possible explosion.
- The price of each item is quickly approaching prohibitive levels.

All in all tantalums are certainly not perfect, mind you what is these days! Should series resistors not be used in order to limit the charge/discharge rate, then the results are always fatal. This is because field crystallisation will occur, causing short circuiting.

At the beginning of the article we explained all the advantages of using tantalums; impedance, heat dissipation, life span, high frequency performance and so on. But, it seems that it did not take us very long to arrive at the conclusion that even these are not as good as we would wish. As with many things, it is a fact of life that the more you use something the less appealing it becomes. Notice that we do not say everything,

since the good things in life are always welcome.

Luckily the capacitor manufacturers have not stood still and have come up with a relatively new development. Using deeply-etched foil an axial-lead solid aluminium electrolytic has been created, achieving a high CV density making them less expensive replacements for tantalums. Although they are not going to displace the latter completely, they will be very widely used in a variety of industrial and professional equipment.

Solid aluminium capacitors

The solid aluminium electrolytic has a comparable performance with the tantalum type, but not only is it cheaper, but it does have a few advantages. Figure 1 shows the different com-

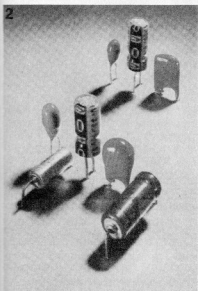

Figure 5. Stability of the main electrical parameters of the three types of electrolytic as a function of time. The curves are for a 0.1 μ F item measure at 85°C.

ponents which go to make a tantalum. There are a lot of similarities in construction with the solid aluminium type (SAL). Looking at figure 1, you will note that the former has layers of silver, graphite and manganese dioxide (MnO_2) which form the cathode. Then comes a dielectric layer and finally the anode made of tantalum. This is sintered to the tantalum oxide (dielectric layer).

Figure 3 shows the make up of a SAL. The cathode is composed of the same materials as the tantalum. The real difference between the two lies in the fact that, the anode is composed of deeply etched aluminium and that the dielectric layer is aluminium oxide Al_2O_3 . Hence the remarkable conductivity of the solid aluminium electrolytic!

These SALs, to coin a phrase, are very robust to say the least. They can operate near their maximum temperature ratings

3

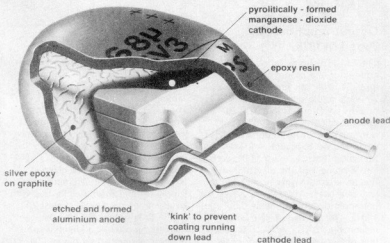

Figure 3. Structure of a solid aluminium electrolytic.

4

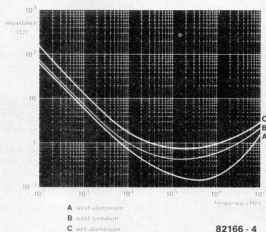

Figure 4. Impedance as a function of frequency with capacitor type as a parameter. All capacitors are 33 μ F, 10 V.

without shortening their life span, and do not have any catastrophic failure mechanism. In other words they are not going to blow-up in your face at the wrong moment. An added bonus is the fact that series resistors are not needed. The values already available are in the range 47...1000 μ F and one major manufacturer has proposed to make smaller ones with 0.22...47 μ F, but, it may take some time before these are available.

They are slightly larger than their equivalent counterparts, and although being less expensive than tantalums they are marginally more costly than the wet type.

Present applications include telecommunications, space programs, and power stations. Their small size and robustness make ideal for the automobile industry. Because they are being improved upon all the time, a rosy future lies ahead of

them.

To summarise the main characteristics of the SAL are:

- Lower price.
- Their voltage rating remains unchanged throughout the operating range, even at high temperatures (-80 to 175°C).
- The allowed d.c. voltage (reversed) is around 33% of their rated voltage.
- Does not require current limiting.
- a.c. voltages (up to limits) can be handled and do not adversely affect their performance.
- Their impedance fall more steeply with increasing frequency than any other type.
- They can withstand 50/100 Hz a.c. voltages up to a level which is 80% of their d.c. rating.
- Temperature stable, and low failure rate coupled with longevity.

Output amplifier IC Type LM 1875

The LM 1875 from National Semiconductor is a monolithic output amplifier that can provide up to 20 watts audio power of excellent quality. It is housed in a TO-220 encapsulation in which you would normally expect no more than a small voltage regulator.

Maximum output power is 35 watts into 8 ohms, but the distortion at this level is no longer acceptable for hi-fi purposes. At 20 W, however, the harmonic distortion is only 0.05% at 1 kHz. The bandwidth is a very reasonable 70 kHz, while the slew rate of 8 V/ μ s is excellent for this

type of IC. Other plus points are the very good hum suppression of 94 dB, the thermal protection circuit, and the short-circuit protection. Further characteristics are given in Table 1.

The LM 1875 has five connecting pins: two for the supply voltages (positive and negative), one for the output, and two for the inputs (inverting and non-inverting). Two possible circuits are given in figure 1: one with a symmetrical supply (a) and the other for use with an asymmetrical power supply (b). Figure 1a is noteworthy for the minimal number of additional components required: two diodes, D1

and D2, for the protection of the output transistors, high-pass filter C5/R5, input filter C1/R1, negative-feedback network R2/R3/R4/C2, and decoupling capacitors C3 and C4.

The gain, A, is determined by $A = 1 + R4/R3$.

The characteristics in figure 2 show the total harmonic distortion, THD, versus power output and frequency and the power output versus the supply voltage.

Because of its small dimensions, the quality of the output, and the small number of external components required, this IC is eminently suitable for use in active loudspeaker systems.

Table 1

Absolute Maximum Ratings

| | |
|--|-----------------------|
| Supply Voltage | ± 30 V |
| Input Voltage | $-V_{EE}$ to V_{CC} |
| Operating Temperature | 0°C to +70°C |
| Storage Temperature | -65°C to +150°C |
| Junction Temperature | 150°C |
| Power Dissipation (Note) | 30 W |
| Lead Temperature (Soldering, 10 seconds) | 300°C |

TO-220 Power Package (T)

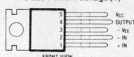

Electrical Characteristics

$V_{CC} = 30$ V, $-V_{EE} = -30$ V, $T_{TAB} = 25^\circ$ C, $R_L = 8 \Omega$, $A_V = 32$ (30 dB), $f_o = 1$ kHz, unless otherwise specified.

| Parameter | Conditions | Min | Typ | Max | Units |
|---|------------------------------------|------|---------|-----|------------|
| Supply Current | $P_{OUT} = 0$ W | | 60 | 100 | mA |
| DC Output Level | | | 0 | | V |
| Output Power | THD = 1% | | 30 | | W |
| THD | $P_{OUT} = 20$ W | | 0.05 | | % |
| | $P_{OUT} = 20$ W, $f_o = 20$ kHz | | 0.2 | 0.4 | % |
| | $P_{OUT} = 30$ W | | 0.1 | | % |
| | $P_{OUT} = 30$ W, $f_o = 20$ kHz | | 0.4 | 1.0 | % |
| | $P_{OUT} = 20$ W, $R_L = 4 \Omega$ | | 0.06 | | % |
| $P_{OUT} = 20$ W, $R_L = 4 \Omega$, $f_o = 20$ kHz | | 0.3 | 0.6 | | % |
| Offset Voltage | | -30 | ± 5 | 30 | mV |
| Input Bias Current | | -5 | -2 | 5 | μ A |
| Input Offset Current | | -1.5 | 0 | 1.5 | μ A |
| Input Sensitivity | $P_{OUT} = 20$ W, $f_o = 20$ kHz | | 400 | 450 | mVrms |
| Open Loop Gain | | | 90 | | dB |
| PSRR | V_{CC} , 120 Hz, 1 Vrms | 52 | 93 | | dB |
| | $-V_{EE}$, 120 Hz, 1 Vrms | 52 | 95 | | dB |
| Max Slew Rate | | | 8 | | V/ μ s |
| Current Limit | | 3 | 4 | | A |
| Equivalent Input Noise Voltage | $R_g = 600 \Omega$, CCIR | | 3 | | μ Vrms |

Note: Assumes T_{TAB} to 60°C max. For operation at higher tab temperatures and at ambient temperatures greater than 25°C, the LM 1875 must be derated based on a maximum 150°C junction temperature. Thermal resistance depends upon device mounting techniques.

Table 1. Absolute maximum ratings and electrical characteristics.

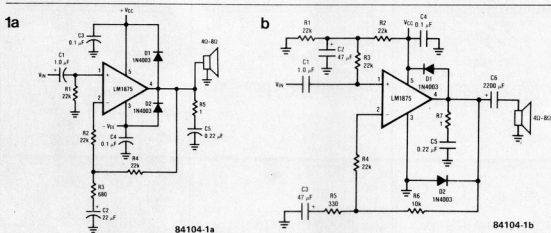

Figure 1. Two possible circuits for an output amplifier based on the LM 1875: one for use with a symmetrical power supply (a) and the other for an asymmetrical supply (b).

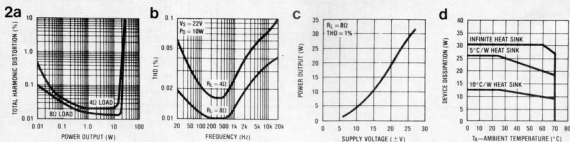

Figure 2. Total harmonic distortion versus power output (a); total harmonic distortion versus frequency (b); power output versus supply voltage (c); internal dissipation versus ambient temperature (d).

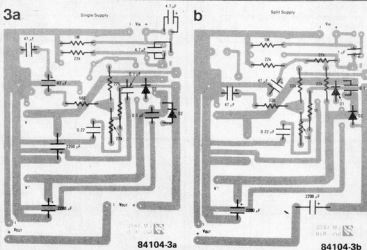

Figure 3. Printed-circuit layout of the two suggested circuits of figure 1: (a) with symmetrical and (b) with asymmetrical power supply.

Literature:
National Semiconductor:
Preliminary Application
Note on the LM 1875

National Semiconductor addresses:
United Kingdom:
301 Harpur Centre
Home Lane
Bedford
Phone: (0234) 47147

Denmark:
Bianco Lunos Alle 1
1868 Copenhagen V
Phone: (01) 213211

Southern Europe:
Via Solferino 19
20121 Milano
Italia
Phone: (02) 6596146

Spain/Portugal:
c. Agustin de Foxa 27 (9 d.)
E-Madrid 16
España
Phone: (01) 7332954

Northern Europe:
Postadress Box 2016
S-127 02 Skärholmen
Sverige
Phone: 08-970190

Outside Europe:
2900 Semiconductor Drive
Santa Clara
California 95051
USA
Phone: (408) 721-5000

SOLDERING STATION

The SOLDEX soldering station has been developed specially for soldering micro electronic components like LSI chips, MOS devices and other sensitive components. The bit tip size range is 1.5, 2.5 and 3.5 mm diameter, for precision soldering work. The construction is slip in type and provides easy interchangeability.

The station contains a soldering stand and the bit is positively connected to the earth pin of the power plug to prevent static build up.

Nominal power consumption is 25 watts, but the circuit can draw up to 50 watts if necessary. The soldering iron weighs 95 gms.

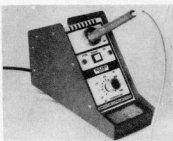

For further information, write to:
Thermal Sensors
37, Electronics Complex,
Kushaiguda,
Hyderabad 500 762

MICRO ANALYSER

Electronumerics have introduced EN 85, a system analyser for software development, testing and trouble shooting of 8-bit systems based on 8085, Z-80 etc.

The EN 85 is a compact unit with stand alone capability and is useful for manufacturing industries as well as in field applications. This analyser system is used to examine and modify the memory locations, execute the programme upto a particular address and stop or step through a programme one instruction at a time or one machine cycle at a time.



For further information, write to:
Electronumerics
Kammagondnahalli,
Opp. HMT Industrial Estate
Jalahalli (West)
Bangalore 560 015

DIGITAL MEGGER

Arun Electronics have developed a new insulation tester with digital readout. This fully solid state unit does not require any hand driven mechanism for generating test voltages. The instrument operates directly from the mains supply and has built-in DC to DC converters to generate the test voltages.

The measurement ranges available are 20, 2000, and 10000 Megaohms. Linearity is claimed to be 0.1% throughout the range.



For further information, write to:
Arun Electronics Pvt. Ltd.
B-125, Ansa Industrial Estate,
Saki Vihar Road, Saki Naka,
Bombay 400 072.

WIRE STRIPPER

Efficient Engineers have developed a thermal wire stripper which gives neat, clean and fast stripping of PVC and Mafcon coated wires, flat cables and Teflon coated cables.

This is an easy to use tool which does not require adjustments for varying wire diameters. It can strip wires with a wide range of diameters. A strip stop guide is provided to set the length of insulation to be stripped. The unit operates directly on mains supply.

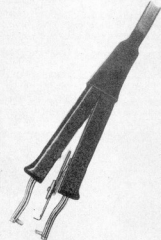

For further information, write to:
SAI Electronics
Thakore Estate, Kurla-Kiroli Road,
Vidyavihar (West), Bombay 400 086.

STEPPING MOTOR DRIVES

Spectron offers 'Ameya' stepping motor drives in 3 models.

The possible application areas are X-Y-Z, positioning and movement, Rotary and linear indexing, Feeders and length control, Flow control etc.

The range covers stepping speeds upto 5,000 steps/sec. driving upto 60 Kg-Cm torque rated stepping motors.

Standard controls such as Start/Stop, Direction selection, Jog/Slew selection and Deceleration Ramp and Linear step-rate control etc. are provided. Optional features are: Remote control, Single or Tandem drives, Indexing, Interface with microprocessor keyboard or Thumb wheel switches.

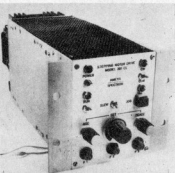

For further information, write to:
Spectron Sales and Service Pvt. Ltd
63, Bharatkunj No. 2 Erandwane,
Pune 411 038.

RELAY SOCKETS

Essen Deinki now introduce two new plug-in type relay sockets. The DS-08 is for 8 pin and DS-11 is for 11 pin configurations. These sockets can be snap mounted on DIN rail taking only 36 mm length of the rail. They can also be mounted on chassis using two screws. The body is moulded in flame retardant glass filled thermoplastic resin. Screw terminals are provided with captive U washers for secure wiring. Snap on receptacles can also be connected to the spade terminations after removing screws and washers.

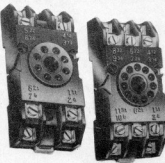

For further information, write to:
Essen Deinki
386, Industrial Area,
Chandigarh 160 002

DIGITAL MULTIMETERS

Digital Instruments Corporation have introduced three new models of digital multimeters, DM 520, DM 525, DM 555. All the models have three and a half digit, half inch LED/LCD display. The measurement ranges are AC/DC voltages from 200 mV to 600 V rms AC/1.2 KV DC, AC/DC currents from 200 μ A to 2 A and resistances from 100 milliohms to 20 megaohms. Input impedance is claimed to be very high. Model DM 525 has facility for optional external shunts. Models DM 520 and DM 525 have very high accuracy in AC measurement over the entire audio range of frequencies. All models are provided with autopolarity and decimal points, they are fully protected against overloads in all ranges.



For further information write to:
Digital Instruments Corporation
Near Tower, Saipur Bogha
Naroda Road, Ahmedabad-382 345

CONTACT CLEANER

Kli-Nit Contact cleaner CT-2 is now available with an extension for pin point application on the inaccessible electrical contacts. Kli-Nit contact cleaner CT-2 when sprayed, not only cleans the contact but also reduces arcing as well.

The product is now available in 250 ml and 350 ml aerosol containers to suit the requirements of different users.



For further information, write to:
Haktronics Pvt. Ltd.,
Dadoji Kondde X Marg,
Bombay 400 027.

CLIMATE ANALYSER

Indoor Climate Analyser Type 1213 is a handy, easy to operate, portable instrument for evaluating all of the basic parameters which influence the thermal environment and its effect on human life.

The analyser has a 20 character alpha numeric display. It has five transducers which can measure air temperature, surface temperature, radiant temperature asymmetry, humidity and air velocity. The measurements are carried out and recorded automatically. Four different recording periods of 1, 6, 24, and 120 Hours are available. Measurements are spaced evenly throughout the recording period and the analyser can be left unattended.

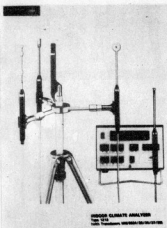

For further information, write to:
Jost's Engineering Co. Ltd.,
60, Sir Phirozeshah Mehta Road,
Bombay 400 001.

PRESS CLIPS

SEE press clips have unlimited uses in clamping applications. They offer a fast and easy way to hold cables and wires. The clips are provided with an adhesive backing for long lasting hold and are available in full or half styles. Material used for manufacture is claimed to be non conductive, non corrosive and resistant to most common solvents, alkalies, dilutes acids, petroleum oil and greases.

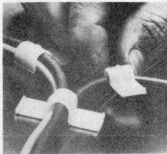

For further information, write to:
Suresh Electronics and Electronics
Manasarovar, 3 B, Camac Street,
Calcutta 700 016.

LINE FREQUENCY METER

The new line frequency meter from JIVAN Electro Instruments is based on the latest CMOS technology for high stability and noise immunity. The display is 4 digit, half inch seven segment LEDs.

The resolution is 0.01 Hz and the accuracy is claimed to be $\pm 0.1\%$ of the reading. The unit can be made available in two ranges of 99.99 Hz and 999.9 Hz. High and low alarm facility can also be provided.



For further information, write to:
JIVAN Electro Instruments
394, G.I.D.C. Estate,
Makarpara,
Baroda 390 010.

MINIATURE HIGH-V RELAYS

Kilovac Corporation have announced a complete new range of miniature High-Voltage relays. Available in SPDT, SPST, fail-safe and latching configurations, the range includes relays with ratings upto 10 KV. The light weight miniature relays are offered in low cost commercial version and also in a military version. They are suitable for application in digital antenna couplers, laser systems, medical instruments and several other industrial applications.

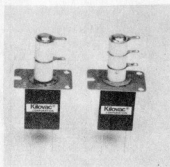

For further information, write to:
Toshni-Tek International
267, Kilpaik Garden Road,
Madras 600 010.

PARSER

(August/September 1984, page 8-94)

This program does not work on some computers but the situation can be improved by doing the following:
 remove lines 160 and 1110 copy lines 1000...1100 between 150 and 170 with line numbers from 151 to 161 line 151 ... THEN 1080 becomes... THEN 159 line 120 ... THEN 1090 becomes... THEN 160 line 140 ... THEN 1080 becomes... THEN 159.

capacitance meter

(March 1984, page 3-42)

The note in the margin on page 2-55 is incorrect. It should read:

Meter board:

P1 sets the display to '0' in range a
 P2 calibrates ranges a, b and c
 P3 sets display to '0' in ranges b...f

funny bird

(summer circuits, page 8-62)

T1 is drawn erroneously as an NPN type, whereas it is, of course, a PNP type.

FM pocket radio

(August/September 1984, page 8-53)

Transistor T6 must be BC 560C with the collector connected to +5 V.

valve amplifier

(December 1984)

Apparently not all the cobwebs were blown away before we finalised this article. The test voltage of -10.4 V given at pin 2 of the EL84s should, in fact, be 0 V. The -10.4 V referred to is the potential difference between cathode and grid rather than an absolute value.

burglar deterrent

(December 1984)

In figure 2 and the parts list R7 is given as 1 k/1/4 W. Depending on individual circumstances it may be necessary to change this for a value of 1 k/1 W.

ZX81 cassette pulse cleaner

(November 1984)

The first paragraph of the text states that a logic one is represented by eight pulses. This is incorrect; it should, in fact, read nine pulses.

real time analyser (part 1)

(April 1984, page 4-740)

The Voltage Regulators should be type 7812 and 7912 respectively as shown in the circuit diagram. Where the text and parts list read 7808 and 7809 this should be corrected to 7812 and 7912 respectively. Likewise, voltages of +8V and -8V should read +12V and -12V.

how to recycle dry batteries

(November 1984, page 11-58)

In fig. 5 the resistor mentioned as 220 ohms should actually be 2 k 2 ohms in the last sentence of the article the mention of S1 is incorrect it should be S2

anodizing aluminium

(October 1984, page 10-467)

We have been advised by a reader that caustic soda lye CAN be stored in glass bottles, provided they do not use a glass stopper: fitted with a screw plastic cap or rubber stopper they are perfectly satisfactory. If a glass stopper is used, carbon dioxide is gradually absorbed from the atmosphere (because the stopper is a poor seal) and the contents are eventually converted to sodium carbonate (washing soda). Furthermore, if caustic soda solution gets onto the ground glass of the glass stopper, this again is converted to sodium carbonate which can make the stopper quite unremovable in a matter of weeks.

alabyrinth

(April, 1984, Page 4-307)

The last address and data (800: FF) in the hexdump in table 1 should be deleted.

direct-coupled modem

(November 1984, Page 11-347)

It appears that the missing link in our November issue is still not the complete solution to FF3 setting inadvertently on switch-on. A satisfactory solution is to connect a 470 pF capacitor between pins 7 and 13 of IC7 and to ensure that C21 in positions TELEPHONE and MODEM is connected to earth via one of the unused sections of switch S2.

digital tachometer

(October 1984, page 10-35)

The formula given in the last part of the marginal note beside figure 2 (page 9-47) is not right. It should state:
 $f = 1/(2.2 \times C4 \times (R5 + P1))$.
 The frequency range is then 688...1194 Hz.

petrol saver

(April 1984, page 4-15)

In some cars, it may be advantageous to replace the part of the circuit shown in 1 by that in 2.

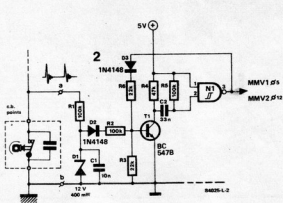
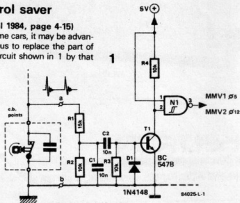

CONDITIONS OF ACCEPTANCE OF CLASSIFIED ADVERTISEMENTS

1) Advertisements are accepted subject to the conditions appearing on our current rate card and on the express understanding that the Advertiser warrants that the advertisement does not contravene any trade act in force in the country.

2) The Publishers reserve the right to refuse or withdraw any advertisement.

3) Although every care is taken, the Publishers shall not be liable for clerical or printer's errors or their consequences.

4) The Advertiser's full name and address must accompany each advertisement submitted.

The prepaid rate for classified advertisement is Rs. 2.00 per word (minimum 24 words). Semi Display panels of 3 cms by 1 column. Rs. 150.00 per panel. All cheques, money orders, etc. to be made payable to Elektor Electronics Pvt. Ltd. Advertisements, together with remittance, should be sent to The Classified Advertisement Manager. For outstation cheques please add Rs. 2.50

Electronics Tools like Soldering Irons, Pliers, Cutters, Screw Drivers, Tweezers at Competitive Prices. Contact Aradhna Electronics (P) Ltd., 10, Srinath Complex, Sarojinidevi Road, Secunderabad 500 003.

| | |
|--------------------------------|------------------|
| APPOINTMENTS | 2.70 |
| APLAB | 2.09 |
| BALAJI | 2.14 |
| COSMIC | 2.76 |
| DANNIES ELECTRONICS | 2.10 |
| EAGLEMAN ENTERPRISES | 2.06 |
| ELCIAR | 2.06 |
| ELCOT | 2.05 |
| ELECTRICAL INSTRUMENT CO. | 2.10 |
| ELECTRON | 2.13 |
| ELTEK | 2.04 |
| GEETA ELECTRONICS | 2.14 |
| IEAP | 2.06 |
| INDUSTRIAL RADIO HOUSE | 2.15 |
| IZUMIYA | 2.74 |
| JETKING | 2.04 |
| KELTRON | 2.07, 2.17, 2.71 |
| LUXCO | 2.73 |
| MOTWANE | 2.11 |
| OSWAL ELECTRONICS CO. | 2.10 |
| PADMA ELECTRONICS | 2.16 |
| PATEL'S ANALOG | 2.16 |
| PRECIOUS KITS | 2.02 |
| SCIENTIFIC SALES | 2.04 |
| SCIENTIFIC MES TECHNIK | 2.15 |
| SWITCHCRAFT | 2.14 |
| VASAVI | 2.16 |
| VISHA | 2.75 |
| ZODIAC | 2.15 |

High Precision

High Reliability

Economically Priced

PCB Drafting Aids



• Tapes • Donuts • IC Patterns • Connectors • Targets • Alphabets • Component Legends.

Available as Stickers or Transfers.

Manufactured By:

IC IZUMIYA IC INC. JAPAN.

Sole Representatives For India:

ELEKTOR ELECTRONICS PVT LTD.



Ask For
Free Catalogue.

Cshotani Building, 52C, Proctor Road, Grant Road (East), Bombay-400 007. Phones : 367459, 369478.

COSMIC

COLOURVISION 5133

COLOUR TV

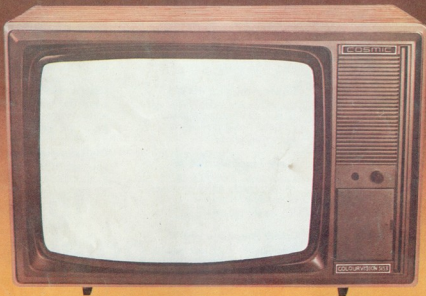

For over 30 years, with high technology and sophistication in the field of entertainment electronics, COSMIC in India has brought to the door step Audio and Video equipment of international quality.

COSMIC has earned consumer confidence with unparallel technology, and COSMIC now offers a COLOUR TV (51 cms.) which is almost beyond comparison, without compromising in the quality or technological advancement, but only in price.

COSMIC COLOUR TV stands up to any international standard. COSMIC with high intensity picture tube, gives sharp and rich contrast picture with fantastic visual definition.

COSMIC COLOUR TV with S.M.P.S. (Switch Mode Power Supply) is a shock proof set with built in regulated power supply (160 Volts to 260 Volts) that consumes less than 50 watts.

COSMIC COLOUR TV incorporates the HIGH GAIN TURRET TUNER to receive transmissions in fringe areas. VIDEO IN/AUDIO IN capability to connect any VCR, for better picture and sound quality. Also incorporates AUTO DEGAUSSING CIRCUIT.

International quality created for India by COSMIC