

elektor

up-to-date electronics for lab and leisure

AIR-MAIL COPY

D 71683

95

March 1983

75 p.

IR 112p. (incl. VAT)
\$ 2.50

Smid Smij

• opto-electronics:

automatic display brightness control,
new displays with a touch of nostalgia,
light-sensitive devices in theory and practice.

• versatile μ P memory:

64 K RAM or EPROM on a single board,
including battery back-up,
suitable for most 8-bit processors.

• also featuring:

part 2 of the Prelude preamplifier,
the ultimate reaction timer,
digital light meter,
servotester,
and more...



contents

fluorescent displays 3-18
 Fluorescent displays suffered from two main disadvantages: high operating voltage and price. Today, however, low-voltage types are available whose prices are competitive with those of LCDs. The main advantages of a fluorescent display compared to an LCD are the greater brightness and contrast; compared to an LED display, the fluorescent type requires considerably less power.

servo-tester 3-23
 (G. Lüber)

LCD luxmeter 3-24
 A new and up-to-date measuring instrument, convenient, compact and digital: the DLM. It is intended for accurate measurement of illumination, in two ranges: 0.1 ... 200 lux and 10 ... 20,000 lux. Its low current consumption of only 2 ... 4 mA makes the instrument independent of the mains and useful for portable applications.

universal memory card 3-28
 This memory card is suitable for most microcomputers with an 8-bit data bus and it can accept up to 64K RAM OR EPROM. A combination of both types of memory is also possible. If CMOS RAMs are utilised, a back-up battery will protect the memory contents for a considerable time, thus preventing the data from being lost when the computer is switched off.

Prelude part 2 3-36
 Prelude, the preamplifier in the Elektor XL range, is shaping up nicely! Literally, this month: all the modules, switches and controls are mounted on the bus board. This means that the final 'shape' is now defined.

technical answers 3-45
 Dynamic RAM card for ZX 81; Video text without a receiver; interference from microprocessors; polyphonic simplification; when is a buzzer not a buzzer?

automatic display dimmer 3-46
 The clarity and legibility of a light-emitting display is governed by its contrast with the background. There is a direct relationship between brightness of the background and ambient light, and so a desirable feature is for the brightness of the display to adapt itself automatically to ambient light so that the contrast remains the same. The OPL 100, a monolithic integrated display-dimmer, has been specially developed for this purpose.

reaction tester 3-50
 based on an idea submitted by L. van Boven

O, IC! 3-52
 Light-sensitive devices are used in all kinds of fascinating applications: light-meters, cybernetic models, movement sensors — even optical communication links. We don't really like printing 'theoretical' or 'educational' articles. In this case, however, some background information seems long overdue. Furthermore, we have two practical circuits to offer: a light gate and a distance meter.

audio traffic light 3-56
 What has a traffic light got to do with audio? Nothing, really, but this particular circuit drives three LEDs, in the colours red, orange (amber) and green. The LEDs indicate the level of the output signal from a preamplifier.

market 3-59

switchboard 3-61

EPS service 3-72

advertisers index 3-74

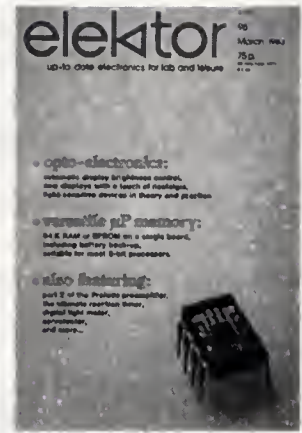

When you're so used to handling black ICs, with the odd grey one to relieve the monotony, seeing a chip embedded in clear plastic comes as a surprise. At first we thought it was just a commercial gimmick, but it turned out to be a real working device: the OPL 100, a light-sensitive display dimmer.

MARKETED BY

precious[®]

ELECTRONICS CORPORATION

HEAD OFFICE: 3, CHUNAM LANE, BOMBAY 400027
 PHONES: 369478/367459

BRANCH: B. ATHIPATTAN ST., MOUNT ROAD, MADRAS 600002
 PHONE 842716

Sumit

BBC Micro Computer

Please phone for availability

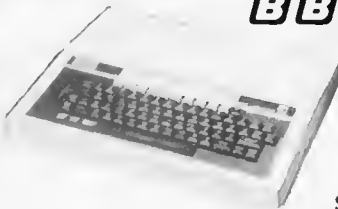

BBC Model B £ 399
(incl VAT Carr £ 8)

Model A to Model B Upgrade Kit £ 50
Fitting Charge £ 15
Partial Upgrades also available.

- SECOND PROCESSOR 6502 £ 170
- SECOND PROCESSOR Z80 £ 170
- TELETEXT ADAPTOR £ 196
- PRESTEL ADAPTOR £ 90

ACORN WORD
PROCESSOR 'VIEW' £ 52

All mating Connectors with Cables in stock. Full range of ACORN SOFTWARE, PROGRAM POWER & BUGBYTE SOFTWARE AVAILABLE

Phone or send for our BBC leaflet

BBC FLOPPY DISC DRIVES

FD Interface £ 95 Installation £ 20
Single Drive 5 1/4" 100 K £ 235 + £ 6 carr.
Dual drive 5 1/4" 800 K £ 799 + £ 8 carr.

BBC COMPATIBLE DRIVES

These are drives with TEAC FD50 mechanism and are complete with power supply
SINGLE: 100 K £ 190; 200 K £ 260;
400 K £ 340
DUAL : 200 K £ 360; 400 K £ 490;
800 K £ 610

OFFICIAL BBC DEALER

NEW LOW PRICES

NEC PC 8023BC

100CPS, 80 cols
Logic Seeking,
Bidirectional,
Forward and
Reverse Line Feed,
Proportional
Spacing, Auto
Underline, Hi-Res
and Block Graphics, Greek Char. Set.



Only £ 320
+ £ 8 carr

PRINTERS

SEIKOSHA GP 100A

80 cols 30 CPS Full
ASCII & Graphics
10" wide paper

Now only £ 175
+ £ 6 carr. Ask for
details on GP250A

EPSON MX 80 and 100F/T3

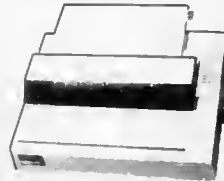

MX 80 80CPS 80 cols
MX 100 100CPS 136 cols

Logic Seeking,
Bi-directional, Bit Image
Printing, 9x9 Matrix
Auto Underline

MX 80 F/T3 £ 320
MX 100 F/T3 £ 430
(£ 8 Carr/Printer)

PRINTER ACCESSORIES

2,000 fan fold papers with
perforated margin . . .
£ 15 + £ 3.50 carr.

VARIETY OF PRINTER INTERFACES IN STOCK

RIBBONS FOR PRINTERS

GP 100A £ 6.50
EPSON MX80 £ 7.50
NEC PC8035 £ 7.50

AMPHENOL CONNECTORS

37 way Centronix Type £ 5.50
(IDC or Solder Type)
25 way IEEE Type £ 5.50

DRAGON 32K

*HI-LORes Graphics
*REAL TIME CLOCK
*COLOUR *SOUND
*PRINTER PORT
Only £ 173 + £ 4 carr.
Please phone to check avail-
ability Wide range of Software
in Stock.

MICRODOCTOR

This is not a logic
analyser or an oscillo-
scope. It tests a micro-
system and gives a
printed reprint on
RAM, ROM and I/O -
it will print memory
map, search for
code, check
dataline shorts
and operates
peripherals

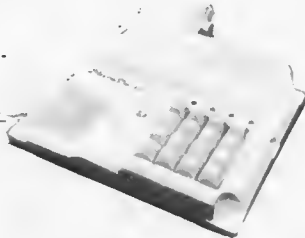

Microdoctor complete with PSU, printer, probe cable and two configuration board £ 295

SOFTY II INTELLIGENT PROGRAMMER

The complete micro processor development system for Engineers and Hobbyists. You can develop programs, debug, verify and commit to EPROMS or use in host computer by using softy as a romulator. Powerful editing facilities permit bytes, blocks of bytes changed, deleted or inserted and memory contents can be observed on ordinary TV.

Accepts most +5V EPROMS
Softy II complete with PSU, TV Lead and Romulator lead £ 169

RUGBY ATOMIC CLOCK

This Z80 micro controlled clock/calendar receives coded time data from NPL Rugby. The clock never needs to be reset. The facilities include 8 independent alarms and for each alarm there is a choice of melody or alternatively these can be used for electrical switching. A separate timer allows recording of up to 240 lep times without interrupting the count. Expansion facilities provided.

Complete Kit £ 120 + £ 2.00 carr.
Ready Built Unit £ 145 + £ 5.00 carr.
Reprint of ETI articles at £ 1.00 + s.a.e.

UV ERASERS

UV18 up to 6 Eproms £ 47.50
UV140 up to 14 Eproms £ 61.50
UV1T with Timer £ 60.00
UV141 with Timer £ 78.00
(Carr £ 2/eraser)

All erasers are fitted with mains switches and safety interlocks.

MICROTIMER (HOUSEKEEPER)

6502 Based Programmable clock timer with
* 224 switching times/week cycle
* 24 hour 7 day timer
* 4 independent switch outputs directly interfacing to thyristor/triacs
* 6 digit 7 seg. display to indicate real time, ON/OFF and Reset times
* Output to drive day of week switch and status LEDs.
Full details on request. Price for kit £ 57.00

ACORN ATOM

Basic Built £ 135
Expanded £ 175
(carr £ 3/unit)
Atom Disc Peck £ 299 + £ 6 carr
3 A 5 V Regulated PSU
£ 26 + £ 2 carr
Full Range of Atomsoft in stock.
Phone or send for our Atom list.

MONITORS

BMC 8M1401 14" Colour Monitor
RG8 Input 18MHz Bandwidth
£ 240 + £ 8 carr
HI RES 12" Green Monitor
Antiglare screen £ 99 + £ 6 carr
MICROVITEC 1431 M/S 14"
Colour monitor RGB input
£ 209 + £ 8 carr
RGB Lead for BMC £ 8
Composite Videolead £ 3.50

SEE OUR INSIDE FRONT COVER PAGE ADVERTISEMENT FOR COMPONENT PRICES

TECHNOMATIC LTD

MAIL ORDERS TO: 17 BURNLEY ROAD, LONDON NW10 1ED
SHOPS AT: 17 BURNLEY ROAD, LONDON NW10
(Tel: 01-452 1500, 01-450 6597, Telex: 922800)
305 EDGWARE ROAD, LONDON W2

PLEASE ADD 40p p&p & 15% VAT
(Export: no VAT, p&p at Cost)

Orders from Government Depts. & Colleges etc. welcome.

Detailed Price List on request.

Stock items are normally by return of post.



HOME LIGHTING KITS

These kits contain all necessary components and full instructions & are designed to replace a standard wall switch and control up to 200w. of lighting.

TDR300K Remota Control Dimmer **£14.30**

MK6 Transmitter for above **£4.20**

TD300K Touchdimmer **£7.00**

TOEK Extension kit for 2 way switching for TD300K **£2.00**

LD300K Rotary Controlled Dimmer **£3.50**



MINI KITS

MK1 TEMPERATURE CONTROLLER/THERMOSTAT
Uses LM3911 IC to sense temperature (80°C max.) and triac to switch heater 1KW **£4.00**

MK2 Solid State Relay
Ideal for switching motors, lights, heaters, etc. from logic. Opto-isolated with zero voltage switching. Supplied without triac **£2.60**

MK3 BAR/DOT DISPLAY
Displays an analogue voltage on a linear 10 element LED display as a bar or single dot. Ideal for thermometers, level indicators, etc. May be re-set to obtain 20 to 100 element displays. Requires 5-20V supply **£4.50**

MK4 PROPORTIONAL TEMPERATURE CONTROLLER
Based on the SL441 zero voltage switch, this kit may be wired to form a "burst fire" power controller, enabling the temperature of an enclosure to be maintained to within 0.5°C. Max. load 3KW **£5.55**

MK5 MAINS TIMER
Based on the ZN1034E Timer IC this kit will switch a mains load on (or off) for a preset time from 20 mins. to 35 hrs. Longer or shorter periods may be realised by minor component change. Max. load 1KW. **£4.50**

3-NOTE DOOR CHIME

Based on the SAB0600 IC the kit is supplied with all components, including loudspeaker, printed circuit board, a pre-drilled box (95 x 71 x 35mm) and full instructions. Requires only a PP3 9V battery and push-switch to complete. AN IDEAL PROJECT FOR BEGINNERS. Order as XK102 **£5.00**

XX113 MW RADIO KIT

Based on ZN414 IC, kit includes PCB, wound aerial and crystal earpiece and all components to make a sensitive miniature radio. Size: 5.5 x 2.7 x 2cms. Requires PP3 9V battery. IDEAL FOR BEGINNERS. **£5.00**

COMPONENT PACKS

- PACK 1 650 Resistors 47 ohm to 10 Mohm - 10 per value **£4.00**
- PACK 2 40 x 16V Electrolytic Capacitors 10µF to 1000µF - 5 per value **£3.25**
- PACK 3 50 Polyester Capacitors 0.01 to 1µF/250V - 5 per value **£3.55**
- PACK 4 45-Sub-miniature Presets 100 ohm to 1 Mohm - 5 per value **£2.30**
- PACK 5 30 Low Profile IC Sockets 8, 14 and 16 - pin - 10 of each **£2.40**
- PACK 6 25 Red LEDs (5mm dia.) **£1.25**

DVM/ULTRA SENSITIVE THERMOMETER KIT

This new design is based on the IC71726 (a lower power version of the IC17106 chip) and a 3 1/2 digit liquid crystal display. This kit will form the basis of a digital multimeter (only a few additional resistors and switches are required - details supplied), or a sensitive digital thermometer (-50°C to +150°C) reading to 0.1°C. The basic kit has a sensitivity of 200mV for a full scale reading, automatic polarity indication and a 2 litre low power requirement - giving a 2 year typical battery life from a standard 9V PP3 when used 8 hours a day, 7 days a week.

Price £15.50



DISCO LIGHTING KITS

DL1000K
This value for money kit features zero voltage switching, automatic level control and built in mic. No connections to speaker or amp required. No knobs to adjust - simply connect to mains supply and lamps (1KW channel) **Only £11.95**

DL2100K
A lower cost version of the above, featuring unidirectional channel selection with speed variable by means of a pre set pot! Outputs **Only £8.00**

Optional Opto input DLA1 **Only £2.00**
Allowing audio '1 beat' 1 - light response **60p**

DL3000K
This 3 channel sound to light kit features zero voltage switching, automatic level control and built in mic. No connections to speaker or amp required. No knobs to adjust - simply connect to mains supply and lamps (1KW channel) **Only £11.95**

HOME CONTROL CENTRE

This New Remote Control Kit enables you to control up to 18 different appliances anywhere in the house from the comfort of your armchair. The transmitter injects coded pulses into the mains wiring which are received by receiver modules connected to the same mains supply and used to switch on the appliance addressed. Receivers are addressed by means of a 16-way keyboard, followed by an on or off command. Since pushing buttons can become rather boring, the transmitter also includes a computer interface so you can programme your favourite micro to switch lights, heating, electric blanket, make your coffee in the morning, etc. without leaving your house. JUST THINK OF THE POSSIBILITIES. The KIT includes all PCBs and components for one transmitter and two receivers, plus a drilled box for the transmitter. **£42.00**

Additional Receivers XK111 **£10.00**

ELECTRONIC LOCK KIT XK101

This KIT contains a purpose designed lock IC, 10-way keyboard, PCBs and all components to construct a Digital Lock, requiring a 4-key sequence to open and providing over 5000 different combinations. The open sequence may be easily changed by means of a pre-wired plug. Size: 7 x 6 x 3 cms. Supply: 5V to 15 V d.c. at 40uA. Output: 750mA max. Hundreds of uses for doors and garages, car anti-theft device, electronic equipment, etc. Will drive most relays direct. Full instructions supplied. **ONLY £10.50**

Electric lock mechanism for use with latch locks and above kit **£13.50**

Have you got our **FREE ORANGE CATALOGUE** yet?

NO!! Send S.A.E. 6" x 9" TODAY!!

It's packed with details of all our **KITS** plus large range of **SEMICONDUCTORS** including CMOS, LS TTL, linear, microprocessors and memories, full range of LEDs, capacitors, resistors, hardware, relays, switches etc. We also stock **VERO** and **Antex** products as well as books from **Texas Instruments**, **Babani** and **Elektor**. **ALL AT VERY COMPETITIVE PRICES.**

ORDERING IS EVEN EASIER - JUST RING THE NUMBER YOU CAN'T FORGET FOR PRICES YOU CAN'T RESIST.

5-6-7-8-9-10

and give us your Access or Barclaycard No. **Answering** or write enclosing cheque or postal order. **service evngs** Official orders accepted from schools, etc. **& weekends**

LCD 3 1/2 DIGIT MULTIMETER

16 ranges including DC voltage (200 mv - 1000V) and AC voltage, DC current (200 mA 10A) and resistance (0.2 M) + NPN & PNP transistor gain and diode check. Input impedance 10M. Size 155 x 88 x 31mm. Requires PP3 9V battery. **£29.00**

Test leads included.



NOW ONLY £39
WITH SO MANY EXTRA FEATURES
OPTIONAL BLACK PLASTIC CASE.
READY DRILLED
£2.50

THE MULTI-PURPOSE TIMER HAS ARRIVED

Now you can run your central heating, lighting, hi-fi system and lots more with just one programmable timer. At your selection it is designed to control four mains outputs independently, switching on and off at pre-set times over a 7 day cycle, e.g. to control your central heating (including different switching times for weekends), just connect it to your system programme and set it and forget it—the clock will do the rest.

- FEATURES INCLUDE:-**
- 0.5" LED 12 hour display.
 - Day of week, amp/m and output status indicators.
 - 4 zero voltage switched mains outputs.
 - 50/60Hz mains operation.
 - Battery backup saves stored programmes and continues time keeping during power failure. (Battery not supplied).
 - Display blanking during power failure to conserve battery power.
 - 16 programme time sets.
 - Powerful "Everyday" function enabling output to switch every day but use only one time set.
 - Useful "sleep" function—turns on output for one hour.
 - Direct switch control enabling output to be turned on immediately or after a specified time interval.
 - 20 function keypad for programme entry.
 - Programme verification at the touch of a button.

(Kit includes all components, PCB, assembly and programming instructions). **ORDER AS CT5000**

For a detailed booklet on remote control — send us 30p and S.A.E. (6" x 9") today.

ALL PRICES EXCLUDE VAT

REMOTE CONTROL KITS

- MK6 SIMPLE INFRA RED TRANSMITTER**
Pulsed infra red source complete with hand-held plastic box. Requires a 9V battery **£4.20**
- MK7 INFRA RED RECEIVER**
Single channel, range approx. 20ft. Mains powered with a triac output to switch loads up to 500W at 240V ac. **£9.00** (RCS500K - Special Price for MK6 and MK7 together **£12.50**)
- MK8 CODED INFRA RED TRANSMITTER**
Based on the SL490, this kit includes all components to make a coded transmitter and only requires a 9V (PP3) battery and keyboard. 6 x 2 x 1.3cms **£5.90**
- MK10 16-WAY KEYBOARD**
For use with MK8 and MK18 to generate 16 different codes for decoding by the ML928 or MK1296 receiver (MK12) kit. **£5.40**
- MK11 10-Channel + 3 Analogue o/p Receiver**
Based on ML922 decoder IC. Functions include on standby output, toggle, control of volume, tone and lamp brightness. Includes its own mains supply **£12.00**
- MK12 16-CHANNEL IR RECEIVER**
For use with MK8 kit with 16 on/off outputs, which with further interface circuitry, such as relays or trans, will switch up to 16 items of equipment on or off remotely. Latched or momentary outputs - please specify when ordering. Includes its own mains supply. **£11.95**
- MK13 11-WAY KEYBOARD** For use with MK6, MK18 and MK11 kits. **£4.35**
- MK18 Mains Powered IR Transmitter**
Mains powered for continuous operation - single channel, for applications such as burglar alarms, automatic door openers, etc. Range approx. 6 ft. **£2.50**
- MK17 12V d.c. IR RECEIVER**
For use with MK6 or MK16. Relay output with DP 3 Amp change-over contacts, may be used as latched, momentary or "break beam" receiver. Operates from 6-13V d.c. **£9.50**
- MK16 HIGH POWER IR TRANSMITTER**
Similar to MK8 but with range of approx. 60ft. **£9.20**
- Auxiliary Kits - MK2 Solid State Relay**
Opto-isolated with zero voltage switching. No. triac supplied. **£2.60**
- MK16 QUALL LATCHED SOLID STATE RELAY**
Comprises 2 x solid state relays and latch for use with momentary version of the MK12. 2 output. (tracs required (not supplied). **£4.50**

24 HOUR CLOCK/APPLIANCE TIMER KIT

- Switches any appliance up to 11W on and off at present times once per day. Kit contains AY-5-1230 IC, 0.5" LED display, mains supply, display drivers, switches, LEDs, traces, PCBs and full instructions
- CT1000K Basic Kit **£14.40**
 - CT1000K with white box (56-121 x 71mm) **£17.40**
 - (Ready Built) **£22.50**

Add 56p postage & packing +15% VAT to total. Overseas Customers; Add £2.50 (Europe), £6.00 (elsewhere) for p&p. Send S.A.E. for further STOCK DETAILS. Goods by return subject to availability.

OPEN 9am to 5pm (Mon to Fri) 10am to 4pm (Sat)

FAST SERVICE - TOP QUALITY - LOW LOW PRICES

No circuit is complete without a call to -

ELECTRONICS EK
11 Boston Road
London W7 3SJ

ACCESS and BARCLAYCARD welcome

CLOCK TOWER

UXBIDGE ROAD

CAR PARK

BOSTON RD

HANWELL LT GARAGE

TEL: 01-567 8910 ORDERS 01-579 9794 ENQUIRIES 01-579 2842 TECHNICAL AFTER 3PM

Some of the **TELOMAN** PRODUCTS RANGE



TOOL PALLET FOR SPANNERS (PRICES ON APPLICATION)

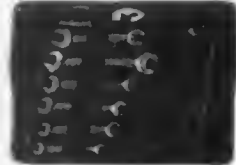

TOOLROLL £8.95 inc. VAT P&P £1.00
MEASURES 23"x13" WHEN OPEN. MADE FROM PVC. IT CAN HOLD UP TO 30 TOOLS AND HAS 3 POCKETS.

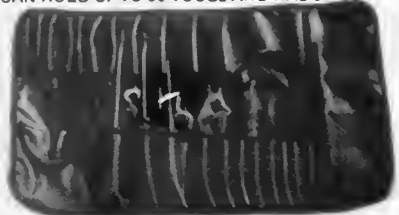

SALES PRESENTERS £7.48 inc. VAT P&P £1.50
IT CONTAINS 3 DOCUMENT POCKETS 4 RING BINDER BOARD CLIP WITH QUICK RELEASE. SIZE A4



SIZE TL100 19"x 14" x 6"



TL99 17"x 12" x 6" £39.90

THE TL100 HAS BEEN DESIGNED FOR THE PROFESSIONAL ELECTRONICS, TV OR INSTRUMENT TECHNICIAN WHO NEEDS TO CARRY A LARGE NUMBER OF SPECIALIST TOOLS. CONSTRUCTED FROM HARD WEARING ABS WITH STRONG ALUMINIUM FRAMES, TWIN HANDLES AND TOGGLE LOCKS. A MOULDED TRAY IN THE BASE, A COMPREHENSIVE 2 SIDED TOOL PALLET THAT IS REVERSIBLE WITH SPACE FOR OVER 40 TOOLS. THERE IS SPACE FOR DOCUMENTS AND A HEAT SINK FOR A HOT SOLDERING IRON TO PREVENT ANY DAMAGE BEING CAUSED.

ALSO AVAILABLE IS THE TL99 WHICH IS A SMALLER VERSION OF THE TL100.

TLW4 TOOLWALLET MEASURES 11"x14"x2½" WHEN CLOSED. MADE FROM REINFORCED PVC WITH A HEAVY DUTY INDUSTRIAL ZIP.

- * DISCOUNT STRUCTURE FOR MULTIPLE USERS ONLY
- * CUSTOM MADE TOOL PALLETS (ONLY FOR LONG RUNS)
- TOOLS WILL BE REQUIRED FOR MEASURING BUT WILL BE RETURNED.



Mail Order

Please send

Enclosed my cheque £

Name TL 100/TL99 P&P £2.60 extra!

Company

Address

ELK 3



Tools NOT included. British made.
Money back guarantee. Allow 7-21 days for delivery.



TLW4

Teleman Products Ltd
'Wychwood' 2 Abbots Ripton Rd, Sapley, Cambs, PE17 2LA
Tel: (0480) 65534

brighter
and easier
to read

Although fluorescent displays really pertain to the old generation of digital displays, new technologies and techniques have brought them to the fore once again. They have again become so popular that they compete with the liquid crystal displays. This trend will continue to grow with the introduction of the so-called, 'front fluorescent types'.

fluorescent displays



Figure 2. Various types of fluorescent displays are available today with a wide range of choice.

Figure 1. In principle, a fluorescent display works like an old-fashioned thermionic valve. An evacuated glass tube contains three electrodes (cathode, anode and grid). Electrons are released by the cathode through thermal emission, attracted by the positively charged grid and finally collide with the positively charged anode. The anode is coated with a fluorescent layer which lights up as a result of electron excitation.

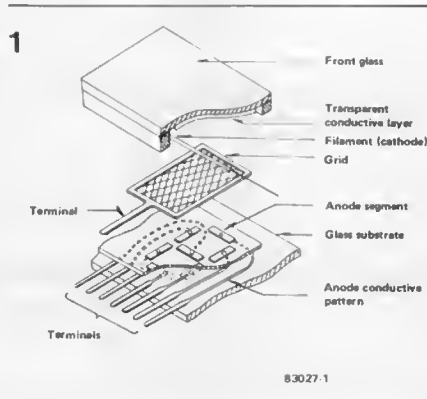

Fluorescent displays have not been used in many applications so far on account of their two main disadvantages: the high operating voltage and price. Today, however, low-voltage types are available whose prices are competitive with those of LCDs. The main advantages of a fluorescent display compared to an LCD are the greater brightness and contrast; compared to an LED display, the fluorescent type requires considerably less power. The different characters in a fluorescent display can be read very clearly, over a wide angle, thanks to the high contrast with respect to the background (see table 1).

Figure 1 shows the construction of a fluor-

escent display. There is a hard vacuum inside the glass envelope. The character segments are mounted on a substrate using thick film technology, and they are coated with a fluorescent layer. Each segment is electrically insulated from the others and each one forms an anode. As shown in figure 1, a grid and cathode are mounted above the anode segments. These both consist of very thin wires, so that they permit a clear view of the underlying anode segments.

The cathode consists of heat-resistant tungsten wire, coated with an oxide layer, and heated by the filament current. At a temperature of about 700°C the electrons contained in the oxide layer are released (thermal emission), and a current flows through the vacuum. At this temperature the cathode doesn't quite glow, and does not therefore appear as a disturbing band of light in the display.

A positive voltage (positive with respect to the cathode voltage) is applied to the grid and anode (segment). On account of the relatively high grid voltage, the electrons travel from the cathode to the grid with an ever increasing velocity, and only a few electrons are captured by the grid. Most of them pass through the grid and continue their journey toward the anode, where they collide with the fluorescent layer with which the anode is coated. The kinetic energy developed by the electrons on their journey from the cathode to the anode is converted to light energy in the fluorescent layer. In this way, each segment will light when a positive voltage is applied to the corresponding grid.

Situated on the inner side of the glass is a transparent conductive layer which is connected to the cathode, so that it is at cathode potential. This layer serves two purposes: First of all it ensures that the electrons emitted by the cathode travel in the right direction (not out through the glass!). Secondly, it increases the relatively small cathode surface so that the electron flow is uniformly distributed. This effect is enhanced by the fact that several of the cathode filaments are positioned above each segment. In this way the segments light up uniformly.

If there is no potential difference between cathode and grid, it is possible for some electrons to reach the fluorescent layer on the anode segments. For this reason, a voltage which is more negative than the cathode is applied to the grid. The electrons are then repelled by the grid instead of being attracted to it. The segments situated below that grid remain dark.

To darken a segment, a negative voltage is applied to the appropriate anode. With a positive grid voltage in this case, the negative anodes are not bombarded with electrons and remain dark.

To darken a character completely, a negative voltage is applied to the corresponding grid. Fluorescent displays are now available in widely differing forms: numbers, letters, symbols, scales (bars, dots, matrix) and combinations of these. Figure 2 shows some examples of fluorescent displays for particular applications.

3

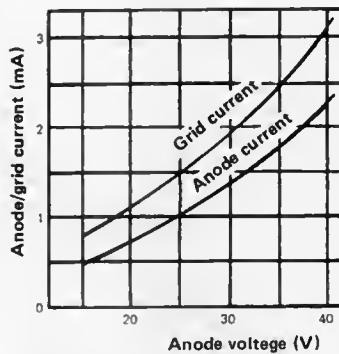

83027-3

fluorescent displays
elektor march 1983

Figure 3. The relationship between anode/grid voltage and anode/grid current is non-linear. This diagram also shows the relationship between anode and grid current.

4

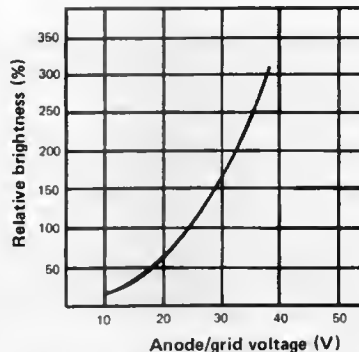

83027-4

Figure 4. The relationship between anode/grid voltage and relative brightness is also non-linear.

5

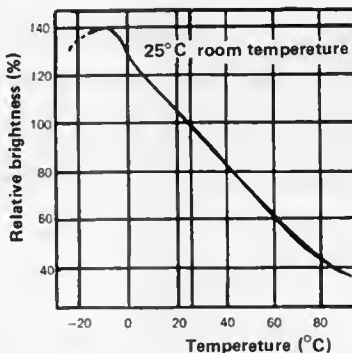

83027-5

Figure 5. The brightness of a fluorescent display is temperature-dependent, on account of the fact that the tube is not completely evacuated.

Brightness

The brightness of a segment depends on the kinetic energy of the electrons when they collide with the anode. This energy is converted to visible light in the fluorescent layer. The brightness can be increased by raising the anode and grid voltages. This results in an increase in electron velocity and more electrons per time interval reach the anode.

At a particular anode voltage the anode current is limited by the space charge. This

is the electron cloud which forms as a result of the emission between cathode and anode and which is very dense in the vicinity of the cathode. The electron cloud has a great negative charge (on account of the electrons), so that some of the electrons emitted by the cathode return there. A more intense electron cloud or space charge means that fewer electrons reach the anode from the cathode and the anode current decreases. There is no linear relationship between anode voltage and the anode current limitation imposed by the space charge. The electron cloud becomes more dense as the anode voltage rises. However, since the electron velocity increases in proportion to the square root of the anode voltage, the maximum anode current is:

$$I_a = kU_a\sqrt{U_a} = kU_a^{3/2}$$

k is a so-called geometric factor which takes into account the vacuum in the display and the arrangement and form of the electrodes (cathode, anode, grid).

Figure 3 shows the relationship between anode or grid current and anode voltage for a particular display. At an anode voltage of 25 V one can expect an anode current of 1 mA and a grid current of 1.5 mA. This characteristic curve also demonstrates that at an anode voltage of 25 V, the anode current is approximately 40% of the cathode current.

Above a certain value, the anode current ceases to rise even if the anode voltage is increased. This is the saturation point. At a particular cathode temperature, no more electrons (per time interval) can be emitted by the cathode. The saturation current depends on the following factors: the cathode coating, surface area and absolute temperature (in Kelvin).

The saturation does not imply however, that the brightness remains constant. As the anode voltage rises, the electron velocity increases. This means that the kinetic energy with which the electrons strike the anode

also increases. The brightness increases, although only to a slight extent. If the cathode is supplied with sufficient filament current, the saturation current is not reached. Figure 4 shows the relationship between anode or grid voltage and relative brightness. All the characteristic curves shown apply to the same display.

Temperature dependence

The brightness is temperature-dependent. This is due to the fact that air molecules remain in the tube in spite of the high vacuum. This can easily be demonstrated in an experiment. In a cold environment the so-called Brownian movement of the air molecules in the tube decreases. The electron flow encounters only slight resistance enroute to the anode. Thus the kinetic energy of the electrons is hardly 'decelerated' and the segments light up brighter. If the temperature drops too far however, the brightness decreases as the fluorescent layer becomes less sensitive. A rule of thumb is: above a temperature of 25°C (room temperature), the brightness decreases. In figure 5, the light output is plotted as a function of the temperature. At 40°C the brightness is approximately 80% of that at 25°C.

Contrast and colour

A display is easy to read when the contrast is high. The absolute brightness is not a decisive factor. With intense ambient light, the contrast can be considerably improved by placing a colour filter or neutral grey filter in front of the display. Widely differing colour filters can be utilised, because fluorescent displays exhibit a wide spectrum of light. Although the brightness decreases when a filter is placed in front of the display, the contrast increases and the display becomes easier to read. The choice of filter depends on personal taste and on the spectrum of the ambient light.

The first low-voltage types of fluorescent display contained a fluorescent substance that produced a fairly broad spectrum in

6

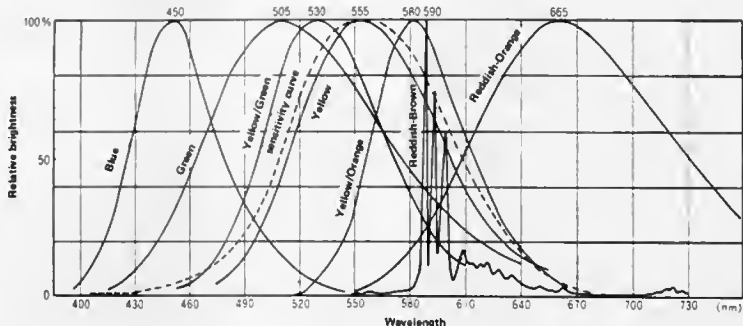

Figure 6. Different fluorescent coating substances result in different colours. The figure shows the frequency spectrum of some colours, and the dashed curve shows the spectral sensitivity of the eye.

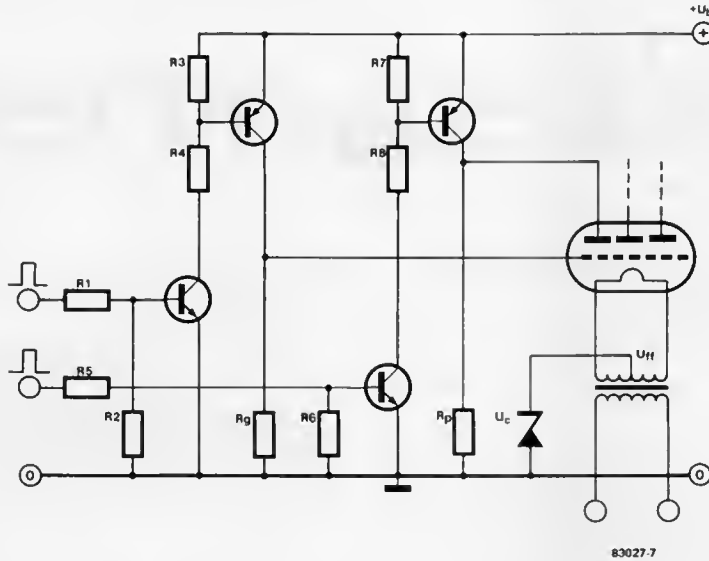

Figure 7. The basic drive circuit of a fluorescent display. Special ICs are available for this application.

the green. More recently, fluorescent substances have been developed which light up in a range of colours and displays are now readily available in various colours. Figure 6 shows the spectra of a number of colours and the dashed curve indicates the sensitivity of the eye.

Application

Figure 7 is the basic circuit for driving a fluorescent display. In this example, the characters are selected by CMOS or TTL level logic. The anode and grid voltages are switched via transistors. Fluorescent displays operate with anode and grid voltages of 12 to 47 V. Special ICs are available for multiplexing even complicated displays. To darken the segments or an entire character, a negative voltage (with respect to the cathode) must be applied to the anodes or grid. This is to prevent the electrons from the cathode from reaching the corresponding segments. For this reason a zener diode is used to apply a positive voltage (with respect to ground) to the cathode. The cathode voltage is approximately 2 to 8 V. An anode or grid that is not in use is pulled down to ground potential by means of resistor R_G or R_P , so that the voltage is negative with respect to the positive cathode. The cathode is heated with a filament voltage of 1 to 8 Vac, a d.c. voltage being unsuitable for this purpose since the voltage drop across the filament would result in different potential. This means that the cathode voltage would vary over the display area and the cathode current would have a non-uniform distribution. The segments would therefore light up with different degrees of brightness. This effect can be very

disturbing, particularly on displays with long filaments. If, however, the cathode filament is supplied with an a.c. voltage (at mains frequency), the eye is 'tricked' because the average brightness remains constant. This is not quite correct, because there is no linear relationship between cathode current and brightness. In practice however this is insignificant.

The cathode current in addition to the filament current also causes a very slight voltage drop across the filament. This effect can be diminished by applying the cathode current to both ends of the filament. The voltage drop caused by the cathode current is then halved in comparison to that with single-ended supply. This is achieved by connecting the cathode to the centre tap of the filament transformer (see figure 7). It should be noted that some display types can be heated with d.c.; in this case, the manufacturer's datasheet should be referred to.

Multiplexing is used with multidigit displays, each character being driven by the same decoder. The changeover from one character to the next takes place at a frequency high enough to make the switching operation imperceptible. With this method, sufficient brightness is achieved by matching the segment currents to the number of switched characters. For this purpose the manufacturer specifies the maximum peak current per segment. The advantage of multiplexing is obvious: instead of needing a separate decoder for each character, only one decoder is used for all characters; resulting in a considerable saving!

With multiplex drive, the response time of the fluorescent coating must also be taken into account. Both the rise and decay times

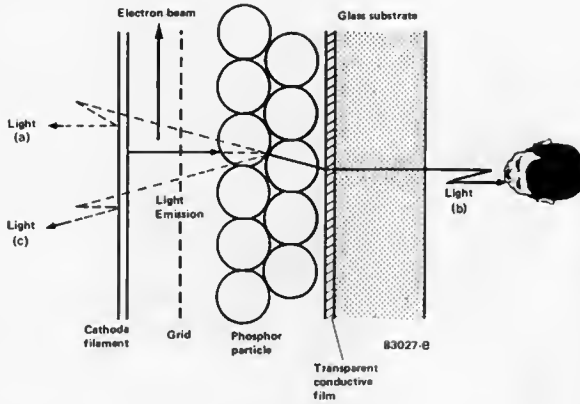

Figure 8. In the type known as e front fluorescent display, the element that was originally located at the rear (anode), is situated at the front. The anodes are transparent.

Table 1. Characteristics of major display devices

Item	Device	FFD (front-fluorescent)	FD (fluorescent)	LED	LCD	GGD (gas discharge)
Response Rate (μ s)		... 8	... 8	0.01	100,000	20 ... 1000
Driving Voltage (V)		10 ... 50	8 ... 50	1.6 ... 2.0	2 ... 10	170 ... 300
Power Consumption (mW/cm^2)		80	80	200	0.001	30 ... 100
Brightness (% of FD)		75	100	10	—	25
Operation Temp. ($^{\circ}C$)		-40 ... +85	-40 ... +85	-30 ... +80	-10 ... +80	-10 ... +70
Multicolour		yes	yes	yes	yes*	orange
Viewing Angle vertical/horizontal		150 $^{\circ}$ /150 $^{\circ}$	90 $^{\circ}$ /120 $^{\circ}$	150 $^{\circ}$ /150 $^{\circ}$	100 $^{\circ}$ /100 $^{\circ}$	120 $^{\circ}$ /120 $^{\circ}$
Life (hour) minimum		30,000	10,000	100,000	50,000	2500
Visual Recognition		excellent	good	acceptable	acceptable	acceptable

* by use of a filter

are approximately 8 μ s. The rise time for grid and anode voltages on the other hand, is only 0.5 μ s. The decay times of these voltages are controlled by external RC networks. With long decay times and high multiplex frequencies, an overlapping of the successive character information can take place. For this reason, the RC time constants should be kept low and, when darkening the characters, the appropriate segment drivers should be switched off. In this way the corresponding character extinguishes very rapidly.

The multiplex frequency selected for the display drive circuit must be such that the display does not flicker. Under no circumstances should the frequency be the same as that of the filament current or a multiple of the latter.

A new development: front fluorescent displays

Already during development of the first generation of fluorescent displays, methods were sought to apply the fluorescent coating directly to the inner side of the window – as is the case with television picture tubes. This results in an 'inverted' display with the anode being situated first in the line of vision.

The reason why this display principle has only been realised recently, is that certain technological obstacles had to be overcome. Its advantages compared to the 'older' types of display are: wider viewing angle is available and cathode and grid wires remain invisible.

Figure 8 shows the basic construction of a front anode type of fluorescent display. The anode consists of a transparent conductive layer, and when electrons collide with this layer at a low speed (corresponding to a low anode voltage), light is produced at the surface of the fluorescent substance. The thickness and quality of the fluorescent coating are critical parameters that affect the brightness of the display.

Another difficulty in manufacturing this type of display is that the anode leads must be positioned between the segments. With complicated structures, it may become necessary to interconnect leads in the drive circuit.

Table 1 is a brief survey of the different display types.

References:

Short form catalogue, 1983 edition, FUTUBA
'Front luminous vacuum fluorescent display',
November 1981 edition, FUTUBA

A problem frequently encountered in model construction is that of testing the functioning of a servo. The servo-tester described in this article provides the solution. It supplies an output frequency of 50 Hz; the pulse width can be adjusted between 1 ms and 2 ms and serves as an excellent test signal.

servo-tester

simple and inexpensive, but effective

One possible cause of failure in radio-controlled models is a malfunctioning servo. The problem is: how can this be checked when the model is being operated in the field? Certainly during contests, when you are forbidden to use the transmitter for testing. What we need is a battery-operated test circuit which supplies a PWM (pulse-width modulation) signal. The signal transmitted to the servo from the remote control receiver, has a pulse width of 1.5 ms for the neutral position of the servo, and the pulse widths for the two end positions are 1 ms and 2 ms respectively. Obviously, our servo-tester must generate the same signals.

The output pulse is positive, so that the circuit described so far is only suitable for servos which respond to a positive input pulse. For servos requiring a negative input pulse, some modifications must be made to the circuit. First the IC is replaced by a pin-compatible quad NAND gate 4011. Pin 6 of gate N1 (point A) must be connected to the positive supply and the lower end of R3 (point B) must be grounded. With so few components required, construction is a simple matter. Figure 2 shows a proposed layout. If the pulse-width is not quite correct, the value of C2 can be modified.

G. Luber

Figure 1. The servo-tester produces a PWM (pulse width modulation) output with positive output pulses whose width can be varied from 1 to 2 ms. The necessary circuit modifications for negative output pulses are described in the text.

1

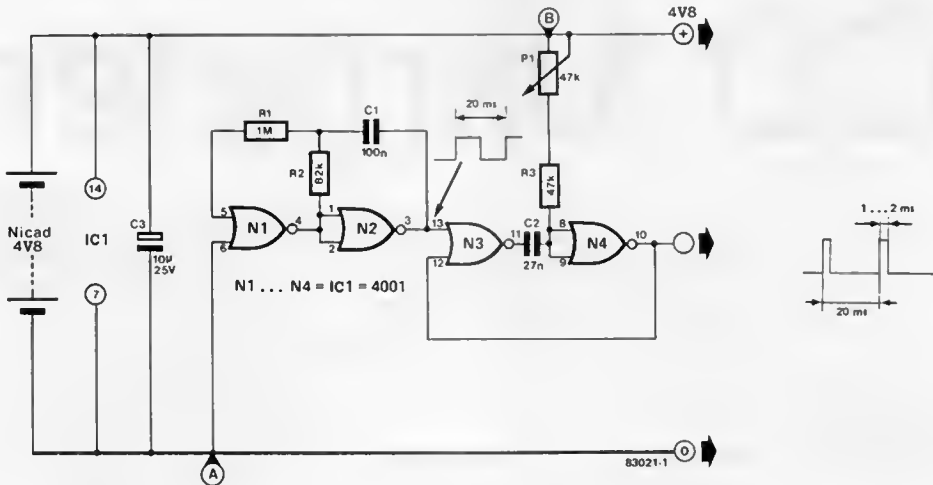
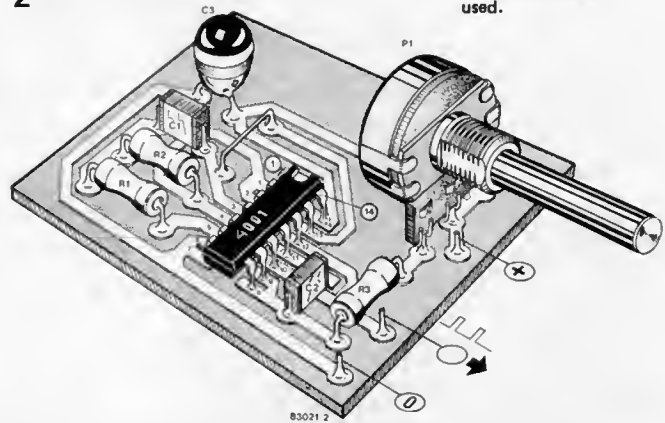
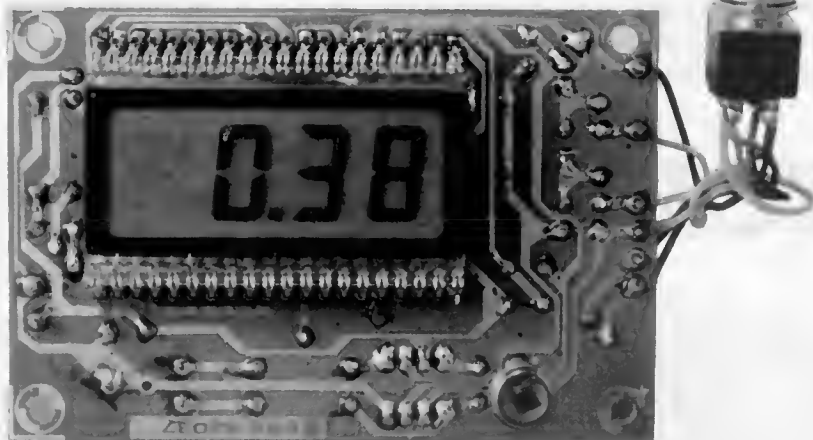

Figure 2. Construction is simple if this layout is used.

2



As shown in figure 1, the total component count is one IC, three resistors, one potentiometer and two capacitors: a NiCad 4.8 V battery is also needed to power the circuit. The IC is a 4001 CMOS type which contains four NOR gates. Gates N1/N2 are connected as an astable multivibrator which oscillates at a frequency of 50 Hz; the output pulse width is approximately 10 ms. The total period time is 20 ms, which is one of the requirements the servo-tester must meet. The next step is to make the output pulse of the tester adjustable from 1 ms to 2 ms. This task is performed by the monostable multivibrator N3/N4. Each positive-going edge from the astable multivibrator triggers the monostable; the latter, in turn, produces an output pulse that can be varied from 1 ms to 2 ms by means of P1.



illumination
indicated
digitally

This is a new and up-to-date measuring instrument; it is convenient, compact and digital: the DLM. The digital luxmeter is the latest member of our growing family of digital measuring instruments with simple construction, thanks to a high level of integration. It is intended for accurate measurement of illumination, in two ranges: 0.1 . . . 200 lux and 10 . . . 20,000 lux. Its low current consumption of only 2 . . . 4 mA makes the instrument independent of the mains and useful for portable applications.

LCD luxmeter

The luxmeter is suitable for many applications, especially those associated with photography and lighting. Particularly when arranging and designing lighting systems, proper lighting is important to prevent eyestrain. Poor lighting is false economy: illumination guide values do exist and should

be adhered to. Some of these guide values are listed in table 1, and the table also indicates the illumination levels of natural light sources. The illumination levels quoted in table 1 for artificial light sources are only average values.

The luxmeter presented here measures the amount of illumination. It consists of three units: the sensor and light-to-current converter; the analogue-digital converter with reference voltage source, counter, latch, BCD to 7-segment decoder and LCD driver; and finally, the liquid crystal display.

The sensor

A luxmeter is only useful if it 'sees' the illumination just like the human eye and for this reason the spectral sensitivities of the two sensors (eye and photodiode) should be as similar as possible. So far, no photosensitive device has been made available having exactly the same spectral sensitivity as the human eye. One which comes fairly close, however, is the BPW 21 photodiode. The dashed curve in figure 1 shows the relative sensitivity of the eye as a function of the wavelength of light. The solid curve represents the relative sensitivity of the BPW 21 photodiode and it can be seen that both the eye and the photodiode are relatively sensitive to visible light with a wavelength of approximately 555 nm. The radiation range of visible light is approxi-

Table 1. Illumination figures for natural light sources and guide values for artificial lighting.

Table 1	
Natural light	Illumination (lux = lx)
Clear night, full moon	0.3
Winter's day in December with overcast sky	900 . . . 2,000
Summer's day in June with overcast sky	4,000 . . . 20,000
Winter's day in December with clear sky	up to approx. 9,000
Summer's day in June with sunlight	up to approx. 100,000
Artificial lighting	
Candle light at 1 m distance	1
Side roads	4
Main roads	16
Staircases, railway platforms	30 . . . 60
Secondary rooms such as basement, hall, etc.	120
Living-rooms and offices	250
Classrooms, shops, work- shops	500
Drawing offices, precision engineering workshops	1,000

Table 2. Recommended values of light intensity with changing optical requirements.

Optical requirement	Example	Recommended light intensity lx
Orientation in closed rooms	Corridor lighting	100
Normal vision handling medium-sized objects	Living-room lighting; manufacture of cases for electronic equipment	400
Increased visual requirement, small details	Study of tech. literature; fitting components to a p.c.b.	800
Very great optical requirement, very tiny details	Detailed drawing-work; constructing a miniature device with high component density	1,500
Extremely great optical requirement, minute details	Repairing mechanical watches	3,000

Figure 1. Both sensors, the photodiode and the human eye, have almost the same sensitivity for the range of visible light with wavelengths from 400 nm to 700 nm.

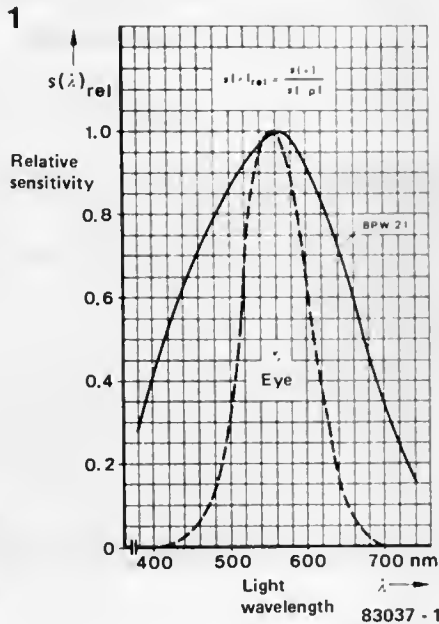

mately 400 – 700 nm and within this region the sensitivity varies considerably according to colour. This applies both to the eye and the photodiode. The curves in figure 1 also show that the sensitivity of the eye is relatively narrowband, whilst that of the photodiode is broad-band. The photodiode responds to violet light with a wavelength of 430 nm and to red light with a wavelength of 650 nm with greater sensitivity than the human eye. However, they both reach their maximum at a wavelength of 555 nm (yellow-green light). In other words, if a light source emits red light and yellow-green light with the same radiation intensity, the yellow-green light appears considerably brighter to both the eye and the photodiode. The two curves in figure 1 do not exactly coincide but are fairly close to each other and the colour correction filter in the photodiode is used to obtain compatibility. For both sensors, no perception is possible outside this radiation range. Radiation under 400 nm is in the ultraviolet region and that over 700 nm is in the infrared region.

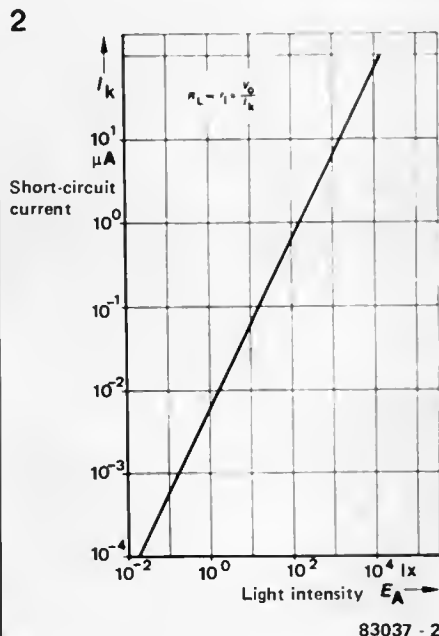

Figure 2. The short-circuit current for the BPW 21 photodiode is linear over a wide range.

Another favourable characteristic of the BPW 21 photodiode is its excellent linearity as shown in figure 2. The short-circuit-current I_k is perfectly linear over an illumination range from 0.01 lx to 10,000 lx. In the region of interest, this results in good linearity as regards the absolute sensitivity which is typically 7 nA/lx, (4,5 nA/lx min., 10 nA/lx max.) and a linear scale readout.

The circuit

Circuit operation is straightforward: light is converted to current which is then used to produce a directly proportional voltage followed by a digital readout. There we have a brief description of the circuit shown in figure 3; it does however warrant a more detailed description.

Photodiode D1 is connected in 'current source' mode so that the linear portion of its characteristic curve is used where current is directly proportional to light intensity over a wide range, in the region of several decades. A virtual short circuit is obtained relative to the diode, which bridges the inverting and non-inverting inputs of IC1. This improves linearity and eliminates the otherwise negative influence of the photo-

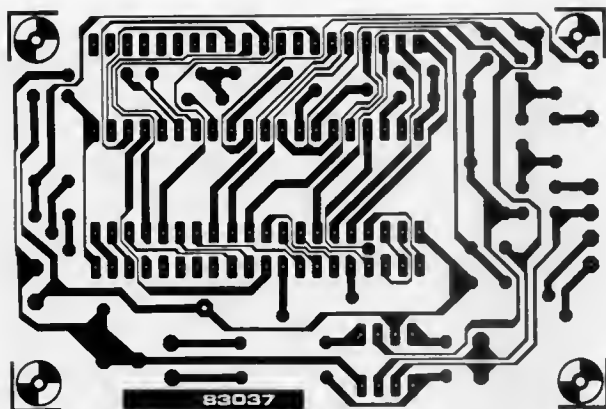

Parts list

Resistors:

R1, R5 = 100 k
 R2, R10 = 1 k
 R3, R4 = 22 k
 R6 = 47 k
 R7 = 4M7
 R8, R11 = 1 M
 R9 = 27 k
 P1 = 50 k (47 k) preset
 P2 = 100 k
 P3 = 1 k 10-turn presets

Capacitors:

C1 = 56 p
 C2 = 220 p
 C3 = 10 μ /10 V
 C4, C6 = 100 p
 C5 = 470 n
 C8 = 220 n

Semiconductors:

T1 = BC549C
 D1 = BPW21
 IC1 = CA3130
 IC2 = 7106
 LCD: 3 $\frac{1}{2}$ digit, digit
 height 13 mm

For example:

Hamlin 3901 or 3902;
 LXD 43D5R03;
 Hitachi LS007C-C,
 H1331C-C

Miscellaneous:

S1 = single-pole on/off
 switch
 S2 = double-pole change-
 over switch
 Battery clip for 9 V
 battery.

BPW 21 photodiode directly to the copper track side of the p.c.b. Ensure that it is correctly connected! The LCD display should also be fitted to this side of the p.c.b. If pin 1 is not marked on the display, the decimal points can be used for orientation. They are visible when the display is viewed at an angle. The display is correctly positioned on the p.c.b. when the decimal points are on the same side as the light sensor. All other components are fitted to the component side.

Calibration and alignment

A 40 W and 100 W bulb are required for calibration; they are inserted in sequence into a reflectorless socket with no other light source switched on. No mirrors or reflecting surfaces should be in the vicinity, and brightly coloured walls or ceilings should also be avoided before commencing to calibrate.

- The offset alignment is done *before* mounting the photodiode D1(!). Set the display to 000 with P1. In exceptional cases it may prove necessary to modify the values for R3, R4 and P1 (R3 = R4 = 10 k and P1 = 100 k).
- Mount the photodiode, set switch S2 to the 20,000 lx range and position the luxmeter 30 cm from the bulb (100 W). Make sure that the bulb is directly above the sensor. Now adjust preset potentiometer P3 to obtain a reading of 1.00 (klx) on the display (i.e. 1,000 lux).
- Change to the 40 W bulb and increase the distance to 50 cm, then select the 200 lx range. Adjust P2 to obtain a reading of 150.0 (lx)

The luxmeter is now ready for use and we suggest checking the illumination levels quoted in Table 1.

Figure 4. Printed circuit board and component layout for the luxmeter. The liquid crystal display and the photodiode are situated on the copper track side, resulting in a compact design.

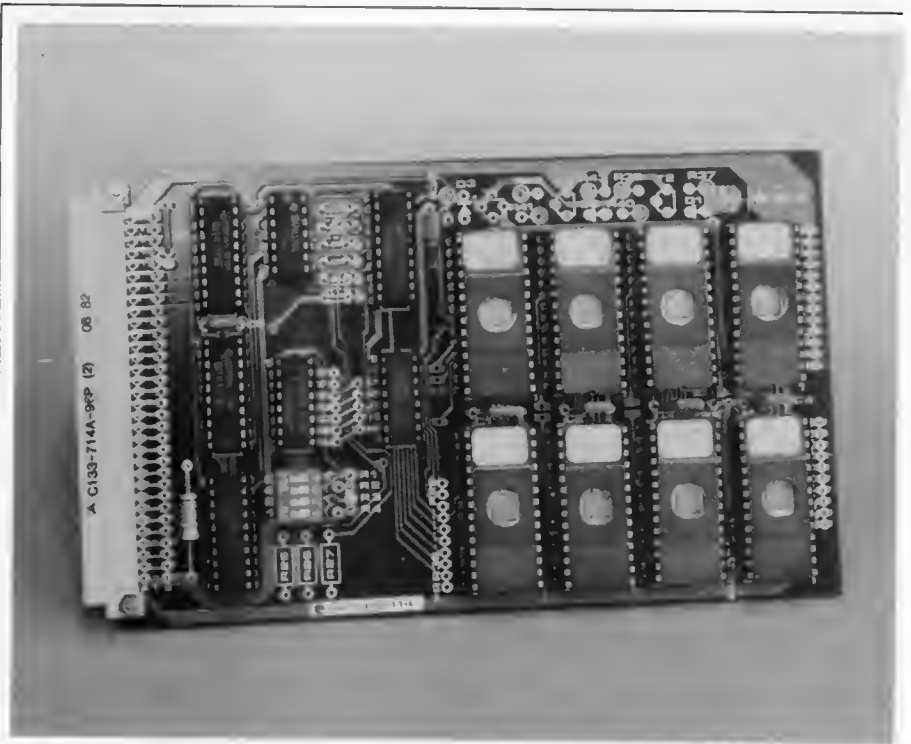

The continuing development of 'bigger' memory ICs obliges us to develop new, versatile and more powerful RAM/EPROM cards at regular intervals. The universal memory card described here is suitable for most microcomputers with an 8-bit data bus and it can accept up to 64 K RAM or EPROM. A combination of both types of memory is also possible. If CMOS RAMs are utilised, a backup battery will protect the memory contents for a considerable time, thus preventing the data from being lost when the computer is switched off (power-down).

universal memory card

64 K RAM
and/or
EPROM with
battery
backup

The computer memory

In general, a microcomputer system contains the sections shown in figure 1. The microprocessor chip contains various registers, the program counter and the arithmetic and logic unit (ALU); the clock generator may also be included on-chip in certain microprocessor types. The other main section is the memory, usually consisting of both RAM and ROM or (E)PROM. The data to be processed are stored in the RAM and called as required; the EPROM contains 'permanent' operating instructions for the microprocessor. In most cases the so-called operating program (monitor) for the microcomputer is resident in this section of memory.

Addresses, data and control signals processed and output by the computer are transferred via the address bus, data bus and control signal bus. It would be beyond the scope of this article to consider the many details that must be taken into account when utilising

the basic system of figure 1 with a particular microprocessor. Instead, we shall take a closer look at the data memory and program memory block.

Those readers who have worked with the Elektor SC/MP system or Junior Computer from the start know how quickly the maximum memory capacity of a basic system is reached. No wonder we had to meet the demand for bigger memories by developing 4 K RAM, 8 K RAM/EPROM and 16 K 'dynamic' RAM cards. This progress was possible because the need for greater memories was also experienced commercially, stimulating manufacturers to develop and produce 'bigger' ICs.

Dedicated systems as opposed to development systems

A development system can also be used for 'dedicated' applications, but the reverse is

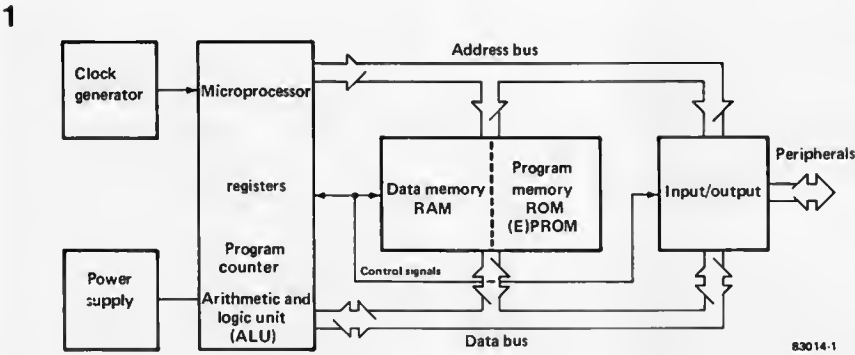

Figure 1. In general, a microcomputer system consists of the microprocessor and two distinct types of memory. The data to be processed are stored in the (RAM) data memory and called as required. The program memory contains the operating program (monitor) for the microcomputer. This is stored in ROM or (E)PROM.

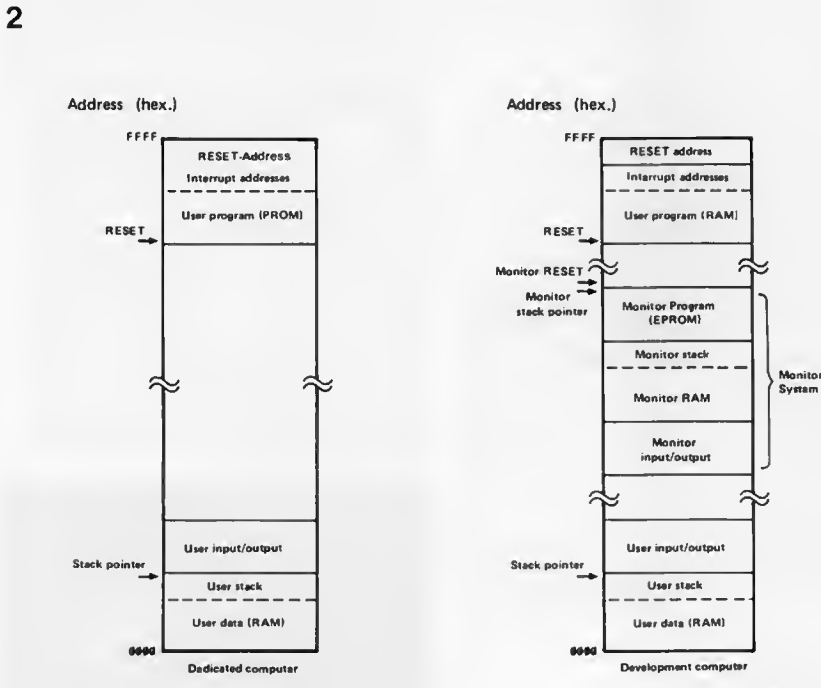

Figure 2. Development computers, such as the Junior or SC/MP, use RAMs in the program memory area. A large part of the addressable memory area is occupied by the monitor program, in ROM or (E)PROM, with its associated 'monitor RAM' area. Dedicated computers such as Intelekt, the 6502 housekeeper and the darkroom computer are more common. Their program memories consist of an (E)PROM. The large monitor memory is not required.

not true. The difference between a dedicated system and a development system is shown in figure 2. The computers that tend to run out of memory space are the development systems (SC/MP, Junior and so on). Their data and program memories are typically organised as in figure 2. RAMs are used in the program memory area. The monitor program occupies a large part of the addressable memory area. It consists of a ROM or (E)PROM containing the operating instructions, a RAM area for intermediate storage and a memory-mapped input/output block. The monitor program itself contains various routines that are needed for developing other programs, such as: input/output routines, memory scan and memory input. Elektor has published several 'dedicated computers', such as Intelekt, the 6502 housekeeper and the darkroom computer. Their program memories consist of an EPROM. A monitor is not required, thus obviating the

need for the large monitor memory. But, to get back to the development computer: a 16-bit address bus can define and call a total of $2^{16} = 65536 = 64 \text{ K}$ addresses. (The location of an address is normally expressed in hexadecimal: thus an address range of 0000_{hex} to $FFFF_{\text{hex}}$ covers 64 K.) Given this fact, it would seem logical to provide a microcomputer system with a 64 K memory from the outset. However, this is the exception rather than the rule - mainly because that type of memory was too bulky and expensive until quite recently!

Memory development at Elektor

Figure 3 shows the development of Elektor memory cards. In March 1978, when the memory card for the SC/MP system was introduced, only MOS ICs with an organisation of 256×4 bits were available. This meant that 32 ICs were needed for a 4 K

Figure 3. The development of Elektor RAM and/or EPROM memory cards. From 4 K RAM in 1978 to 64 K in 1983 and from 16 K EPROM in 1980 to 64 K in 1983, with the same space requirement in each case. Although not shown, 2716 2 K EPROMs can also be mounted on the universal memory card. The types indicated stand for the device type: '2716' means 'a 2 K x 8 EPROM', say, and '6116' means 'a 2 K x 8 RAM'.

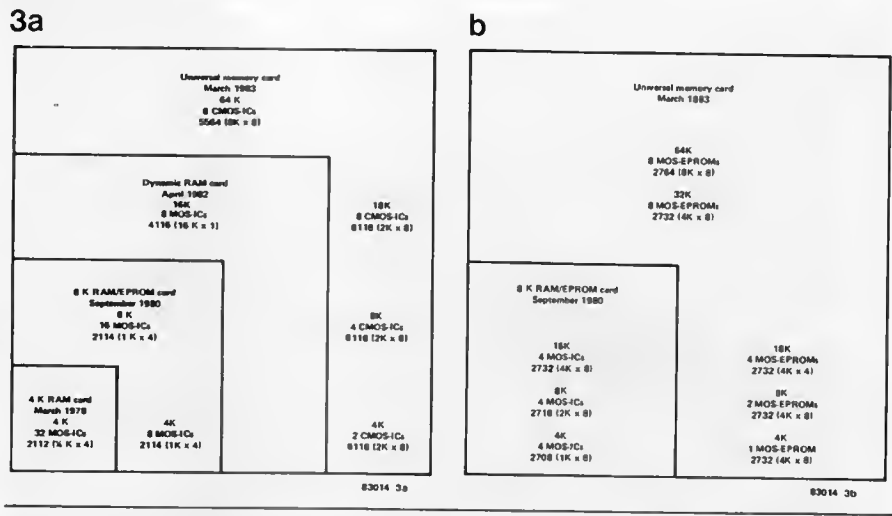

memory. Nowadays the same memory capacity can be achieved with only two 6116 CMOS ICs. In the near future, 8 K x 8 CMOS RAMs will be available – making it possible to store 65536 bytes on a single 'universal memory card'!

PROMs and EPROMs reached this stage of development some time ago, and 65536 bytes can also be stored in eight MOS EPROMs on the universal memory card. (In fact, even 32 K x 8 CMOS PROMs are now available. Only two of these ICs would therefore be needed in order to store the total 62 K! However, these ICs are not suitable for the universal memory card.)

For the computer hobbyist the development of 'bigger' memory ICs means that a single Eurocard will now provide as much memory as 16 cards did 4 years ago. Over the same period, the cost of memories has dropped considerably: 4 K of RAM cost about 80 pounds then, but now (using 6116's) the same storage area costs less than 10 pounds!

The universal memory card

Figure 4 is the circuit diagram of the universal memory card. 2 K (2716), 4 K (2732) or 8 K (2764) EPROMs and 2 K (6116) or 8 K (5564) CMOS RAMs can be used. The type numbers in parentheses stand for all memory ICs with the same organisation and same pin assignments.

Two versions of this memory card can be built: with or without battery backup (CMOS version or MOS version respectively). In the former case the power supply for the CMOS RAMs is backed up with two miniature cells so that the data are not lost when the computer is switched off. Mixed operation (CMOS and MOS ICs) is not possible, nor would it serve any useful purpose. The battery would be quickly discharged and T1 would not be capable of supplying the necessary current.

In the CMOS version, the circuit draws approximately 200 mA in operation. Only one RAM is accessed at a time and this draws approximately 35 mA. However, the rest of the circuit requires about 165 mA. The average operation current for a RAM is less than

35 mA. The figure depends on the number of times the RAM is accessed in a given period. The quiescent current of the RAM ($\overline{CE} = 1$) is only a few μA . One more important point: the CMOS version requires pull-down resistors, open-collector ICs and the circuit associated with T1 . . . T3. When the supply voltage is switched off (power-down) inputs \overline{CE} or \overline{OE} and \overline{WE} of the RAMs must be inhibited (logic 1). Open-collector ICs with pull-up resistors to the battery supply rail are used for this reason: the inputs will automatically go to logic 1 and inhibit the RAMs. Pull-down resistors are also required for (some) CMOS RAMs. The reason is illustrated in photograph 1. The upper trace is

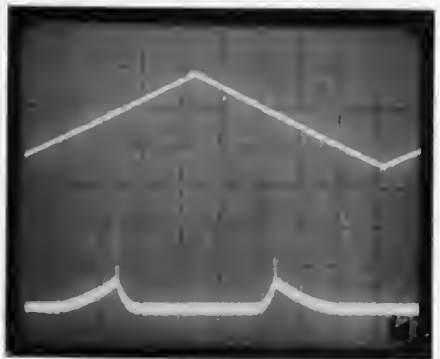

the voltage on one of the address lines of a Hitachi 6116 CMOS RAM, and shown below it is the current drawn by this IC. There are no pull-up or pull-down resistors. At approximately half the operating voltage (one half of 2.4 V in this case), the current rises considerably (up to approximately 200 μA). The same effect occurs at each of the 11 address lines, so that the total current can be 2.2 mA instead of 'typically 2 μA ', as specified in the datasheet for the HM 6116 LP. To avoid this problem, pull-down resistors are essential: a current which is greater than expected by a factor of 1000 will quickly discharge the battery!

This heavy current consumption occurs when a floating address input causes both CMOS transistors conduct. This is not always the case, nor does it apply to all

inputs. The 6116, for example, doesn't need pull-down resistors for the data lines. With ICs from other manufacturers, the situation may be different. The best solution is to play it safe, and mount all resistors shown. They cannot do any harm, and there is room for them on the printed circuit board. The MOS version has a higher quiescent current consumption. MOS devices can be used for all the RAMs and EPROMs; the advantage is that these ICs cost only half as much as the CMOS devices. The disadvantage is that each 2716 EPROM, for example, draws a quiescent current of about 35 mA. Multiplied by 8: nearly 300 mA. Add about 165 mA for the rest of the circuit: a total quiescent current of 450 mA! The MOS version does not need open-collector ICs, and all the resistors are omitted except for R1...R4. The circuit associated with T1...T3 is not required, and wire links are

inserted in place of the collector-emitter paths of the transistors T1 and T2. The address and data lines are fully buffered except for A16 and A17. However, A16 and A17 are rarely utilised. The card need not have a full complement of ICs, of course: it will also operate perfectly with only one EPROM or RAM.

Address decoding

The address decoding is unusual. The addresses are summed in two's complement. This corresponds to a subtraction, as shown in the example (next page). If the address selected on the board corresponds to the incoming address, the result is zero. The actual address decoder IC5 is then enabled via N9 and generates the CE signal that selects the appropriate RAM or EPROM.

Figure 4. Two versions in one circuit diagram. The MOS version is less expensive and less involved. It merely contains resistors R1...R4, capacitors C1...C7, IC1...IC7 and IC8...IC15, as required (from 1 to 8 devices). With the CMOS version a permanent memory can be created whose data will not be lost. Nickel cadmium rechargeable cells or disposable batteries are used to provide backup when the operating voltage is switched off. A power-down circuit with T1...T3 is also provided.

4

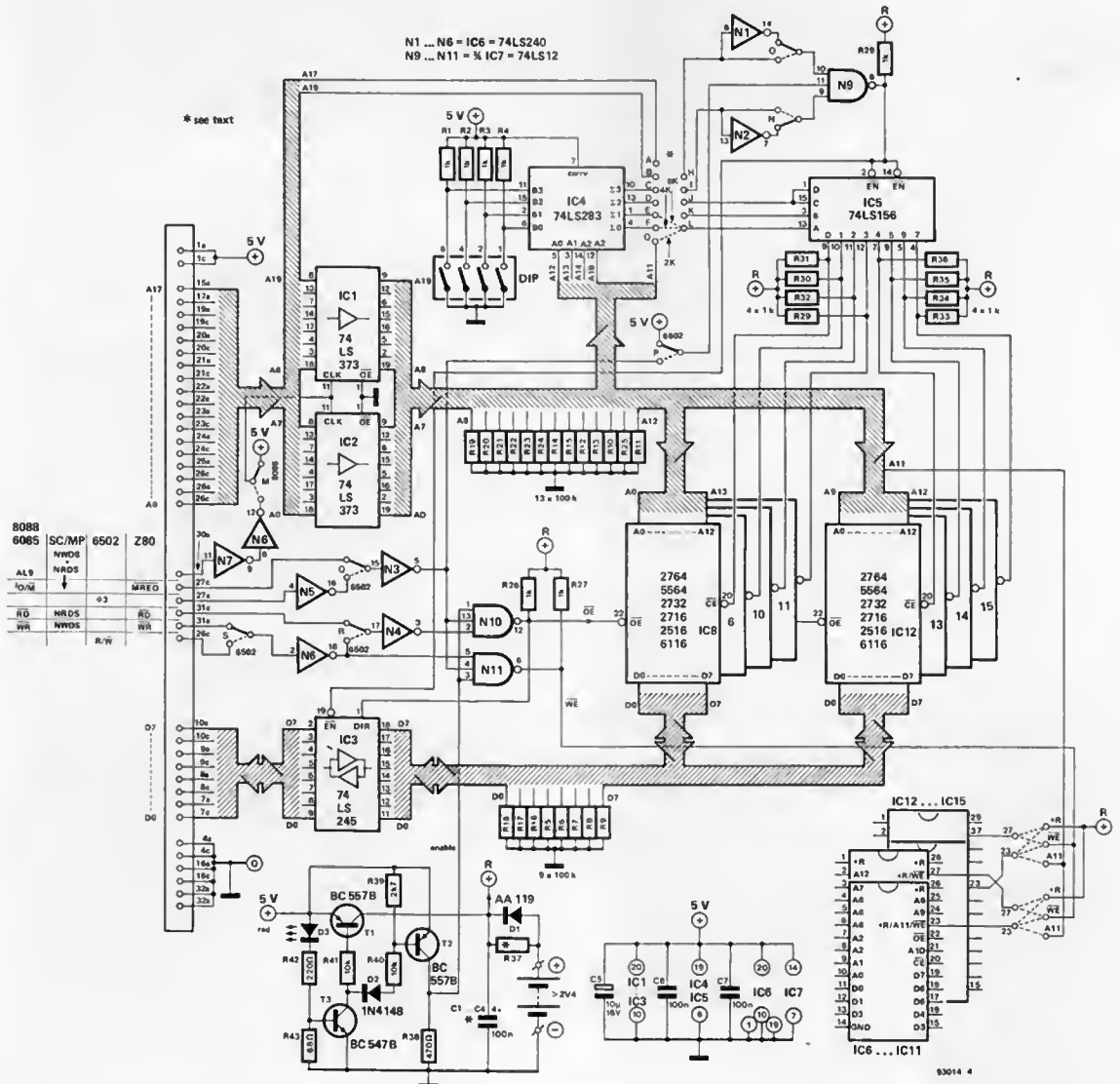

As an example, assume that the address 8000_{hex} is selected with the DIP switches. In accordance with the two's complement method, only switch 'A15' is closed (see \bar{B} in the calculation). The two's complement is obtained by adding 1 to the carry input of IC4 (pin 7). Now, if 1000 is also available at the A-inputs of IC4 (for the 8000 address block), the information 0000 appears at the outputs. Let us assume that the wire links for 2 K RAMs or EPROMs are inserted; then IC5 sees 000 at its A, B and C-inputs ('A11' is also 0 for this address block). The activating signal, logic zero, is also present at the enable inputs (pin 2 and pin 14), via N9. Thus the address decoder is switched on and provides a \bar{CE} signal for IC8 at output 0. This RAM or EPROM is enabled. Next, let us assume that address 8800 appears. There is a logic 1 on address line A11 but the output from IC4 is still 0000 . The address decoder switches to the next 2 K RAM or EPROM. Readers who feel like trying their hand at binary and hexadecimal calculations can work out other examples and create a memory chart for all possible settings of the DIP switches and wire links A...L. The example shows that 2, 4 and 8 K ICs cannot be mixed easily.

If the memory area is organised in 8 K blocks, the card will respond to all possible 64 K addresses (even if ICs are not mounted in all positions). If, for example, the address 8000 is selected, the memory is scanned from 8000 to $FFFF$, and then from $(1)0000$ to $(1)7FFF$! If the monitor is located somewhere in this area, something is bound to go wrong. There is a way of avoiding this, however: memory areas can be blocked with address lines A16 and A17 as required. The way in which this is done must be worked out in each case. Once again, the calculation example should be consulted. Wire links '0' and 'N' at N1 and N2 can be used to select 'active low' or 'active high' control. A logic 0 must be present at the output of N9 (i.e. a logic 1 at all inputs) for IC5 to be activated.

Example of calculation with two's complement:

$$\begin{array}{r} B = 1000 = 8_{hex} \\ \bar{B} = 0111 \\ +1 \quad 1 \quad \text{two's} \\ \hline 1000 \quad \text{complement} \\ A = 1000 \\ \hline (1) 0000 \end{array}$$

Control signals

The control signals provided by the different types of processors are listed in the table in figure 4, next to terminals 27, 31 and 29. The 8085 processor cannot be connected without modifications, since the data and addresses must be de-multiplexed before they are applied to the memory card. The data bus buffer outputs data when the \bar{RD}

5

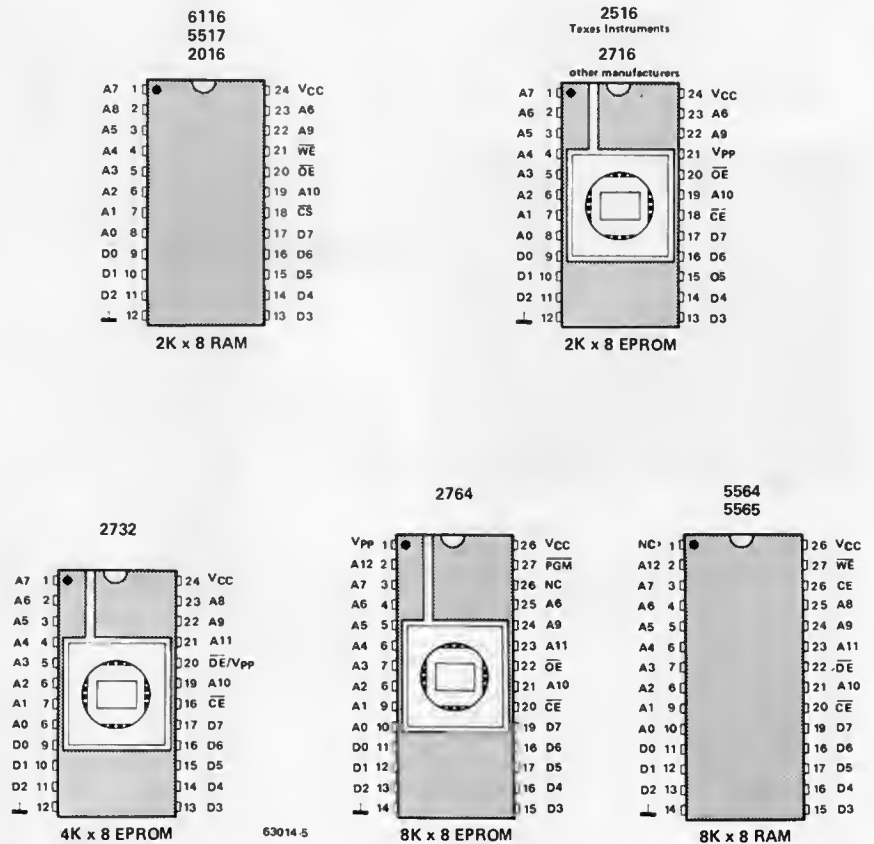
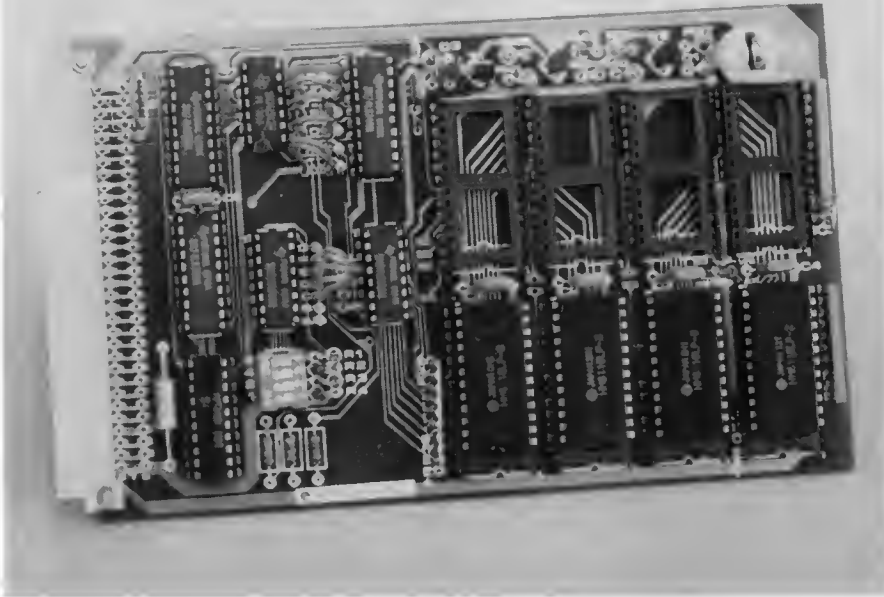

Figure 5. These are the RAM and EPROM types that can be used. The designations stand for memory ICs with the same function, organisation and pin assignments. Other information, particularly concerning equivalent types, can be found on info cards 75...79. The Texas Instruments EPROMs 2532 and 2564 can only be used in conjunction with an adapter socket. Although the various CMOS RAMs have the same pin assignments, the quiescent current consumption depends on the type.



signal is present.

The memory card can also be used with a ZX 81. A0 ... A14 and D0 ... D7 are connected to the computer in order to create a 16 K memory. The control signals are applied as for the Z80. The address is set to 4000_{hex} with the DIP switches (only close '4'). One more problem must be solved: the internal RAM in the ZX81 operates in parallel with the memory card. The solution is to connect the RAMCS output (pin 2A) of the ZX81 to +5 V. Furthermore, the ZX81 does strange things with its A15 output, so this input to the memory card should be connected to supply common instead.

The 2650 processor can also be connected (TV games computer!). 6502 operation is selected: OPREQ/2650 at $\Phi 2/6502$; invert $\bar{R}/W/2650$ and apply to $R/\bar{W}/6502$. In the TV games computer, the necessary R/\bar{W} signal is already present at point 17. Also connect the address and data lines. Line $M/\bar{I/O}$ remains unused, but this is no real disadvantage, because IO is rarely used. For the odd exception, $M/\bar{I/O}$ and OPREQ must be combined externally.

If the card is used in conjunction with the SC/MP system, bus line 27a must not be overlooked; the *input* of the SC/MP oscillator is connected here. With N5 connected, the oscillator may stop. The remedy is to cut this track (it has not been used so far) or to select the other connection point for the oscillator on the SC/MP CPU board.

Power-down and battery backup

The power-down circuit consists of transistors T1 ... T3. It is used in conjunction with CMOS RAMs, and explained earlier. The operating voltage 'R' is present before the enable signal, because T1 is switched on before T2 (power-up). T3 serves as a switch

and D3 lights up when the operating voltage is present. The enable signal inhibits reading and writing via N10 and N11.

The battery backup itself can consist of either disposable or rechargeable batteries. If the former are utilised, R37 *must* be omitted. For rechargeable batteries the value of the charging resistor can be calculated according to the rule of thumb: R37 is equal to 2.5 V divided by one twentieth of the battery capacity.

RAMs and EPROMs

The parts lists for the CMOS or MOS versions of the memory card obviously do not include all possible memory devices, but the types specified are a general designation for ICs with the same function, organisation and, hopefully, the same pinning. The pin assignments for EPROMs and RAMs are given in figure 5. Other information, particularly on equivalent types, can be found on the *info cards* 75 ... 79. One important point to note is that the Texas Instruments EPROMs 2532 and 2564 can only be used if their pin assignments are matched to the equivalent memory ICs by means of an adapter socket.

The RAM and EPROM types to be used are matched to the memory card according to 'size' and function, using the wire links at pins 23 and 27. This match applies to four ICs simultaneously (IC8 ... IC11 and IC12 ... IC15)! A further subdivision is only possible if the corresponding tracks are cut and the pins wired separately.

Timing

Some problems may occur with the timing when connecting the memory card to different processors. The adjacent table shows which RAMs and EPROMs can be

		6502		Z80	
		1 MHz	2 MHz	2 MHz	4 MHz
450ns	EPROM				
	RAM				
250ns	EPROM				
	RAM				
		350ns, or faster			
450ns	EPROM				
	RAM				
250ns	EPROM				
	RAM				
		faster than			
350ns	EPROM				
	RAM				
250ns	EPROM				
	RAM				

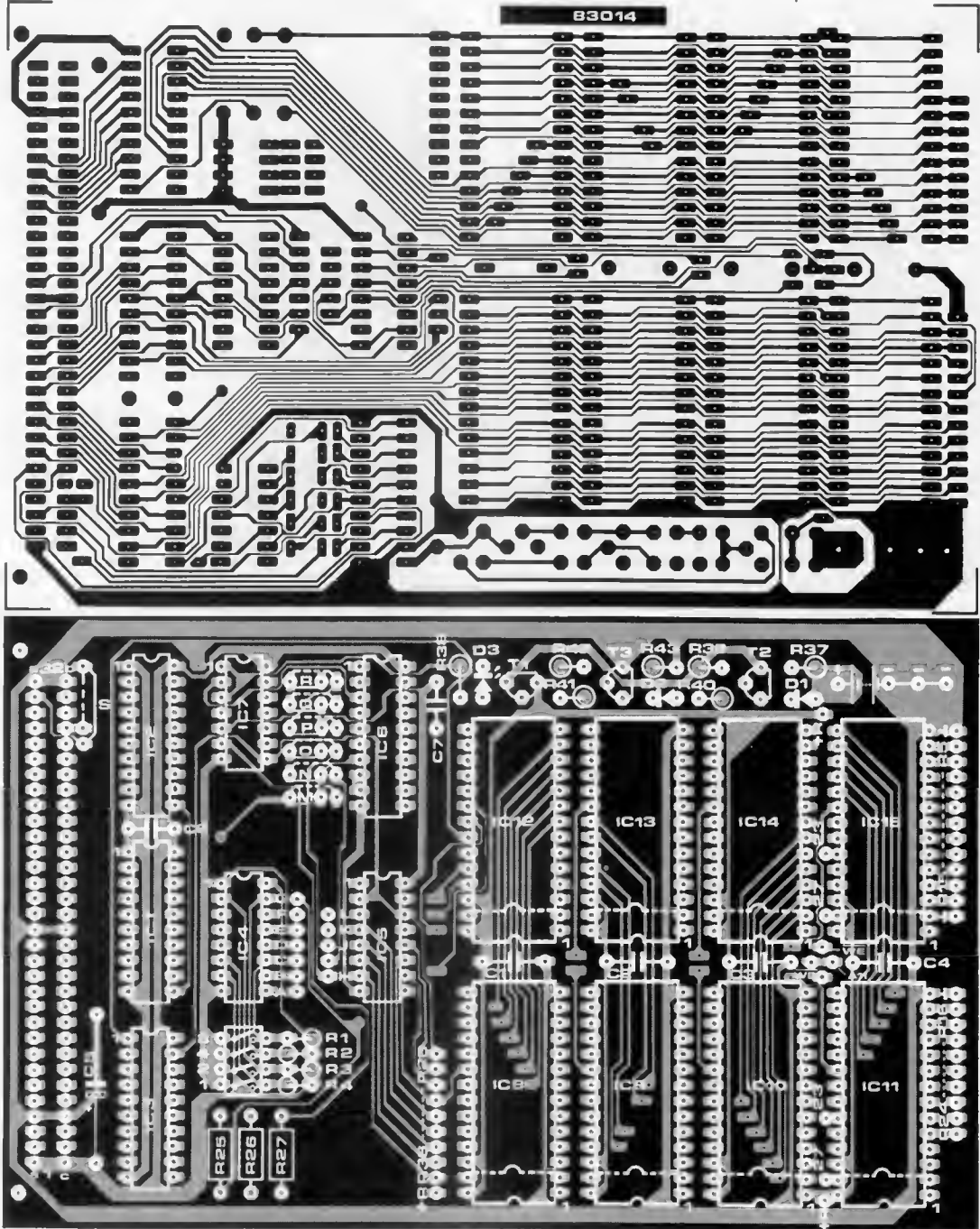

used at different clock frequencies. There shouldn't be any problems unless fast CPUs are used, in which case it may be necessary to use faster EPROMs. The RAMs are fast enough (250ns).

Control signal delays are also important in this context. The \overline{MREQ} signal appears as the \overline{CE} signal at the RAMs or EPROMs after a (typical) delay of 50 ns, caused by IC3 (10 ns), N9 (10 ns), IC5 (20 ns) and IC3 (10 ns). The delay for the $\Phi 2$ signal is: N5 (10 ns) – N3 (10 ns) – N10 (10 ns) equals 30 ns (typical), after which it appears as \overline{OE} or \overline{WE} . In this case the \overline{CE}

signal is obtained from the addresses. The delay caused by the data bus buffers is 10 ns (typical). For these purposes we have assumed that the addresses are already present, i.e. that they have already passed the buffer and adder. Otherwise an additional delay of 37 ns (typical) would have to be added for this path.

Construction

Before mounting any components on the p.c. board (figure 6), it is always a wise precaution to check the board for short-

Wire links M – S:
8088
8085 SC/MP 6502 Z80

M
N
O	normally	---	---
P
Q	---	---	---
R	---	---	---
S	---	---	---

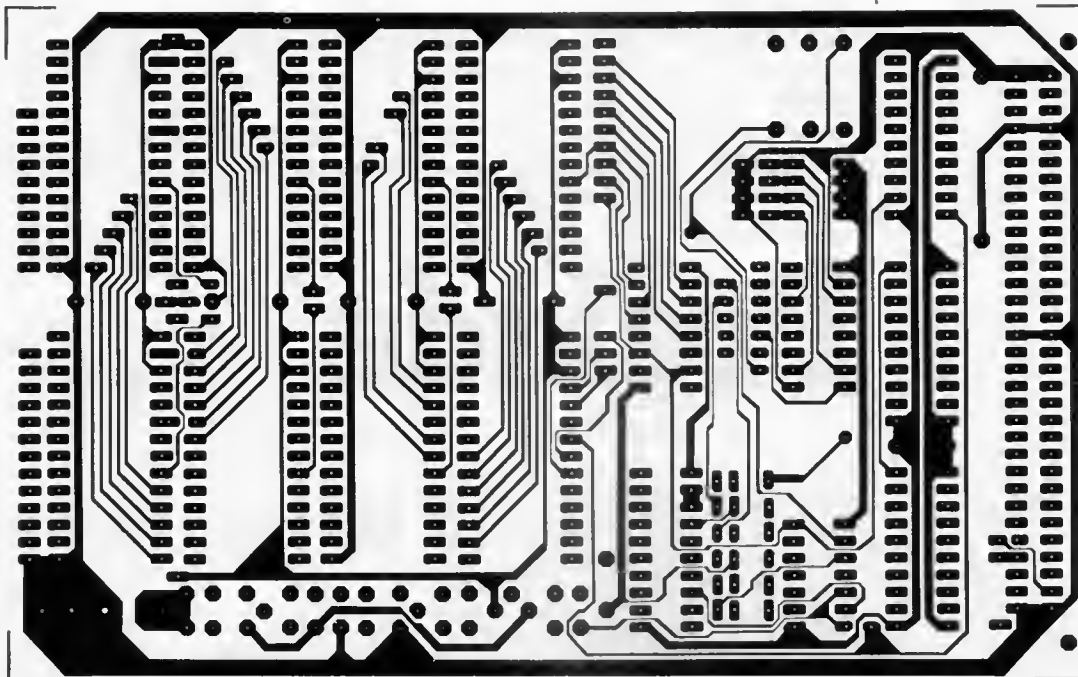

Parts list for MOS version

Resistors:

R1 ... R4 = 1 k

Capacitors:

C1 ... C4, C6, C7 = 100 n
C5 = 10 μ /16 V

Semiconductors:

IC1, IC2 = 74LS373
IC3 = 74LS245
IC4 = 74LS283
IC5 = 74LS155*
IC6 = 74LS240
IC7 = 74LS10*
IC8 ... IC15 = RAM
and/or EPROM
see text, figures 4 and 5
* different from CMOS
version

Miscellaneous:

IC sockets
4-pole DIP switch
64-pin connector

Parts list for CMOS version

Resistors: $\frac{1}{8}$ W

R1 ... R4 = 1 k
R5 ... R25 = 100 k*
R26 ... R36 = 1 k*
R37 see text
R38 = 470 Ω
R39 = 2k7
R40, R41 = 10 k
R42 = 220 Ω
R43 = 68 Ω

*Note that 18 of the 100 k resistors can be replaced by two 9x100 k single-in-line resistor networks; similarly, one 9x1 k network can replace nine of the 1 k resistors.

Capacitors:

C1 ... C4, C6, C7 = 100 n
C5 = 10 μ /16 V

Semiconductors:

D1 = AA119
D2 = 1N4148
D3 = LED red (not high efficiency)
T1, T2 = BC 557B
T3 = BC 547B
IC1, IC2 = 74LS373
IC3 = 74LS245
IC4 = 74LS283
IC5 = 74LS156
IC6 = 74LS240
IC7 = 74LS12
IC8 ... IC15 = CMOS-
RAM 6116, 5564 or
similar see text,
figures 4 and 5
Miscellaneous:

IC sockets
4-pole DIP switch
64 pin connector
2 ... 3 NiCd-cells or
disposable batteries
see text
Nicaid: 20 PK
silveroxide: V 76 ris
mercury: V 675 PX

Figure 6. One p.c.b. for both versions (see parts lists). Readers wishing to use a memory card for experimenting with different processors should solder wires to the centre contacts of the 'wire link switches' on the p.c.b. and fit plug-in connectors to the free ends. Matching pins are then inserted into the terminals for the remaining contacts. The memory card then becomes truly universal.

Wire links A ... L when using:

2 K RAM and EPROM:

G - L
F - K
E - J
D - I
C - H

4 K EPROM:

F - L
E - K
D - J
C - I
8 - H

8 K RAM and EPROM:

E - L
D - K
C - J
B - I
A - H

circuits, faulty tracks and continuity of the plated-through holes, using an ohmmeter or continuity tester. In general, however, boards supplied by Elektor should be in order.

The wire links that determine the processor type can now be inserted and the IC sockets soldered in. At this stage it is well worth taking the trouble of checking continuity in the IC sockets. Subsequent fault-finding is extremely tedious ... The next step is to mount the resistors if it is going to be a CMOS RAM card. If the resistor networks specified in the parts list for the CMOS version are not available, normal resistors can be used instead. They are inserted vertically, and their free ends are inter-

connected and brought down to the common terminal on the p.c.b. Mounting the remaining components should be no problem. Note that IC5 and IC7 are different for the CMOS and MOS versions!

It is best to use two solderable, miniature nickel cadmium cells as the backup supply for a CMOS RAM. Large batteries will not fit on the p.c.b., but they can always be connected with two wires.

This memory card should provide any personal computer with sufficient memory space. It should be noted that the card is designed for the Elektor bus. If it is to be used with other buses, an adapter must be improvised.



Prelude, the preamplifier in the Elektor XL range, is shaping up nicely! Literally, this month: all the modules, switches and controls are mounted on the bus board. This means that the final 'shape' is now defined, as well as the appearance: we can provide the front panel, and you can start looking for a suitable cabinet.

The line amplifier is also described. This is a straightforward module: it provides linear no-nonsense gain. And, elsewhere in this issue, the 'audio traffic lights': that circuit will also be incorporated in the Prelude.

Prelude

(Part 2)

bus board
and
line amplifier

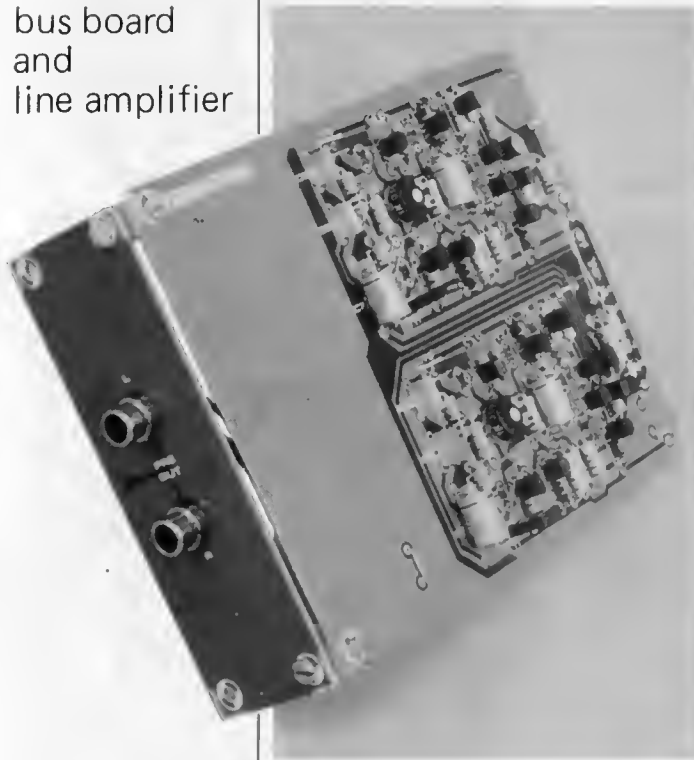

Don't be so impatient! It seems incredible, but we have already received several letters from readers who are building the Prelude. Some are asking for more advance information; others are offering suggestions for the design. To both groups, our answer is: 'Read on!' So far (to our relief!) we have not received any design suggestions or requests that are not already included or surpassed in the Prelude.

This month, the bus board and front panel make our intentions clear. All control functions are described, and the final interior measurements are known. Impatient constructors can start on the cabinet! Furthermore, we will give an extensive description of the line amplifier. Hopefully, this will satisfy those readers who have stressed that the design should be impeccable: the same basic circuit is used throughout the

Prelude!

Enough of this. Let's get down to the nitty-gritty:

The bus board

This board forms the basic for all the modules, switches and other controls. Witness its dimensions: 43.5 x 11.5 cm! These 'peculiar' measurements didn't just happen: the board is tailored to fit standard 19" cabinets.

The circuit shown in figure 1 is really little more than a wiring diagram for the various modules. R39... R42, D5... D7, T13 and T14 are part of the audio traffic-light, described elsewhere; the section around the volume and balance controls will be discussed when we come to the line amplifier.

To avoid misunderstandings (these could prove rather frustrating at a later date) the final position of the bus board must be made absolutely clear. The copper track side faces the front panel, and the modules are mounted on the component side - at right-angles to the bus board, of course. Viewed from the front, the EPS p.c.board number on the copper track side should be at the upper left.

The connections to the modules are indicated in figure 1. Any further explanation of the circuit would be redundant; instead, we will explain the controls. That should clarify the circuit (figure 1), the front panel (figure 2) and, last but not least, the Prelude.

The phono switch (S1) is not mounted on the bus board; it will be discussed in detail when we come to the MM/MC preamplifier. For the moment, suffice it to say that this control selects one of three inputs: one for Moving Coil cartridges and two for Moving Magnet (or 'dynamic') inputs.

One of the five input signals is selected by the input switch (S2) and passed to the control amplifier section. In combination with the phono selector switch, this means that there are actually seven signal inputs. The input sensitivities are individually adjustable, by means of presets on the phono preamp board and the connecting board.

The tape 1 input and tape 2 input switches (S8 and S9, respectively) each select one of

2

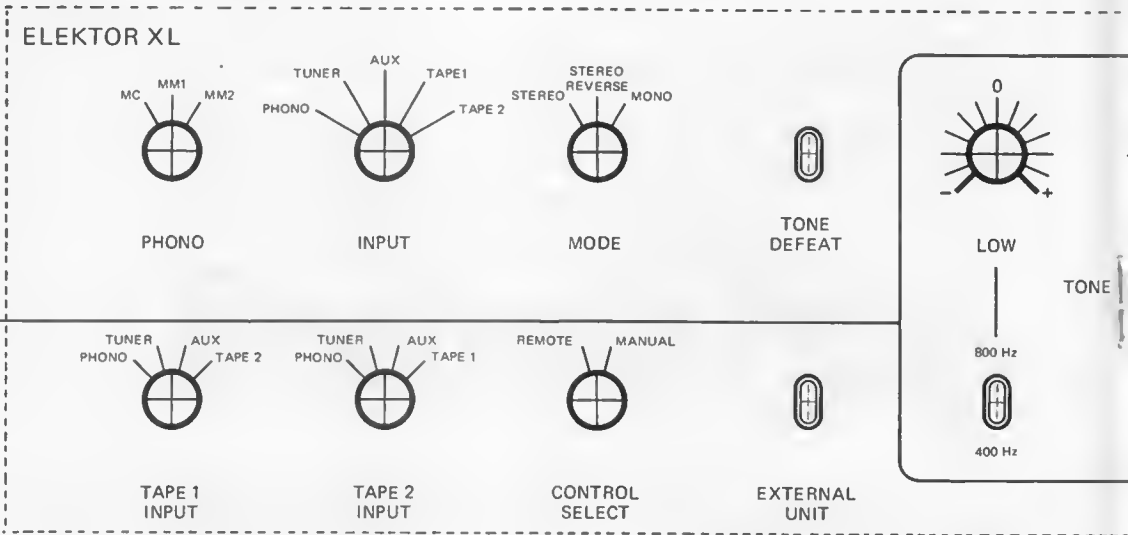

3

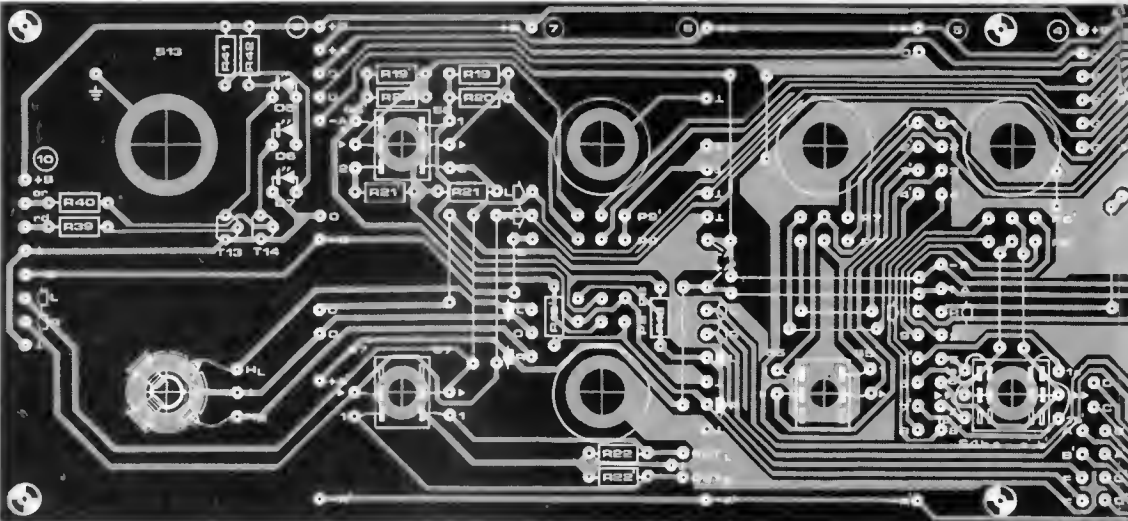
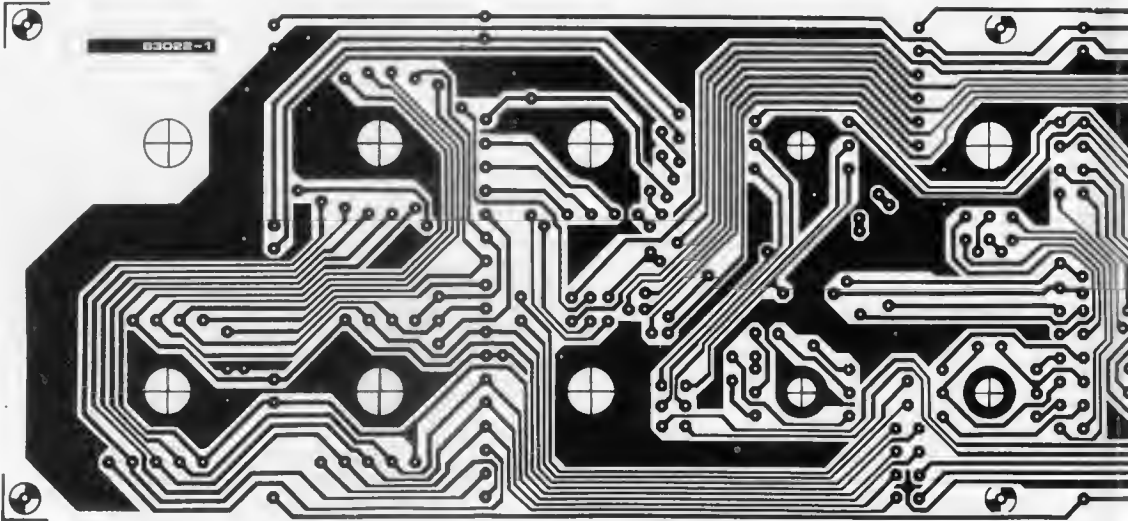

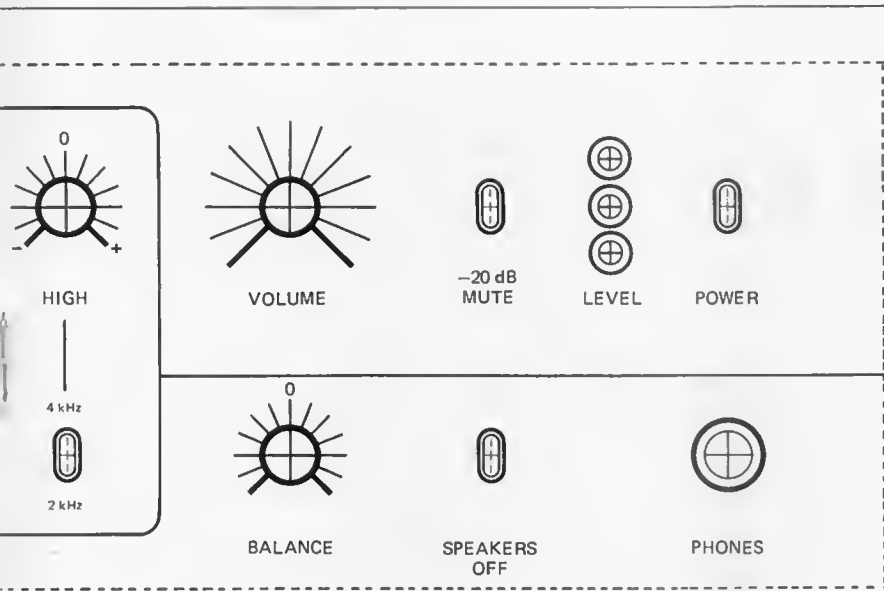
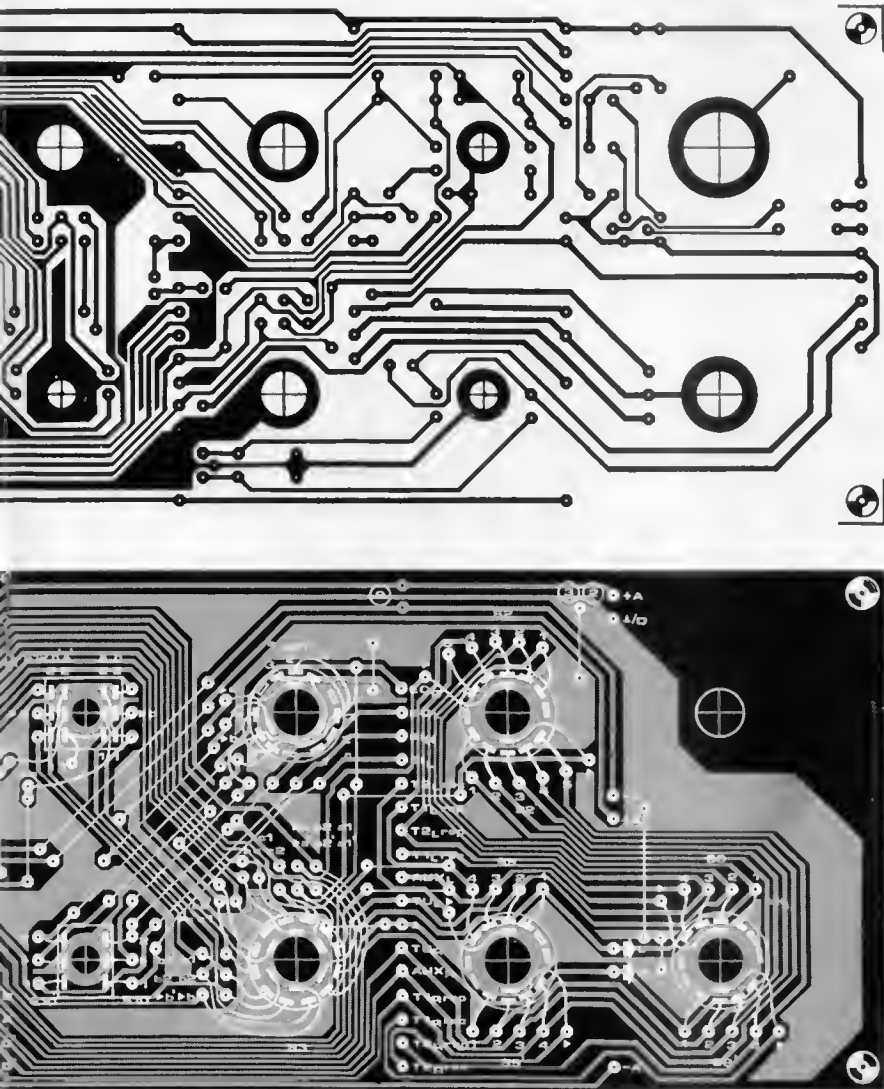

Figure 2. The Prelude's front panel (shown here at reduced size). The main controls are all located above the centre line, with the auxiliary controls below. The tone control section is also clearly indicated.



Perts list for the bus board

- S2 = 2-pole 5-way rotary switch
- S3 = 6-pole 2-way rotary switch
- S4,S12 = 4-pole 2-way miniature toggle switch
- S5,S6,S7,S10 = 2-pole 2-way miniature toggle switch
- S8,S9 = 2-pole 4-way rotary switch
- S11 = 3-pole 3-way rotary switch
- P6 = 50 k lin stereo potentiometer
- P7,P8 = 10 k lin stereo potentiometer
- P9 = 1 k log stereo potentiometer
- R18,R18' = 1 k
- R19,R19',R20,R21' = 1k8
- R21,R21' = 120 Ω
- R22,R22' = 470 k
- R39,R40 = 27 k
- R41,R42 = 1k2
- D5 = red LED
- D6 = orange LED
- D7 = green LED
- T13,T14 = BC 547B
- one stereo headphone output socket
- one mains switch (toggle type)

* these components are part of the 'audio traffic lights' status indicator circuit

Figure 3. The bus board. For obvious reasons, this cannot be reproduced at full size. Virtually all the controls and modules are mounted on this board, reducing the wiring to a minimum.

the input signals for recording on an associated tape deck. The setting of the main input has no effect on these switches. In other words, it is quite feasible to make a recording from one signal source (the record player, say) while listening to a different signal (the radio) via the headphones or loudspeakers. This system makes a 'tape monitor' switch redundant. Take an example: you want to make a recording from the radio, using tape deck 1, and monitor the recording. In this case, the tape 1 input selector is switched to 'tuner' and the main input switch is set to 'tape 1'. To switch back to the 'source' signal, for comparison with the recording, the main input selector is switched to the 'tuner' position. Another possibility is to make a copy of a tape, using both tape decks. Say that the master tape is on the second machine: its output signal is passed to the first deck when the tape 1 input switch is set to the tape 2 position. In fact, you don't even need to switch on the Prelude – unless you want to monitor the recording, in which case the main input selector can be set to tape 1 (monitor) or tape 2 (source). No messing around with cables: just flip the switches!

The control select switch (S3) allows you to switch over to a remote control unit, if this is included in the system. In one position of the switch, the remote control unit is switched completely out of the circuit, so that it cannot have any effect on the signal quality; in the other position, the main input selector, tone, volume and balance controls of the Prelude are rendered inoperative and the remote control unit takes over these functions. A suitable control unit will be described in the near future.

The external input switch (S10) is intended for inserting some auxiliary circuit in the main signal path, between the input selector and the tone controls. The 'auxiliary circuit' can be almost anything: a noise reduction system, equalizer, reverb unit or whatever. If you really want to, you can even include a third tape deck: the external input switch does the same job as the old 'monitor' switch.

The mode switch (S11) is self-explanatory: it offers a choice between normal stereo, stereo-reverse (left and right channels transposed) and mono.

The tone control section is clearly indicated on the front panel. It contains an 'adequate minimum': bass and treble controls (P6 and P7) and two switches (S4 and S5) for selecting the turnover frequencies.

Equally important, certainly for purists, is the tone defeat switch (S12): it renders the complete tone control section inoperative.

The volume and balance controls (P9 and P8) do exactly what you would expect . . .

The mute switch (S6) attenuates the output signal by 20 dB. This can be useful when answering the telephone, for example: the output level can be reduced drastically at the flick of a switch, without having to alter any of the control settings.

The speakers off switch (S7) disconnects the main output to the power amplifier, when using headphones only.

Finally, there are three 'level' LEDs that

belong to the 'audio traffic lights' (described elsewhere in this issue), the mains switch ('power') and the headphone output.

Things are taking shape

The dimensions of the bus board are such that we can only fit a 70% reduced reproduction on these pages (figure 3). As mentioned earlier, it is designed to fit a 19" cabinet.

Before actually mounting any components, it is a good idea to check whether all the switches, potentiometers and the headphone socket fit neatly through the holes provided. Note that the phono switch (S1) is not mounted on the bus board: it is located on the preamp module, with the spindle protruding through the small hole in the bus board.

Good quality rotary switches and potentiometers should be used: crackly controls and worn switches can be sheer frustration in a project of this nature! The other switches can be miniature toggle types, and the holes in the bus board are designed to accept them. The mains switch should be a more robust device, of course, and its hole is correspondingly larger.

All the potentiometers and switches are inserted in the board from the component side, with their spindles or toggles protruding on the copper track side. In other words, the copper faces the front panel. Short wire links are used to connect the controls to the board. The wiring to the potentiometers is straightforward, but some of the switches are more complicated. Take careful note of the indications shown on the board and refer to the circuit when wiring the rotary switches. The mode switch is even more complicated, since the wiring is all mounted between the tags on the switch itself: the board merely provides the connections to and from this switch.

The toggle switches and headphone socket are all connected to corresponding solder pads on the board. With one exception: the mains switch. For obvious reasons, the mains lead is connected directly to the switch itself; the copper ring on the board under this switch can be connected to mains earth.

The handful of resistors, T13 and T14 and the wire links are all mounted on the component side of the board in the indicated positions. The three LEDs are mounted on the copper side of the board, in such a way that they are just flush with the front panel. This means that their height above the bus board will depend on the distance between this board and the front panel.

All the completed modules can now be mounted on the bus board. So far, we have described the power supply, the connecting board and the headphone amplifier. This month, we are adding the line amplifier and the status indicator (the 'audio traffic lights'). The positions of these boards were indicated in part 1, figure 3. It is advisable to use fairly stiff leads for the wire link connections between the boards, since this makes for a more rigid construction. Note that the links can be mounted on either side

**Parts list line amplifier****Resistors:**

R1,R1' = 1 M
 R2,R2',R4,R4' = 68 k
 R3,R3' = 3k3
 R5,R5',R10,R10' = 2k7
 R6,R6' = 2k2
 R7,R7',R8,R8' = 4k7
 R9,R9' = 22 k
 R11,R11',
 R16,R16' = 330 Ω
 R12,R12',
 R17,R17' = 680 Ω
 R13,R13',
 R14,R14' = 10 Ω
 R15,R15' = 1 k
 P1,P1' = 1 k preset

Capacitors:

C1,C1',C4,C4' = 22 μ /10 V
 C2,C2',C7,C7' = 220 μ /4 V
 C3,C3' = 33 p
 C5,C5',C6,C6' = 100 n
 C_x,C_x' = 22 p*

Semiconductors:

T1 ... T3,T1' ... T3',
 T8,T8',
 T12,T12' = BC 550C
 T4 ... T7,T4' ... T7',
 T10,T10' = BC 560C
 T9,T9' = BD 140
 T11,T11' = BD 139

Miscellaneous:

2 cinch-type output
 sockets, screw mounting

of the module boards. The size of the actual potentiometers and switches used determines whether it is more practical to mount the connecting links on the copper side of a given module instead of on the component side: either way may give just that little extra room that is needed.

No matter how the connections are made, one thing is important: the links must be made between corresponding points on the module and the bus board! In practice, this means that the orientation of the boards differs. For the modules described so far, the component side of the connecting board, headphone amplifier and power supply face towards the right-hand end of the cabinet;

the line amplifier and 'audio traffic lights' face the other way.

The connections between the mains input, fuse, switch, transformer and supply board should be tied down to the cabinet at regular intervals. Keep them well away from the sensitive input circuits!

By now, we can get a clear impression of what the complete Prelude is going to look like. The missing modules will be the same size as those already mounted, so the final internal measurements are known. If you like, you can start working on the cabinet!

The line amplifier

This module accepts the output signal from

* Note that capacitors C_x and C_x' must be mounted on the copper-track side of the board, across R4 and R4'. No mounting holes are provided!

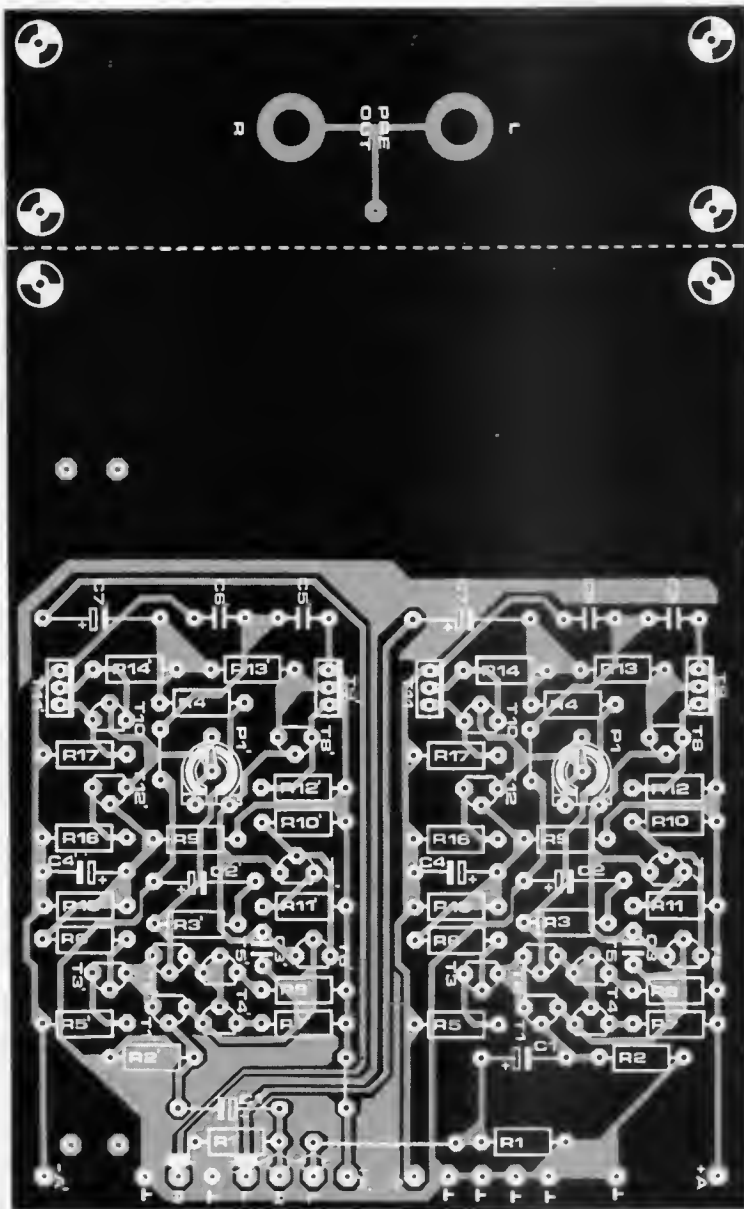

Figure 5. The printed circuit board for the line amplifier consists of two sections; these must be separated before any components are mounted, and the smaller section that accepts the output sockets is mounted at rightangles along the rear edge of the main board. Note that the connections from the bus board to the output sockets must be made with screened cable, running along the lower edge of the module; two pairs of solder pads are intended for mounting wire bridges to hold the cable neatly in position.

the tone control section and boosts it to a level that is sufficient to drive the power amplifier. In our case, this corresponds to a voltage gain of about 26 dB (x 22).

As shown in figure 4, the same 'discrete opamp' circuit is used as in the headphone amplifier. Why all this complexity, when you can obtain complete single, dual and even quad opamps in a DIL package? As you might expect, it's a question of performance: the discrete version is superior to the integrated type. It produces less noise, has a higher slew-rate and a larger open-loop gain. Admittedly, some very good integrated op-amps exist, but they also have a disadvantage: they are expensive . . .

Having said all this, it is worth taking a closer look at the circuit. Transistors T1 and T2 are connected as a differential amplifier (or 'long-tailed pair'). The common emitter connection of these transistors is connected to a current source (the 'tail') that maintains a constant total current through the two transistors, independent of the base drive (over the range that we are interested in, that is). The current source, T3, is set so that the current through T1 and T2 corresponds to the minimum-noise value for these devices. The collector load for T1 and T2 consists of a current mirror (T4, T5). This effectively blocks supply ripple and ensures that a 'clean' output signal is passed to the next

stage. Incidentally, the current mirror also boosts the output from the first stage. This may not be immediately apparent, but think of it this way: assume that the input swings negative, so that T1 draws less current and T2 draws proportionately more. This larger current must also pass through T5, and the current mirror operation forces the same larger current to flow through T4. So we have more current flowing down towards T1, at the same time that the current through this transistor is decreased by the same amount. In effect, therefore, the output current from this stage is doubled; or, to put it another way, the voltage swing at the collector of T1 is the result of the combined efforts of T1 and T4.

The current mirror itself is not perfect – that would require perfectly matched transistors and a compensation mechanism for the common base drive current. However, for this application two discrete devices of the same type are good enough, and the emitter resistors (R7 and R8) help to reduce the effect of any differences in their characteristics.

The high output impedance of the first stage means that the next stage should have a high input impedance. This is achieved by using a Darlington configuration (T6, T7). The collector load for the Darlington is another current source, T12, so that the total gain is quite high.

The output stage consists of two 'super-Darlingtons' (T8/T9 and T10/T11) in a class-A push-pull configuration. This makes for very low distortion and good load-handling capability. P1 sets the quiescent bias current through the output stage.

Capacitor C3 provides the frequency compensation needed for good stability. Don't be misled by the low value: this capacitor is connected between two very-high-impedance points.

The closed-loop gain of the opamp is determined by the feedback to the base of T2: by the ratio of R3 to R4, in other words. To be precise, the overall gain is $A = 1 + \frac{R4}{R3}$; with the values shown, this works out at 22 times. For DC the circuit has unity gain, owing to the effect of C2; the -3 dB point is approximately 5 Hz.

Finally, a few words about the current sources. R9 and R15 constitute a voltage divider, so that there is a drop of about 1.3 V across R15. Capacitor C4 serves to smooth this voltage, effectively eliminating any supply ripple or other undesirable interference. The bases of both T3 and T12 are connected to this point. The voltage drop across the emitter resistors must therefore be constant: 1.3 V minus the 0.6 V base-emitter drop (0.6 V is a closer approximation than 0.7 V at the small currents involved). A fixed voltage drop can only appear across a fixed resistor if the current is also constant, and the same current must flow in the collector of the associated transistor. Hence, the whole circuit works as a current source, with the current being determined by the value of the emitter resistor. The output from the line amplifier is fed to the balance and volume controls. These were

shown in figure 1. The balance control is wired in such a way that it does not quite provide a constant total output: as it is rotated away from the mid position, one channel is attenuated and the gain in the other channel only increases marginally – not quite enough to keep the total output apparently constant. In practice, this type of control characteristic gives a more natural effect than the constant level type.

As described earlier, the mute switch provides a 20 dB drop in level: R19 . . . R21 and P9 work as 1:10 voltage divider. The volume control, P9, is at the output of the preamplifier. This has the advantage that any noise produced by the circuit is reduced as the output level is turned down, thus effectively maintaining the same signal-to-noise ratio. There is no need to incorporate this control at an earlier point, since there is no danger of overloading any of the preceding stages. They all have adequate headroom, and the sensitivity of each input is adjusted to suit the associated signal source by means of the presets described earlier.

Construction

The line amplifier p.c.b. is shown in figure 5. The section with the output sockets must be separated from the main board, and mounted at rightangles on the rear edge. The completed module can be mounted on the bus board at the indicated position, near the volume and balance controls. The resistors associated with these controls and the mute switch are located on the bus board. The quiescent current through the output devices (T9/T11 and T9'/T11') must be set to 15 mA, by means of P1 and P1'. The procedure is as follows:

- Rotate P1 and P1' fully *clockwise*, viewed from the component side of the board. This sets the wiper at the free end of the potentiometer, effectively shorting it.
- Connect a multimeter between the collectors of T9 and T11 (across R13 and R14, in other words); the collector of T9 is the positive connection.
- Now (and not before!) switch on the Prelude. Rotate P1 slowly until the meter indicates 320 mV.
- Repeat the procedure for the other channel (P1').

If you like, you can now check the various voltages indicated in figure 4. The DC level at the R13/R14/C7 junction should be within 50 mV of 0 V.

One final note, regarding the construction: the connections from the bus board to the output sockets should be made with screened wire, of course. This cable should run along the lower edge of the line amplifier board, on the copper track side. In two places, a pair of copper pads are provided on the board. The idea is to mount a little wire bridge over the screened cable at these points, to hold it neatly in place. That's it, for this month. In part 3 we will describe the tone control section and the phono preamps. After that, you can start putting Prelude through its paces!

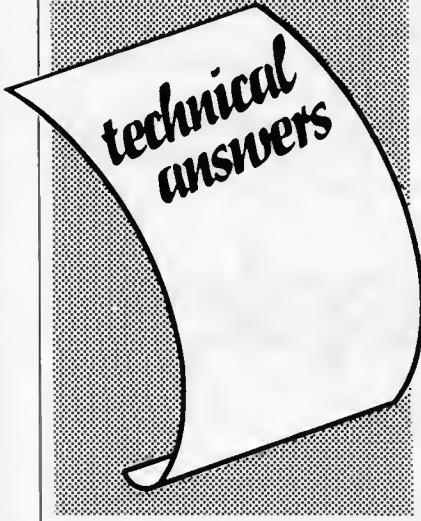

ceiver. However, there is a small problem in practice: video outputs are standardised at a level of $1V_{pp}$, whilst the video text decoder requires an input voltage of $2.6V_{pp}$. This is no problem if one connects the video signal amplifier illustrated here between them. The amplification can be set between 0 and a factor of 4 by means of the trimmer.

siderably saving in circuitry, but we then lose our polyphonic tone formation. The first key to be pressed triggers the envelope curve; a note that is subsequently played by another VCO then drops into the deceiving envelope curve of the existing note. This then brings us back to monophonic playing or chords only.

The microcomputer as a source of interference

'Whenever I work with my microcomputer the FM-radio has a high noise level. What causes this interference and what can I do about it? Every microcomputer system operates with relatively fast logic ICs, such as Schottky TTLs. This means that the digital signals have rapid-rise slopes which produce harmonics extending far into the VHF/UHF region. This causes interference, and not only to FM stereo reception. The problem is not restricted to home made microcomputers; some commercially built microcomputers, particularly teaching and experimental systems, can unfortunately be classed as sources of electromagnetic pollution. The only solution is to install the microcomputer in a (metal) screened housing with an earth connection; it may also be necessary to fit a mains RF-suppression filter. Screened (coaxial) cable should be used for connections between the computer and peripheral equipment. These precautions apply to all digital equipment using fast logic.

When is a buzzer not a buzzer?

All buzzers were not created equal and the conditions required to make them buzz vary from one type to another. The 'piezo-buzzer' frequently used by Elektor (see circuit symbol below) is actually a high-impedance miniature loudspeaker (piezo-electric) with a high degree of efficiency over the frequency range between 3.5 and 5 kHz, with a maximum at 4.6 kHz. Like every other loudspeaker, an audio-frequency signal must be applied to it. The circuit therefore contains an oscillator to generate this signal for the buzzer.

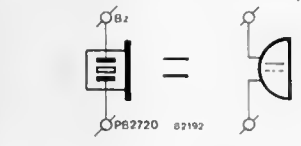

Miniature d.c. buzzers are commonly available; these must be operated with a d.c. voltage. These are not intended for use in circuits designed for 'passive' piezo-electric buzzers and vice versa. So please check the type of buzzer specified in the circuit diagram and text to avoid any problems. Why does Elektor use passive piezo-electric buzzers? Because of the low current consumption and more pleasant sound.

Dynamic RAM card for ZX81

How do you connect the 16K Dynamic RAM card (April 1982) to a ZX81? This is a fairly simple job:

- disable the ZX81's internal 1K memory, by connecting pin 2A on the connector (RAM CS) to the +5 V supply.
- connect address line A15 on the dynamic RAM card to supply common. (Don't ask us why...)
- mount the wire links for a Z80, according to table 1 in the original article (p. 4-33).
- connect the address and data lines, WR, RD, MREQ and RFSH to the corresponding points in the ZX81, with the exception of address line 15 as mentioned above.
- mount wire links from points 4, 5, 6 and 7 near IC11 to V, W, X and Y, to locate the card from address 4000H.

Polyphonic simplification

A 'real' polyphonic synthesizer requires complex circuitry, a fact which seems to have prompted many readers to come up with ideas for simplifying the circuitry. We are grateful for the many suggestions, although none of them has yet provided the ultimate in simplification. One proposal that is frequently encountered is to arrange for only the VCOs to be polyphonic and to operate them jointly via a single VCF or VCA. This involves a con-

Video text without a receiver

Readers who own a home video recorder with video output can dispense with the receiver p.c.b. of the Elektor video text receiver and connect the decoder to the video output of the recorder. In this case, the TV tuner of the recorder serves as re-

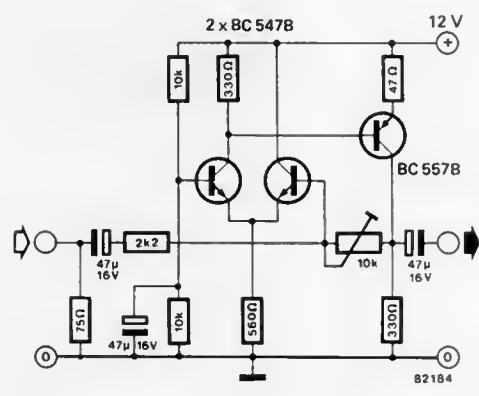

The clarity and legibility of a light-emitting display is governed more by its contrast with the background at minimum brightness, than by the brightness of the illuminated characters. There is a direct relationship between brightness of the background and ambient light, and so a desirable feature is for the brightness of the display to adapt itself automatically to ambient light so that the contrast remains the same. The OPL 100, a monolithic integrated display-dimmer, has been specially developed for this purpose.

automatic display-dimmer

constant
contrast

Figure 1. The OPL 100 is an opto-electronic sensor, intended for automatically matching the brightness of light-emitting displays to the ambient light. The chip is accommodated in a transparent 8-pin dual-in-line package and includes a photo-sensitive diode in addition to the necessary control electronics.



For clear readout under varying ambient light conditions, the brightness of the display needs to be proportional to the amount of ambient light, so that the display becomes dimmer as the ambient light decreases. The range of variation must however be limited, since a minimum amount of brightness is required to enable the characters to be read in total darkness. The brightness range also must have a maximum limit in order to prevent the display from being damaged. In principle, regulating the brightness of a light-emitting display is synonymous with regulating its current or voltage. This may sound simple, but is beset with problems when put into practice. Displays are usually driven directly by a special IC with a rather narrow supply voltage range, and by varying this alone it is not possible to regulate the brightness. If the display driver is provided with a blank-input, there is a better solution. Since a logic level at this input determines whether the display lights up or not, applying a square-wave of sufficiently high frequency to the blank-input will reduce the average current through the display. Furthermore, the duty cycle of the square-

wave determines the apparent brightness. Even if there is no blank-input, duty-cycle regulation can be employed by means of additional circuitry which we will examine later.

To be able to regulate the brightness of the display (i.e. the current through it) as a function of ambient light, we can make use of an ABC-sensor (automatic brightness control) specially developed for the purpose. The OPL 100 (TRW Optron) is an 8-pin IC (see figure 1) which is encapsulated in a transparent package. It contains a photodiode having a light-sensitive surface of 1.7 mm². As shown in figure 2, it also contains a temperature-compensated current amplifier, an operational amplifier set for unity gain, four comparators, one flip-flop, an output buffer and some control logic. In addition to all that it also features an on-chip voltage stabiliser which can handle supply-voltages ranging from 4.5 to 24 V. With an external RC network (R_x and C_x) connected to pin 5, a sawtooth voltage is produced as the capacitor is alternately charged through R_x and discharged via the internal transistor. The frequency is approxi-

mately equal to $\frac{1.4}{R_x C_x}$. The sawtooth voltage varies between two limits established by comparators U_{LOW} and U_{HIGH}, and the 'signal' comparator compares this voltage to a voltage at pin 1 that is derived from the ambient light. During each period of the sawtooth waveform, this voltage will initially be less than the voltage at pin 1; the 'signal' comparator ensures that the output (pin 7) is positive. As soon as the sawtooth waveform rises above the voltage at pin 1, the output of the 'signal' comparator and hence the output at pin 7 goes low (approximately 0.4 V), as shown in figure 3.

As the ambient light intensity increases, so does the voltage at pin 1. It will take longer for the voltage at pin 5 to exceed it, and so the output at pin 7 remains positive for a longer part of the period. This results in increasing brightness of the display, maintaining constant contrast. Since the upper limit of the sawtooth volt-

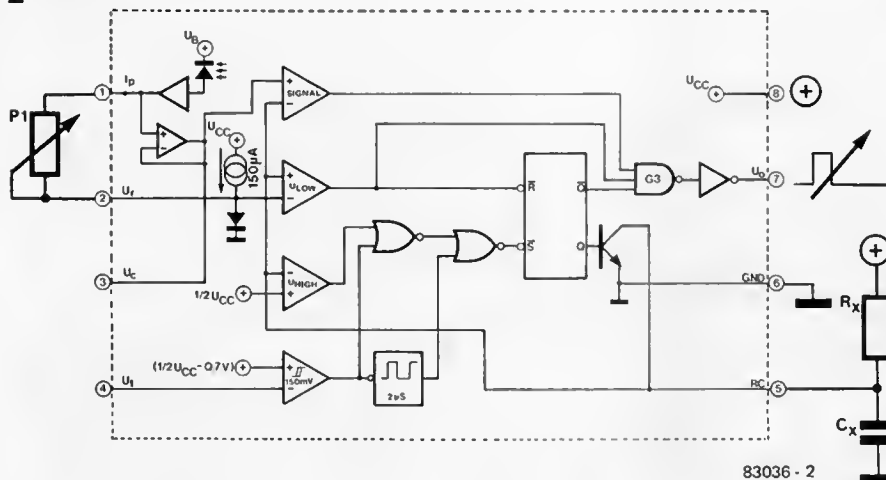

Figure 2. The internal structure of the OPL 100. R_x and C_x are the external components for a sawtooth generator. Comparators are used to derive a square-wave from the sawtooth voltage; the duty cycle has a linear relationship to the ambient light measured by the photo-diode. The square-wave voltage, with its varying duty cycle, is used for brightness control of the display.

age $\frac{U_{CC}}{2}$ follows any variations in the supply voltage (U_{CC}), the frequency of the sawtooth voltage is independent of the supply voltage. As the supply voltage drops, however, the duty cycle ($T_P : T$) of the output voltage will increase. When the ABC-sensor is used in battery-powered equipment, this effect will help to counter the decrease in display brightness caused by any decrease in supply voltage. The duty cycle, and hence the brightness of the display at a particular ambient light intensity, can be adjusted with P1.

A buffer amplifier output voltage is present at pin 3 which is a function of ambient light intensity. This is intended for use when several ABC display-dimmers are used in a large system: this voltage from one (master) sensor can be connected to pin 1 of the other (slave) dimmers, resulting in the same brightness over the total display area. The trigger input (pin 4) makes it possible to synchronise the output pulses by means of an external signal. This is necessary with multiplexed displays for example, to be covered later. If the trigger input is grounded, then the sawtooth generator stops and no output voltage is present (display is turned off). For the basic (asynchronous) mode described so far, the supply voltage should be applied to this input.

Use of the ABC-sensor is not restricted to LED displays; fluorescent displays are again gaining ground, and they can be provided with variable brightness if their grid voltage is controlled by means of this sensor.

Basic circuit

Figure 4 shows a basic circuit using the OPL 100. It will control a display so that it becomes brighter in intense ambient light and less bright in the dark. The sensitivity can be adjusted with pin 1 and resistor R1 ensures that the display does not go out completely at low ambient light levels. The level at which this becomes noticeable depends on the value of R1 and the setting of P1; the value of R1 should be between

3

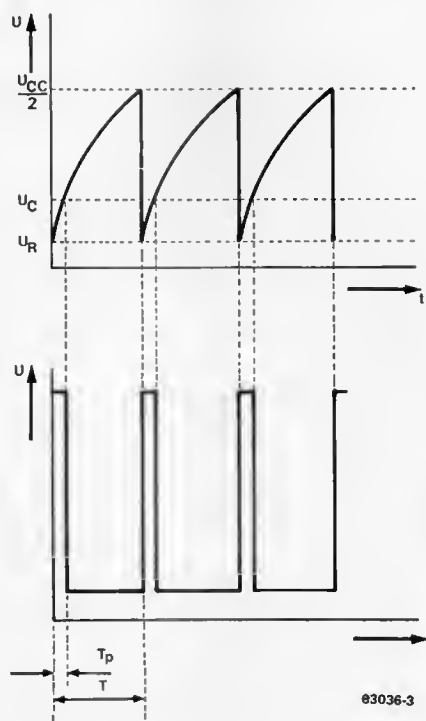

Figure 3. The basic operation of the OPL 100 is illustrated here. The sawtooth voltages vary between two limits, and when it crosses the threshold voltage U_C the output voltage U_O changes level. As the intensity of the ambient light varies, the threshold U_C shifts and the duty cycle of the output voltage U_O varies accordingly.

100 k and 2M Ω . Lower values result in greater brightness in the dark. The task of capacitor C3 is to suppress the 100 Hz 'ripple' generated by artificial lights. This is especially important when the displays are multiplexed, as a stroboscopic effect might otherwise result in noticeable flickering of the display.

A similar problem can occur if the frequency of the ABC output can interact with the multiplex frequency. This can be eliminated by synchronising the ABC-sensor with the multiplex signal, via the trigger input (pin 4) of the OPL 100. The positive edge of the

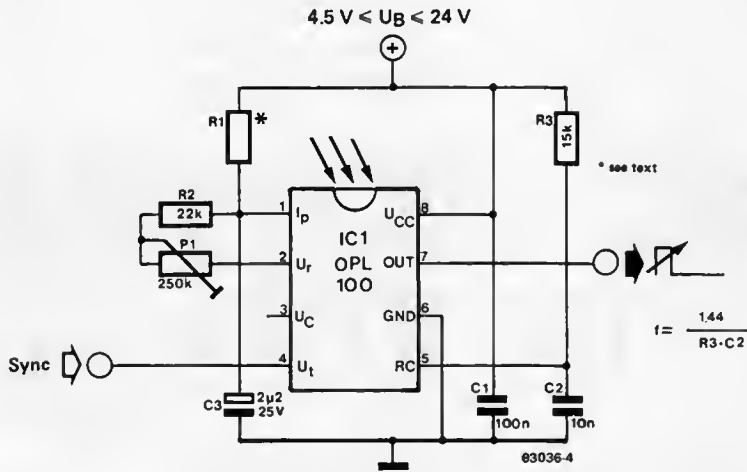

Figure 4. The basic circuit of the OPL 100. The sensitivity can be adjusted with P1. Resistor R1 is included in order to ensure that the display does not become too dim when insufficient light impinges on the OPL 100. Capacitor C3 suppresses the 100 Hz light ripple generated by artificial lighting. To prevent flickering of multiplexed displays, the OPL 100 can be synchronised with the multiplex signal via the trigger input (pin 4).

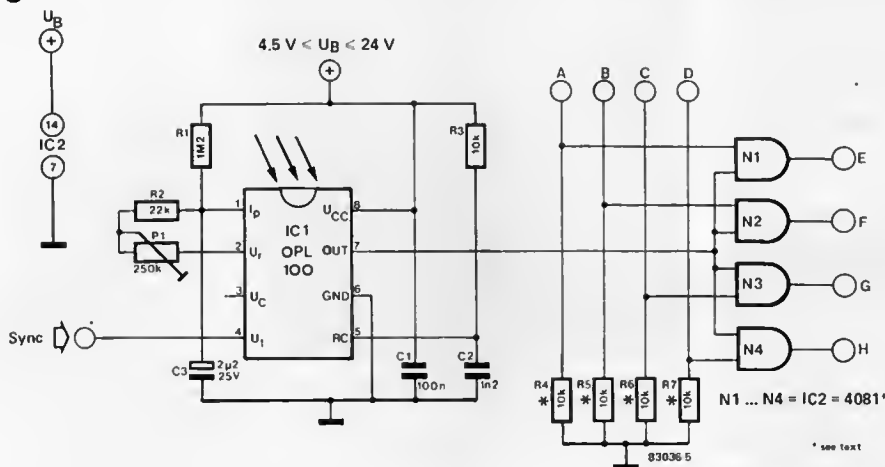

Figure 5. If the blank-input of the display driver cannot be used, it is still possible to create an automatic display-dimmer with some extra circuitry as shown here. The current for each digit is regulated via LEDs N1 to N4.

trigger pulse must then coincide with the start of the enable time of each digit and the frequency chosen for the output voltage of the ABC-sensor must be slightly lower than the trigger frequency (i.e. the multiplex frequency in this case).

Practical applications

The programmable darkroom timer

Figure 5 shows how the display brightness of the programmable darkroom timer (elsewhere in this issue) can be dimmed automatically, using the ABC-sensor. The circuit can be incorporated in the darkroom timer as follows. The ULN 2003 (IC2) is removed from the darkroom timer p.c.b. The circuit

of figure 5 and the ULN 2003 are then mounted on a separate (perforated) board; the connections shown in figure 6 are made between the circuit of figure 5 and the ULN 2003. The numbers of the terminals on the left and right in figure 6 correspond to those of the ULN 2003, so that the board can be inserted in the previous location of the ULN 2003 on the darkroom timer p.c.b. Once this has been done, the sync input of the added board is connected to pin 10 of IC1 (WD 55). Additionally, a 22 nF capacitor must be soldered between the collector and emitter of T1 (on the timer p.c.b.) to prevent interfering pulses on the supply line from upsetting the drive of the timebase input of the WD 55. The ABC-sensor must be arranged so that it

Table 1

U_{CC}	Supply voltage (pin 8)	4.5 ... 24 V
I_{CC}	Current consumption (pin 8)	25 mA max.
U_r	Reference voltage diode (pin 2)	0.4 ... 0.8 V
U_{ol}	Output voltage, low (pin 7)	0.4 V max.
U_{oh}	Output voltage, high (pin 7)	13 V min. (C type) 20 V min. (I type)
I_{ol}	Output current sink (pin 7)	-50 mA min.
I_{oh}	Output current source (pin 7)	20 mA min.
U_t	Trigger voltage (pin 4)	9 V max. (C type) 14 V max. (I type)
	Temperature range type OPL 100C	0 ... +70°C
	type OPL 100I	-20 ... +100°C

Note: the data apply to the type OPL 100C at $U_{CC} = 16$ V and type OPL 100I at $U_{CC} = 24$ V.

can 'see' the ambient light. The sensitivity can be adjusted with P1 to a particular ambient light intensity. R1 can be replaced by a resistor of a different value if the display is too bright or too dim in the dark; the greater the value of R1, the dimmer the display (in the dark). The value of R1 must not be less than 100 k.

The ABC-sensor and the MK 50398N

Various Elektor projects make use of the MK 50398N LSI counter, a large scale integration chip equipped with most of the primary functions for digital counters. Examples of applications of this device are, for example, the revolution counter (September 1981) and the shutter speed meter (October 1981). The ABC-sensor can be incorporated in these circuits quite simply. The basic circuit of figure 4 is used. Connect the output of the ABC-sensor to pin 16 of the MK 50398N, after removing the 120 pF capacitor from this point. The trigger input (sync) of the OPL 100 need not be used, because synchronisation is provided internally via pin 16 of the MK 50398N: the display driver is now synchronised by the ABC circuit! The positive supply voltage is applied to pin 4 of the OPL 100. Do not forget to connect the supply voltage (positive and ground) of the ABC circuit to the MK 50398N.

The 6502 housekeeper

The 6502 housekeeper (May 1982) can also be provided with automatic dimming. The circuit of figure 5 is used here. Once again, there is no need to use the trigger input of the OPL 100 and it should be connected to the supply voltage. The value of C2 must be increased to 12 nF, and resistors R4 to R7 can be omitted. A 74LS08 is used for N1 to N4 and three further gates must be added (connected in the same way as N1 to N4), since the 6502 housekeeper has a 7-digit readout: six 7-segment displays and a group of seven LEDs. The ULN 2003 (IC5) from

6

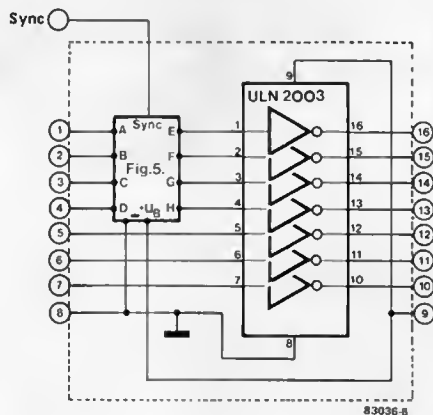

Figure 6. To equip the programmable darkroom timer or the 6502 housekeeper with an automatic display-dimmer, the ULN 2003 in those circuits can be mounted on a board which also accommodates the circuit shown in figure 5.

the 6502 housekeeper board is mounted, together with the ABC circuit (figure 5), on a small perforated board as shown in figure 6. The three extra gates are connected in series with inputs 5, 6 and 7 of the ULN 2003 (figure 6). The board can be fitted in the previous location of the ULN 2003 on the 6502 housekeeper p.c.b. The sync input of the ABC circuit should be connected to the positive supply.

We hope that these examples will be useful for practical application of the ABC-sensor. The specifications of the OPL 100 are listed in table 1 for readers wishing to design their own automatic display-dimmer circuits. M

Strictly speaking, this circuit is too good for a 'mere game', although it can certainly be a lot of fun. The reaction time is indicated to within one tenth of a millisecond on a 4-digit display, and the circuit can also evaluate the difference between the reaction times of two persons and indicate which one pressed his button first.

reaction tester

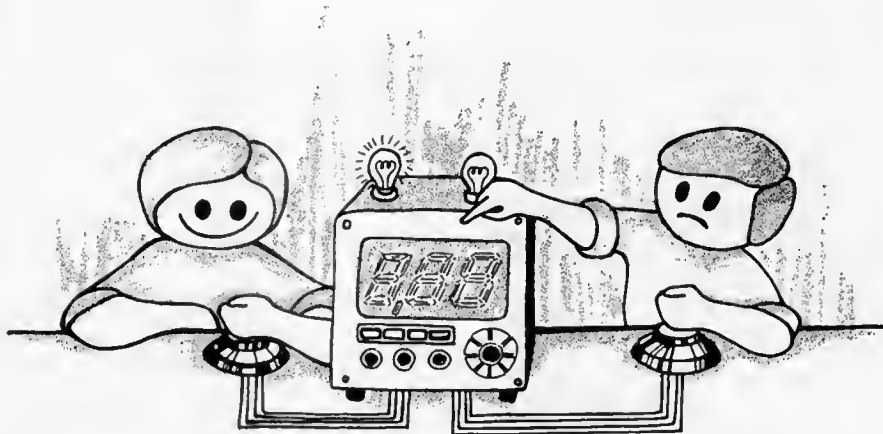

with variable
waiting time

Not only do reaction testers provide a lot of fun for all ages, they can also be used for more serious applications (testing a driver's reactions, say, or an athlete's reflexes). The unit is simple to operate: once the start button has been pressed there is a delay period until a LED lights up. The challenge then is to press a button as quickly as possible. The elapsed time (between the LED lighting up and the button being hit) is measured, and indicated as reaction time in milliseconds on a 4-digit display.

It is also possible for two people to compare their reaction times. In this mode, each person must press his own button when the LED lights up. The difference in elapsed time between the pressing of both buttons is then indicated on the display. Two further LEDs indicate which of the two contestants pressed his button first. Since only one LED can light up at any one time, home quizzes can be arranged on the principle of the TV version: the first one to press a button may reply first and gains a point.

The circuit

The circuit of the reaction tester contains well-known ICs. The timer IC4 is used as a monostable multivibrator with a period time that can be adjusted from 2 to 15 seconds by potentiometer P2. This provides a variable delay between the pressing of the start button and the lighting up of the LED. The monostable is triggered by start button S4. Gates N1...N4 form two set-reset flip-flops whose set inputs are connected to the

reaction buttons S1 and S2 of the two players; the reset inputs connected to the start button (S4). The set inputs are also connected to the positive supply via pull-up resistors R1 and R2. S1, S2 and the base of transistor T5 are connected to the output of monostable IC4. The output signal of IC4 causes transistor T5 to turn on and activate D3, the reaction LED.

When S4 is pressed the monostable multivibrator starts and the flip-flops are reset. The outputs of N1 and N3 are at logic 0. Additionally, IC5 (counter and display driver) is reset via N7 so that the display indicates '000.0'. During the delay time of the monostable, the output of IC4 (pin 3) is at logic 1 so that LED D3 remains dark and a logic 1 is present at S1 and S2. Pressing S1 and/or S2 during this delay time therefore has no effect. At the end of this period the output of IC4 goes to logic 0, causing D3 to light and buttons S1 and S2 are enabled. The circuit is now ready for the players' reactions!

The outputs of N1 and N3 are connected to the inputs of EXOR gate N9. This controls an astable multivibrator consisting of N8 and N10, which in turn delivers square-wave signals for the clock input of IC5. During the delay time of monostable IC4, the outputs of N1 and N3 were at logic 0 so that the square-wave generator was inhibited via N9. Now, as soon as one of the players presses his button and the corresponding flip-flop toggles, the output of N9 goes to logic 1 and the square-wave generator is enabled.

based on an idea
submitted by
L. van Boven

Light-sensitive devices are used in all kinds of fascinating applications: light-meters, cybernetic models, movement sensors — even optical communication links. We get the distinct impression, however, that many circuits are developed by means of enthusiastic trial-and-error — with little regard for basic principles. This can be great fun, admittedly: the result tends to perform in unexpectedly spectacular ways! We don't really like printing 'theoretical' or 'educational' articles. In this case, however, some background information seems long overdue. Furthermore, we have two practical circuits to offer: a light gate and a distance meter.

O, IC!

using photodiodes



A photodiode can be described as a 'light-controlled current source', or as a 'light-to-current converter', if you prefer. When light falls on the diode, this results in a tiny (proportional) current, as shown in figure 1a. This current flows from cathode to anode. In theory, the anode of an ideal unconnected diode would become more and more positive, until the voltage across it caused the diode to conduct. A current would then flow in the opposite direction, from anode to cathode; in the equilibrium state, the two currents would cancel out and a voltage would appear across the diode. This is all grossly oversimplified theory, of course: in practice, there will always be some kind of leakage resistance across the diode: this is shown as R_L in figure 1b. This load resistance is partly internal; any external load is connected in parallel. All in all, the photocurrent from cathode to anode (which is proportional to incident light) is

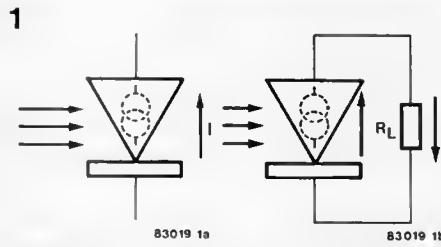

Figure 1. A photodiode can be considered as a current source that is controlled by the light that falls on it. The photocurrent flows from cathode to anode.

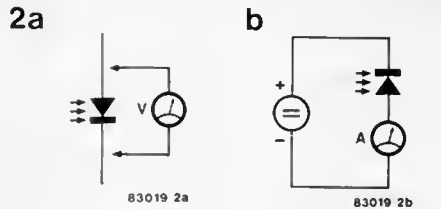

Figure 2. A photodiode can be used in two ways. The voltage across the diode can be measured directly (2a); alternatively, a reverse bias is applied and the current through the diode is measured. These two basic modes are referred to as the photo-voltaic mode and the photocurrent mode, respectively.

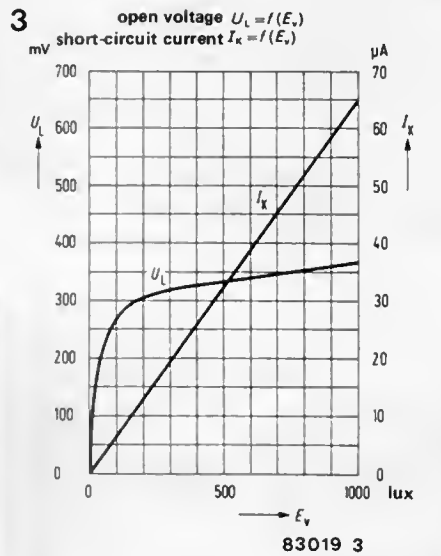

Figure 3. Curve U_L gives the off-load voltage as a function of light intensity. Curve I_k depicts the relationship between short-circuit current and light intensity. (All the curves in figures 3 to 6 relate to the Siemens BPW 34.)

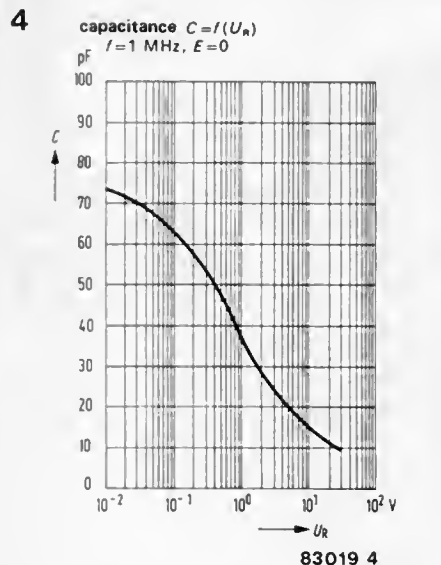

Figure 4. The capacitance of a photodiode reduces considerably as the reverse bias (U_R) is increased.

balanced by three other current flows from anode to cathode: a 'normal diode mode' current, an internal leakage current and the current through the external circuit. The latter current is the one that is to be detected or even measured by the rest of the circuit. Given this knowledge, there are two basic circuit configurations to choose from: the 'photovoltaic mode' and the 'photocurrent mode'.

Photovoltaic mode

In this mode, a photodiode is used as a light-controlled voltage source (figure 2a). Some kind of voltage measuring circuit is used to evaluate the voltage that appears across the diode. Depending on the impedance of the measurement circuit, the relationship between the incident light and the measured voltage can be anything from linear to logarithmic!

The relationship will be almost logarithmic if an ideal voltmeter is used. By 'ideal', we mean one with an extremely high internal resistance – in the order of 100 Gigaohms. This is rarely the case. On the other hand, a fairly linear characteristic is obtained by using a 'voltmeter' that is virtually a short circuit. Since this extreme case is also impractical (a short circuit tends to reduce the voltage to point-zero-zero-zero...), the actual measuring characteristic will be some ill-defined non-linear curve.

In practice, the photovoltaic mode is not so useful for measurements. In general: any application requiring a well-defined relationship between light and output is likely to go wrong if this system is used. It can only work if you go to extremes: if the load is more than 10 MΩ, the characteristic will be reasonably logarithmic; below a few ohms, it could be linear. Anything in between is only useful for detecting light.

Photocurrent mode

In this mode, the photodiode is reverse-biased as shown in figure 2b, and the current is measured. The reason is immediately apparent from figure 3: the semi-logarithmic curve corresponds to a voltage measurement, and the straight line shows the relationship between the (short circuit) current through the diode and the incident light. The actual values shown in this plot (and in figures 4...6) apply to the Siemens BPW 34, but the same principle applies to all photodiodes. A further advantage of this system is apparent from figure 4: the higher the reverse bias, the lower the diode capacitance. This improves the response, extending the sensitivity towards higher frequencies.

Given all these obvious advantages, why are photodiodes ever used any other way? We mustn't forget that fundamental law: 'Conservation of Misery'. If one characteristic improves, something else must suffer. In this case, the main disadvantages are 'flicker noise' (caused by the high reverse bias) and the influence of the diode's leakage current, which increases rapidly with temperature as shown in figure 5. The latter effect becomes increasingly important as the reverse bias is increased: figure 6 shows the relationship.

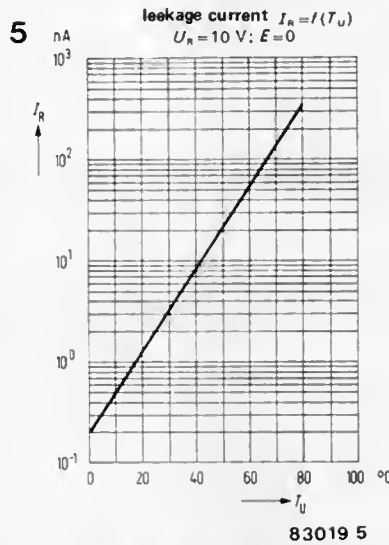

Figure 5. Leakage current (I_R) as a function of temperature.

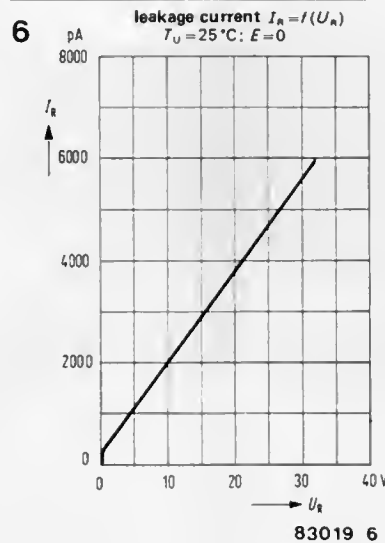

Figure 6. Leakage current (I_R) as a function of reverse bias (U_R).

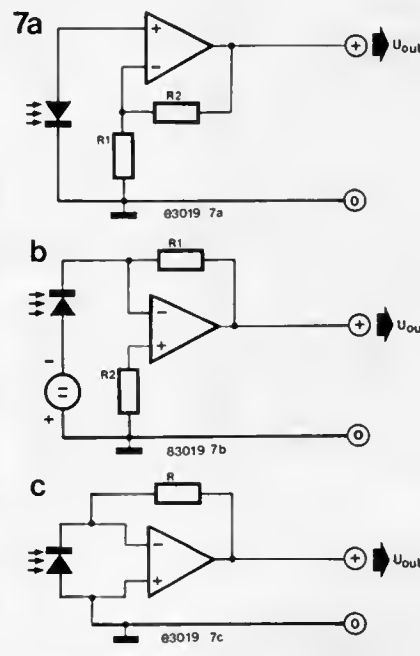

Figure 7. Three basic circuits:
a. diode in the photovoltaic mode;
b. example of the photocurrent mode;
c. photocurrent mode with zero volts reverse bias.

8

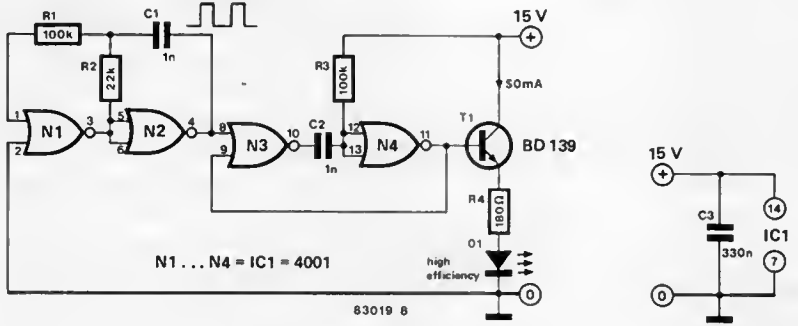

Figure 8. The light gate transmitter. A (high efficiency) LED is driven by a 10-20 kHz square-wave.

9

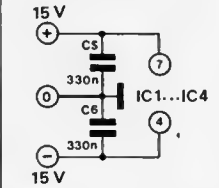
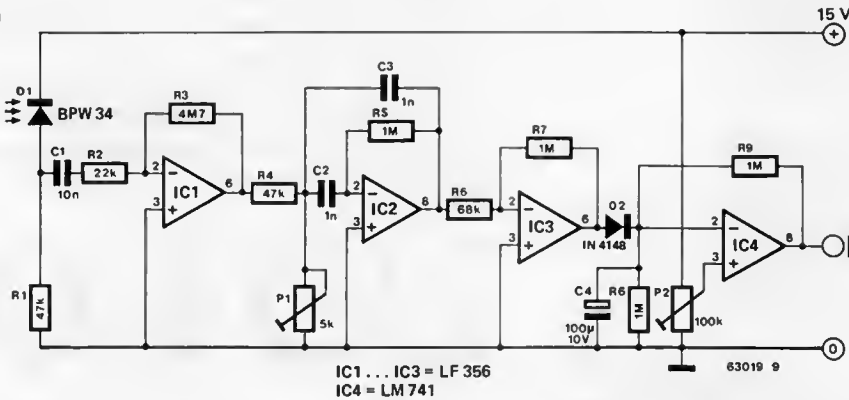

Figure 9. The light gate receiver consists of a photodiode and a few opamps.

In electronics, reaching an ideal compromise is the art. Say that you intend to use photodiodes for a communication system: you need a high reverse bias for fast response, and the trade-off is that the linearity must suffer. Alternatively, you want to design a light-meter: linearity is vital, so you opt for a low bias and a slow response.

Basic circuits

Three basic circuit configurations are shown in figure 7. To obtain a reasonably close approximation of a logarithmic characteristic, the diode must be used in the voltaic mode. This can be achieved by using a FET opamp as shown in figure 7a: the extremely high input impedance of the opamp forms a negligible load across the diode.

For a linear characteristic, the diode must be used in the current source mode. In the virtual earth circuit shown in figure 7b, the load impedance across the diode is equal to $R1$ divided by the (extremely high) gain of the opamp. This works out at a very low value indeed! As mentioned above, the reverse-bias that is applied in this circuit helps to increase the response time. However, it does cause a deviation from the linear characteristic. If this is unacceptable and if a fast response is not required, the bias voltage source can be omitted (figure 7c).

A light gate

Let's put theory into practice, and design a 'light gate'. This must consist of an optical 'transmitter' and a 'receiver', lined up in such a way that any person passing between them will break the beam. The transmitter is

shown in figure 8. It works as a kind of high-frequency power flasher. N1 and N2 form a multivibrator that oscillates in the region of 10...20 kHz; N3 and N4 convert the squarewave into a series of short positive-going pulses. These are fed to T1, causing the LED (D1) to flash. A normal LED can be used, but better results are obtained with a high-efficiency type. If you really want to get the maximum range, the LED can be mounted in a reflector. The total current consumption of this circuit is approximately 50 mA.

10

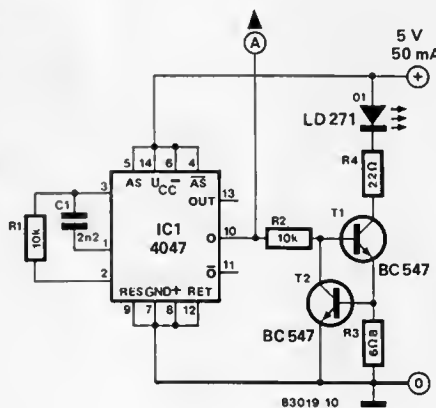

Figure 10. The distance meter transmitter. As before, a squarewave is applied to the LED. Since the distance is to be calculated from the reflected light intensity, the LED current is held constant by means of a current source (T1, T2).

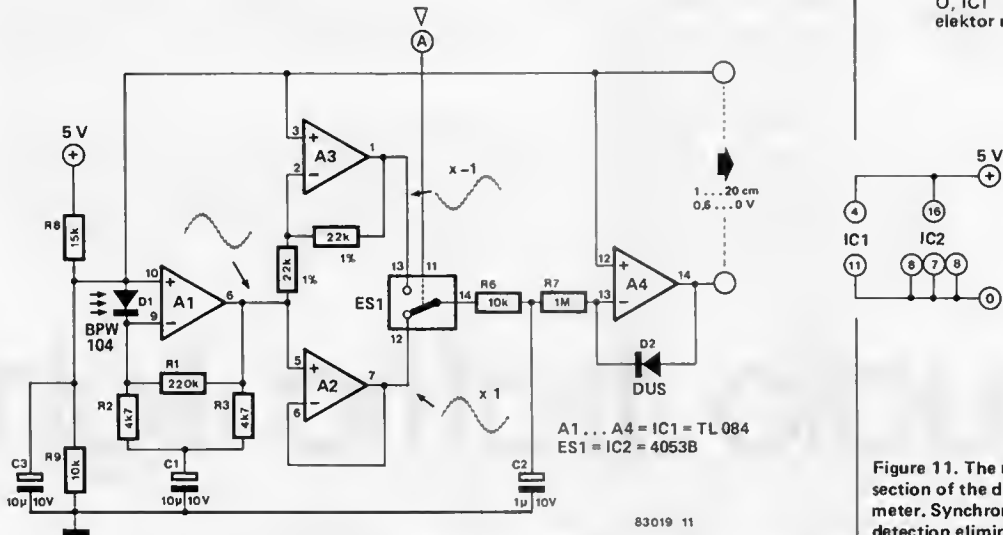

Figure 11. The receiver section of the distance meter. Synchronous detection eliminates low-frequency interference.

In this application, the light receiver must be designed for maximum sensitivity and high frequency response; linearity is not so important. For this reason, the photodiode is used in the current mode with a high reverse bias (figure 9). The signal from the diode is amplified (IC1), applied to a band-pass filter (IC2), then amplified again (IC3), rectified and applied to a trigger circuit (IC4). Normally, the output from IC4 will be at -15 V; when the light beam is broken, this output will swing up to +15 V.

The alignment procedure is quite straightforward. Start with the LED and photodiode within a few inches of each other, and adjust P1 for maximum output from IC2. A word of warning: the filter can start to oscillate if P1 is set to zero (wiper to ground). If no clear maximum can be obtained, the transmitter frequency is probably outside the range of the filter. This can be corrected by selecting a different value for C1 in figure 8.

There should now be a DC voltage across C4, which drops to zero when the light beam is interrupted; P2 is adjusted so that the output of IC4 switches cleanly. Separate power supplies should be used for the two circuits: the high gain involved could easily lead to oscillation with a common supply. The best way to line up the receiver and transmitter is to connect an oscilloscope to the output of IC3, or a voltmeter across C4. Then aim the transmitter for maximum received signal.

Distance meter

This circuit is more in the nature of a design idea: it can be modified and perfected according to the intended application. Originally, it was intended as a ranging device for a cybernetic model: it can measure distances of up to 6 or 8 inches with reasonable accuracy.

The basic idea is to mount a light transmitter and a receiver side-by-side; any light reflected from a nearby object is measured, and the intensity serves as an indication of the distance.



The distance meter prototype. Visible from right to left are the transmitter LED with its reflector, the photodiode for the receiver and part of the associated electronics.

The transmitter (figure 10) is a simple 10 kHz oscillator with a duty-cycle of precisely 50%, which drives the LED via a current source to ensure that the light output is constant. The receiver (figure 11) is only slightly more complicated.

For obvious reasons (linearity!), the photodiode is used in the current mode without reverse bias - as in figure 7c. Opamp A1 provides gain, and the feedback network serves to reduce the low-frequency content of the signal: mains hum, caused by incandescent or even fluorescent ambient lighting! Merely filtering the signal is insufficient, however. In our prototype, we added a synchronous demodulator: A2, A3 and S1. This bit of high-frequency jargon stands for a simple principle. The output from A2 is identical to the output from A1; the output from A3 is the same signal in antiphase, since A3 works as an inverter. A CMOS switch (S1, a 4053) alternates rapidly between these two signals; it is controlled by the transmitter, so that it switches in synchronism with the desired input signal. For unwanted signals, however, it will be out of sync. The result is that the phase and antiphase signals tend to cancel out.

The 'clean' demodulated signal from S1 is passed through a low-pass filter (R6, C2). Finally, the circuit around A4 is designed to convert the basic square-law relationship between distance and signal-strength into a more linear characteristic.

What has a traffic light got to do with audio? Nothing, really, but this particular circuit drives three LEDs; the colours are red, orange (amber!) and green, and they are mounted in a vertical line in this order. When we saw the prototype, it reminded us of . . .

Yes. Well. This circuit does have a rather different function. The LEDs indicate the level of the output signal from a preamplifier, allowing one to judge the quality and quantity of the signal being fed to the power amplifier. This makes the circuit a useful accessory for the Prelude preamplifier in the XL range, as well as for other preamplifiers.

audio traffic light

visual level
monitor for
preamplifiers

For the level indication on the Prelude preamplifier, we decided to depart from the usual VU meters and LED bar indicators. These accessories on a preamplifier usually provide little in the way of information and merely swing nicely in rhythm with the music – although there are of course exceptions to the rule. On the other hand the audio traffic light, as we have named the circuit, uses only three LEDs. Sufficient for this application.

The three LEDs perform the following functions. The green LED lights when the supply voltage is on. In other words, it indicates that the preamplifier is switched on. The amber (or yellow) LED goes on when a signal is present at the output of the preamplifier. Thus it is possible to see at a glance whether a signal is being applied to the power amplifier (or headphones) by the preamplifier. Finally, the red LED indicates when the output signal from the preamplifier exceeds a preset value. This value can be chosen so that the red LED goes on if the power amplifier is being overdriven. However, the red LED can also be made to light up when a certain audio level is exceeded (just below the angry-neighbour or wake-the-children level, say). In this case a sound level meter could be used to adjust the circuit to a particular audio level, but it is more practical to do the job by ear.

As you can see, three LEDs are sufficient to provide all necessary information regarding the output signal from the preamplifier.

Circuit diagram

The circuit for driving the LEDs can be seen in figure 1. The green LED, D7, is connected to the positive supply voltage via limiting resistor R41. That is simple enough. For the other two LEDs, a signal detector is needed to monitor the level of the output signal from the preamplifier, and to light up one of the two LEDs as a result. The LEDs must give a clear indication, even for short transients. This signal detection is separately arranged for each LED. The circuitry associated with A1, A2 and MMV1

is for the red LED, and the section around A3, A4 and MMV2 is for the amber LED. The left-channel output signal of the preamplifier is fed to presets P10 and P11 and the right-channel output signal to P12 and P13.

First, the control circuit for the amber LED. P10 and P12 are each connected to the non-inverting input of an operational amplifier (A3 and A4), via a capacitor. Each operational amplifier is configured as an a.c. voltage amplifier with high amplification (2200-times for A3 and A4, 220-times for A1 and A2). The output signals of A3 and A4 are rectified by diodes D3 and D4 respectively. The cathodes of the two diodes are connected to the trigger input of a retriggerable monostable multivibrator MMV2. The Q_B output of MMV2 drives the amber LED D6 via R40 and T14. The MMV causes the LED to light up for 0.5 s if the output signal of D3 and/or D4 becomes greater than approximately 7 V. The 'sensitivity' of the amber LED can be adjusted separately for each channel using the potentiometers.

The circuit for the red LED is almost identical to that for the amber LED. The only difference is that operational amplifiers A1 and A2 are set to a lower gain, because the 'input sensitivity' of the red LED need not be as great as that of the amber LED. That's the circuit; we shall now examine a few details. In each detector circuit, the left and right input signals are amplified separately to ensure that the LED does not fail to light if the left and right signals should appear in phase-opposition, for example. The circuit therefore always responds to the greater of the two input signals. The gain of the operational amplifiers can be modified by changing one resistance value for each device (R24 for A1, R27 for A2, R30 for A3 and R33 for A4); the higher the resistance, the lower the amplification.

The minimum on-time of the amber LED is determined by R38 and C19; R37 and C18 correspond to the red LED. This time can be extended by increasing the value of the capacitor. You may also have noticed

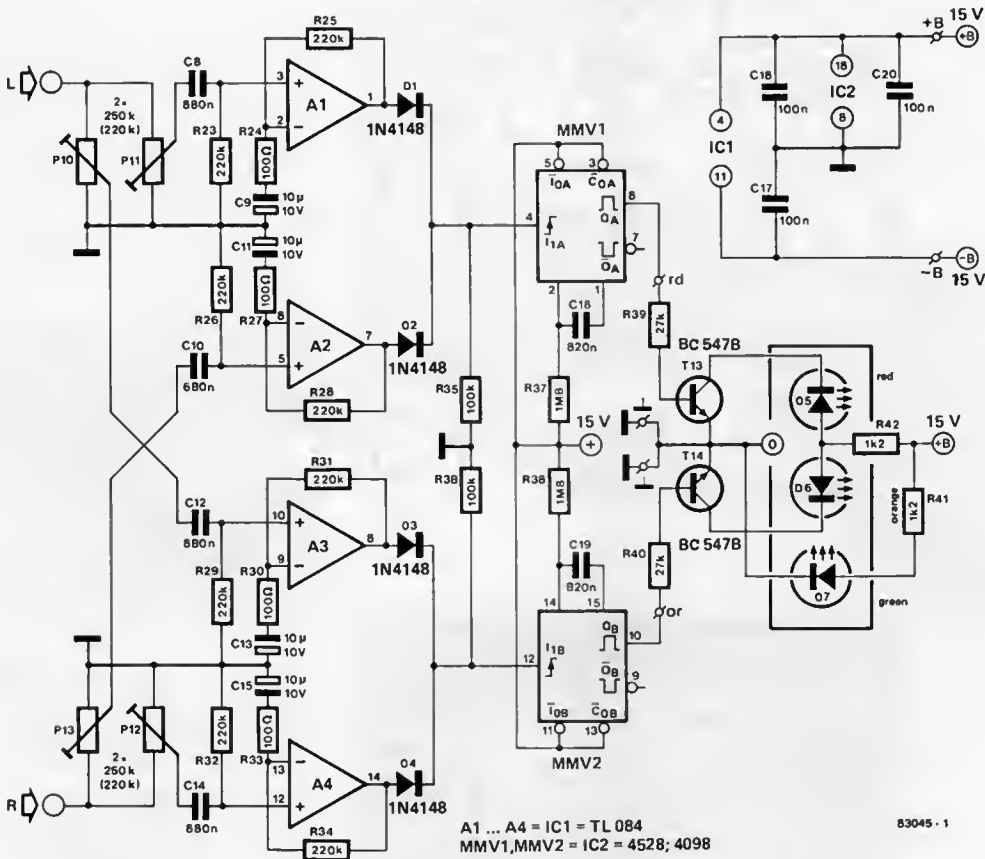

that D5 and D6 share the same limiting resistor. This has been done deliberately. The voltage drop over a red LED is slightly lower than that over an amber LED. (Don't use a high-efficiency LED; these have a higher voltage drop!) As a result, when T13 and T14 both conduct at the same time, only the red LED will light. The amber LED will go off on account of the difference in voltage drop.

Construction

The printed circuit board of figure 2 can accept all the components except for R39... R42, D5, D6, D7, T13 and T14. These components are accommodated on the bus p.c.b. of the Prelude. If the audio traffic light is to be used in combination with the Prelude there is no problem. These components are simply mounted on the bus p.c.b. and the board for the audio traffic light is connected to the bus p.c.b. by means of wire links. The copper track side of the audio traffic light p.c.b. must face out towards the outer (right-hand)

edge.

If the audio traffic light is to be used with a preamplifier other than the Prelude, the components mentioned above will have to be mounted elsewhere. This should not present any problems, since only a few components are involved. Furthermore, the LEDs can be mounted on the front panel, which only leaves the four resistors and two transistors. The inputs of the circuit are connected to the outputs of the preamplifier.

The circuit requires a symmetrical power supply of + and - 12... 15 V which can provide at least 50 mA. This is included in the Prelude, but in other applications a small power supply can be built for the audio traffic light, consisting of a 2 x 9 V/100 mA transformer, a bridge rectifier and two electrolytic capacitors of 1000 μ F/25 V. A stabilized supply is not required.

Adjustment for the amber LED is simple. Set P10 and P12 to zero; turn on the music and adjust the volume control of the preamplifier so that the signal is heard at a low level. Then turn up P10 and P12 just far

Figure 1. The circuit of the signalling circuit; three LEDs provide information on the output signal.

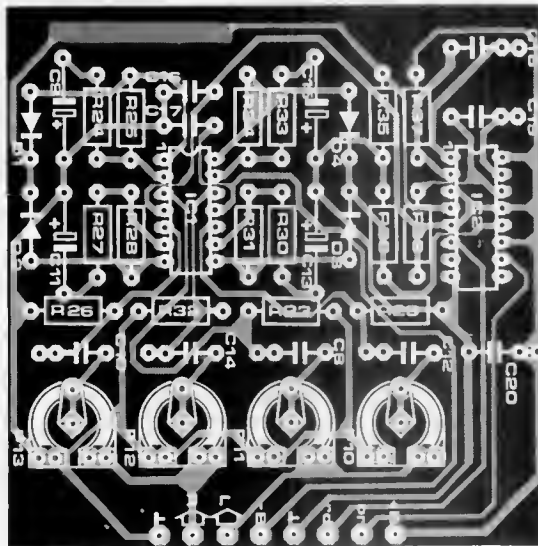
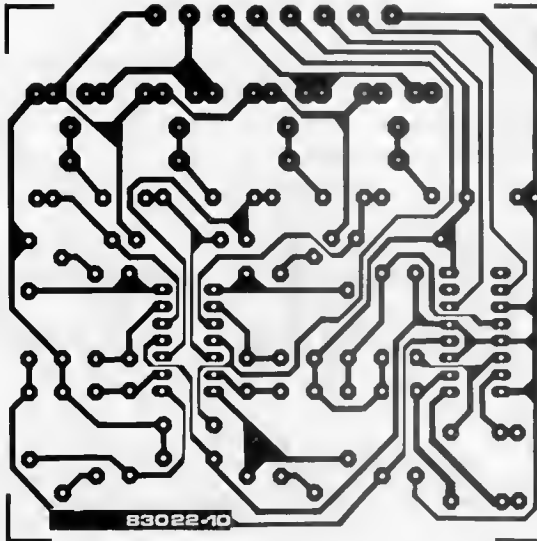

Parts list

Resistors:

R23, R25, R26, R28, R29,
R31, R32, R34 = 220 k
R24, R27 = 1 k
R30, R33 = 100 Ω
R35, R36 = 100 k
R37, R38 = 1M8
R39*, R40* = 27 k
R41*, R42* = 1k2
P10 . . . P13 = 250 k
presets

Capacitors:

C8, C10, C12, C14 = 680 n
C9, C11, C13, C15 = 10 μ /
10 V
C16, C17, C20 = 100 n
C18, C19 = 820 n

Semiconductors:

D1 . . . D4 = 1N4148
D5* = red LED
D6* = orange LED
D7* = green LED
T13*, T14* = BC 547B
IC1 = TL 084
IC2 = 4098, 4528

Note: Components marked
* are mounted on
the bus p.c. board

Figure 2. Printed circuit board for the audio traffic light. The circuitry associated with the LEDs (R39 . . . R42, D5 . . . D7, T13 and T14) is not situated on this board but on the bus p.c.b. of the Prelude.

enough for LED D6 to light. This must be done separately for each channel, with the other channel disconnected from the pre-amplifier.

The adjustment of P11 and P13 depends on the indication that one wishes to obtain from the red LED. If it is to light up when the power amplifier starts clipping, an oscilloscope and a pair of hefty load resistors are needed. Applying a 1 kHz sinusoidal signal via the preamplifier to the output stage, the power amplifier is driven to the point at which it starts clipping (the amplifier must have a load corresponding to the nominal impedance of the proper loud-

speakers; for example, 8 Ω resistors). This adjustment must also be performed separately for each channel. This setting is not particularly useful, however, because the red LED should never light up under normal circumstances.

It is better to adjust the potentiometers for the red LED so that it lights up at a particular sound level in the room; the LED will then indicate that the amplifier is turned up too loud or that your neighbours are reaching their tolerance threshold. It is advisable not to establish this setting by trial and error - better results can be obtained after prior consultation with the neighbours. \blacksquare

Pico hook

As components in the micro-electronics world become smaller, so must the accessories to be used with them. One such accessory is the new EZ Hook test probe, which measures barely 1" in length. Introduced into the UK by I & J Products Ltd., the Pico Hook is the result of market research amongst users of the EZ Hook range. Because of its diminutive size and weight, the Pico Hook is only available prewired (with a choice of 28 AWG or Teflon wire); wiring up the head would be too tedious for most engineers' fingers.



However, the famous 'hypodermic' action of all EZ Hooks continues in the moulded nylon body of the Pico Hook, with the hook and spring loading being manufactured as always of gold-plated beryllium copper and stainless steel respectively. The Pico Hook is available in ten colour-codings (as in the lead), which can be supplied attached to lead only, or connected to .025 sq. socket, .025 pin or a second Pico Hook.

I & J Products Ltd.,
7a Christchurch Road,
Ringwood,
Hants.
Telephone: 04254.79974.

(2517 M)

Improved large alphanumeric display

The Industrial Products Division of Industrial Electronic Engineers, Inc., (IEE), has made it easier to use their Argus 256-character flat panel alphanumeric DC plasma display module. This model is engineered with 0.26" (6.5 mm) high



(2565 M)

characters, for the user who requires a multi-line display which is easily legible from distances up to fifteen feet. The module, model number 3101-08-256N, incorporates Schmitt-trigger data input circuitry, allowing the display to operate reliably in high EMI environments. Power requirements are now only +5 V and +150 V. (Previously, this model required -12 V as well.)

Data is displayed in a 5 x 7 dot matrix with a selectable cursor/underbar. Up to 8 lines of 32 characters per line can be displayed. Data input is TTL level, 6-bit parallel ASCII, at rates up to 120 kHz. Character sets available include: English ASCII-7 (standard) and General European, German, Scandinavian and Spanish ECMA fonts.

IEE, Industrial Products Division,
7740 Lemoona Avenue,
Van Nuys, CA, 91405,
(213) 787-0311, ext. 233.

Minicase

The new Boston hand-held instrument case range from West Hyde is moulded from black ABS, although other colours are available for large orders. The styling, has resulted in an extremely attractive as well as functional case, is ideal for all applications involving hand-held digital readouts such as thermometers and tachometers.



The cases feature a separate battery compartment and an optional thumb-button which could be used to operate on-off or range-change switches for example. A choice of display aperture sizes allows for a variety of digital displays to be fitted.

The Boston is available ex-stock from West Hyde from whom a data sheet can also be obtained giving further details of this handy sized case.

West Hyde Developments Ltd.
Unit 9 Park Street Industrial Estate,
Aylesbury,
Bucks. HP 20 1ET.
Telephone: 0296.20441

Miniature high value inductors

Toko's 5T series is a magnetically screened inductor (range 50 μ H to 5 mH) designed for bias oscillator applications in micro cassette recorders, floppy disk drives, and all other applications requiring a miniature precision inductor, with facilities for primary taps, and secondary windings. The maximum height above the PCB face is 9 mm, with a square base of 5.5 mm each side.

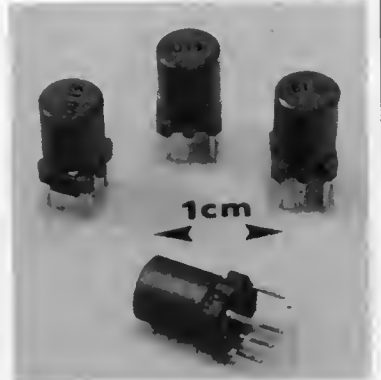

(2598 M)

A range based on 80 kHz and 50 kHz bias oscillators will be held by Ambit - although the coil series is primarily intended for custom design applications.

Ambit International,
200, North Service Road,
Brentwood,
Essex CM14 4SG.

(2600 M)

The world's lowest profile adjustable VHF coil

The HF/VHF counterpart of the new 5U series is Toko's 5UN. This is an open construction coil with ferrite adjuster, designed for use in the range 20-200 MHz, with a maximum inductance of 0.35 μ H and a Q of over 90 and 100 MHz.

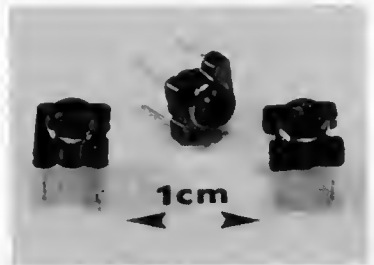

The height above the PCB is only 3.5 mm, (the base is 5.5 mm square) making the coil ideally suited for use in such equipment as personal radios, pagers, cordless telephones etc.

Ambit International,
200, North Service Road,
Brentwood,
Essex CM14 4SG.

(2599 M)

The magazine with a different approach to micro's.

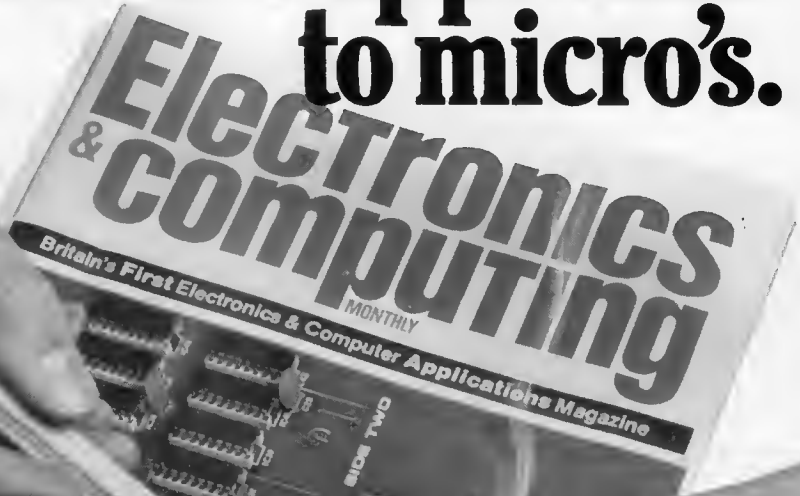

Electronics and Computing Monthly looks at a computer as the beginning of something interesting rather than an end in itself.

We thought that using a micro to drive something other than a TV screen could open up fascinating possibilities.

A few simple circuits, used as building blocks, can stretch your computer, your imagination and your fun, a long way.

If you understand the basics of digital electronics, you'll appreciate the fun you can

have by linking logic circuits to your micro.

If you don't, then read our new series which starts this month and explains digital electronic circuits from basics. Also this month, we show you how to build an infra-red remote controller for your micro.

That's what Electronics and Computing is all about – giving you ideas for new

applications, and giving you the software to expand your micro. Project by project we show you how to add another dimension to your computer.

For example, in this month's issue we explain dialogue programming using the PILOT system – what it is and how it works.

And inside is enough information to build your own hi-res graphics computer.

All you need is a hot soldering iron and a cool 75p.

WHERE ELECTRONICS AND COMPUTING INTERFACE.

At your newsagent from Feb 12th

elektor BUYERS GUIDE

AMBIT international
200 North Service Road, Brentwood, Essex
 TELEPHONE (STD 0277) 230909 TELEX 995194 AMBIT G POSTCODE CM14 4SG

C.T.S. 20 CHATHAM STREET,
 RAMSGATE,
 KENT CT11 7PP.
 Tel. Thanet 54072

We stock a vast range of components for the amateur and professional engineer

ANNLEY ELECTRO
 190 Bedminster Down Road
 Bedminster Down, Bristol BS13 7AF
 Tel: 0272 632622
 Open: Mon-Sat 9 am-6.30 pm

DOUGLAS ELECTRONIC COMPONENTS
 90 Wellington Street, Stockport, Cheshire. SK1 3AQ

BOOKS · CROSSOVERS · CABLE · COMPONENTS · CONNECTORS · DECKS FUSES · HEADPHONES · LEADS MICROPHONES · MULTIMETERS · PROJECT BOXES · SOLDERING IRONS SPEAKERS · STYLII & CARTRIDGES TOOLS · VEROBORD ETC.

REPAIR SERVICE

Tel: 061-480 8971

Lightning Electronic Components
 18 Victoria Road, Tamworth, Staffs. B79 7HR Tel. 0827 65767

*A huge selection of electronic components available to callers at our showroom or through our express postal service.
 Retail and trade supplied.*

ELECTRO SUPPLIES

WHOLESALE & TRADE COUNTER
 BOWNESS MILL · SHAWCLOUGH RD.
 WATERFOOT · ROSSENDALE
 LANCS
 TEL: ROSSENDALE 215556

RETAIL SHOP
 6A, TODD STREET
 MANCHESTER
 (Next to Victoria Station)
 TEL: 061-834 1185

BRADLEY MARSHALL LTD
 SPECIALIST ELECTRONIC COMPONENT DISTRIBUTORS
 325 Edgware Road, London W2 1BN.
 Tel. 01 723 4242
 Telex 295441
 Stockists of Texas, National, Thomson (CSF), Siemens, Crimson Elektrik, Thendar, RCA, Bahco Tools Ltd., and many more.

ELECTROVALUE

Head Office, Mail Order Dept and Shop
 28 K St, Judea Road, Englefield Green, Egham, Surrey TW20 0HS Telephone Egham (STD 0784) London 871 33603; Telex 264475
 Also in Manchester for personal shoppers at...
 680 Burnage Lane, Burnage, Manchester M19 1NA
 Telephone 061-432 4946
 Computing Shop North...
 700 Burnage Lane, Manchester Telephone 061-431 4866

CARDIGAN ELECTRONICS
 Chancery Lane, Cardigan,
 Tel: Cardigan (0239) 614483
 Open: Mon-Sat 10am-5pm. Closed Wed.
 Electronic components & BBC computer stockist.

EMOS
 High March, Daventry, Northants NN11 4HQ.
 Tel: 03272 5523 Telex: 311245 GRENEL G.

Casey Brothers
 WHOLESALE ELECTRICAL SUPPLIES
 INDUSTRIAL AND DOMESTIC
 Palladium House Boundary Road St Helens Merseyside WA10 2LL
 Telephone 0744 27873 or 20030

GARLAND BROS. LTD
 Electronic Components Specialists
GB
 Chesham House, Deptford Broadway, London, SE8 4QN
 Telephone: 01-692 4412

CRICKLEWOOD ELECTRONICS LTD.
 STOCKING PARTS OTHER STORES CANNOT REACH!
 40 CRICKLEWOOD BROADWAY, LONDON NW2 3ET.
 TEL: 01-452 0161 Telex: 914977

ELECTRONIC COMPONENTS & SEMICONDUCTOR SPECIALISTS
 TRADING IN SUCCESSION TO
 A. MARSHALL (LONDON) LTD.



L.F. HANNEY
 77 Lower Bristol Road, Bath, Avon.
 Tel. 0225-24811
 Your electronic component specialist for Avon, Wilts. & Somerset.
 Closed Thursdays

CRYSTAL ELECTRONICS
 209 Union Street, Torquay, Devon.
 Tel. Torquay 22699

HENRY'S 404 Edgware Road,
 London W2 1ED.
 Tel. 01 723 1008 -
 Telex 262284 -
 Monoref 1400

TEST EQUIPMENT & COMPONENTS
 Transistors, ICs, Capacitors, Semi-conductor, Resistors, Relays, Potentiometers, Presets, Trimmers, Rectifiers, Zeners, SCR, Triacs, etc.

elektor BUYERS GUIDE

TRY US FIRST
for all
ELECTRONIC COMPONENTS AND GENERAL
ELECTRICAL SUNDRIES

J.T.FILMER

82 DARTFORD ROAD DARTFORD
Telephone: 24057

PROGRESSIVE RADIO

'THE ELECTRONICS SPECIALISTS'

Aerials/Components/Ham & CB Radio — a fully comprehensive range.

93 Dale Street, Liverpool L2 2JD.

Tel. 051 236 0982

Also at 47 Whitechapel, Liverpool.

Tel. 051 236 5489

TECHNOMATIC LTD

MAIL ORDERS TO: 17 BURNLEY ROAD, LONDON NW10 1ED
SHOPS AT: 17 BURNLEY ROAD, LONDON NW10
(Tel: 01-452 1500, 01-450 6597, Telex: 922800)
305 EDWARE ROAD, LONDON W2



Detailed Price List on request...

Stock items are normally by return of post.



SERVIO RADIO

established
1947

156 Merton Road,
South Wimbledon,
London SW19 1EG.
Tel. 01 542 6525

EXTENSIVE RANGE
OF COMPONENTS
AND BOOKS.

HEMMINGS

16 Brand Street,
Hitchin, Herts.
SG5 1JE.
Tel. 0462 33031

Shop opening hours:

Mon to Fri
9am to 5.30pm
Sat 9am to 5pm
Wed closed

ELECTRONICS

Electronic Components & Microcomputers

SHUDEHILL Supply Company Ltd.

53 Shudehill, Manchester M4 4AW.

We stock a wide range of components

Mail Order enquiries welcomed.

Tel. 061 834 1449



Electronic Components Distributors
85 WEST REGENT STREET
GLASGOW G2 2DD
TELEPHONE 041 332 4133-4-5

Judge us by the company we keep —
Siemens, Texas, National, Mullard, Leader, ITT,
Global Specialities, Piher, Sinclair/Thandar, Greenwood,
Arrow, Antex, Sifam, Verob, Motorola

SPECTRON ELECTRONICS LTD. MANCHESTER

ELECTRONIC
COMPONENTS,
TEST EQUIPMENT, ELEKTOR
PCBS AND BOOKS TECHNICAL BOOKS.

7 OLDFIELD RD SALFORD TEL: 061 834 4583

MAPLIN

ELECTRONIC SUPPLIES LTD

P.O. Box 3, Rayleigh, Essex SS6 8LR. Telephone: Southend (0702) 552911/554155
Shops at:
159-161 King Street, Hammersmith, London W6 Tel: (01) 748 0926
Lynthon Square, Perry Barr, Birmingham. Telephone: (021) 356 7292
284 London Road, Westcliff-on-Sea, Essex. Tel: (0702) 554000
All shops closed Mondays

Please mention

elektor

when ordering goods or requesting
information from advertisers.

P.A.T.H. Electronic Services

369, ALUM ROCK ROAD
BIRMINGHAM B8 3DR
TEL: 021-327-2339

A vast choice of components for the electronics
hobbyist and the professional.
Callers most welcome.

**SPECIALIST REPAIR, DESIGN & CONSULTANCY
FOR ALL TYPES OF ANALOG & DIGITAL SYSTEMS.**
20 A EDWARD STREET, BIRMINGHAM B1 2RX
Tel: 021-236 5036

peats
the world of electronics
Tel. 749973/4

FOR COMPUTERS, ELECTRONIC
AND VIDEO GAMES, COMPONENTS.
(ATARI SPECIALISTS)

25/26 Parnel Street,
Dublin,
Republic of Ireland

STEVE'S ELECTRONICS SUPPLY COMPANY

45 Castle Arcade, Cardiff CF1 2BU, Wales.
Tel. 0222 41905

T. POWELL

311 EDWARE ROAD, LONDON W2. TELEPHONE 01 723 9246

Shop hours: Mon. to Sat. 9a.m. — 6p.m.

TK ELECTRONICS^{UK}

11 Boston Road, London W7 3SJ

Just phone 01 5-6-7 8-9-10
24 hour answering service

KITS, RESISTORS, SEMI-CONDUCTORS, CAPACITORS,
LINEAR & DIGITAL ICs, HARDWARE, TOOLS, BOOKS.

ACCESS and BARCLAYCARD welcome

Cheap Imitations?



Microdocteur

is an alternative to AUTOMATIC TEST EQUIPMENT which can be very expensive. MICRODOCTEUR is perfectly adequate for diagnosing faults in microprocessor boards or computers in the REPAIR SHOP or on the PRODUCTION LINE. Reports are PRINTED on the integral thermal printer. Tests supported are CHECKSUM, RAMTEST, WAIT, READ, WRITE, I/O READ, I/O WRITE, DUMP IN HEX, DUMP IN ASCII, TEST DATA LINES (for shorts between data, address and rails), SEARCH (for two specified bytes), MAP (print a memory map of RDM, RAM, I/O and EMPTY SPACE). Supports both multiplexed and non multiplexed address/data. Standard software will also DISASSEMBLE in Z80 mnemonics - other disassemblers cost extra. Programs for board testing can be written in MINUTES - and retained for MONTHS even if the power is switched off (CMOS RAM is backed-up with rechargeable battery). Capacity is 15 different programs of 12 tests each. Included are two PROBE CONFIGURATION CARDS (One Z80, other uncommitted), PRDRE with 24 inch cable and 40-pin DIL plug - and POWER SUPPLY. Extras available are 6502 DISASSEMBLER retrofit ... £35, 6800 disassembler retrofit ... £25 Thermal paper £9.00 box of 10 Clip-over PROBE (only needed if µP is soldered-in) ... £35. Spare cards ... £6.50

£295
+VAT



The Menta Z80 Development System

uses the MOST POWERFUL LANGUAGE OF ALL - direct ASSEMBLER MNEMONICS. MENTA has VISUAL AIDS to program development which the big systems lack: a TV display of PROGRAM, REGISTERS and STACK; single-step operation (watch the cursor move from instruction to instruction, see the register-contents change, observe stack operations, etc.) BUGS can be fixed immediately without reassembling. Full speed operation is supported too - with or without BREAKPOINTS. Designed originally for the Schools' Council to teach microprocessing, MENTA is a complex CENTRAL PROCESSOR in its own right, like any other Z80 system, with practical commercial applications in ROBOTICS. Features include CASSETTE INTERFACE, ASSEMBLER EDITOR, serial DISASSEMBLER (now included as standard), 24 bits of I/O - also TV FLYLEAD, POWER SUPPLY and COMPREHENSIVE MANUAL with SOURCE-CODE LISTING.

£99
+VAT

Goodies from Dataman

Olivetti Typewriter Interfaces

for ET121 and ET221 machines which permit the typewriter to be used as a DAISY WHEEL PRINTER for computers implementing the RS232, IEEE 488 (PET) or CENTRONICS PARALLEL bus: almost all computers in fact. Great for word processing and letter-writing! Same price, fitting free if requested (you pay carriage on typewriter if we fit).

£195.00

Thandar Logic Analyser Enhancements

The THANDAR TA2080 LOGIC-ANALYSER was NOT designed by DATAMAN - but we like this instrument and use it for product development. When writing software we use SOFTY for ROM-EMULATION, following the program-flow on the TA2080 screen. We modified our TA2080 to make it more useful; adding an RS232 OUTPUT TO PRINTER - also Z80 end 6502 DISASSEMBLERS. Now we can follow program operation in MNEMONICS on-screen and print TIMING or STATE DIAGRAMS and DISASSEMBLED CODE. Coat of this RETROFIT kit (12K of program RDM, socket for RS232, interface board, instruction sheet) is, if fitted by us and purchased with a TA2080

£195.00

if purchased as a kit without TA2080

£295.00

Softy 1 with PSU

Yes, we still have a few old faithful 3 rail EPROM PROGRAMMERS around, as seen in Kensington Science Museum, if you are still using 2708's get yourself this fine old classic at a bargain price (telephons for stock postn.)

£95.00

Ultra-Violet Eprom Erasers from

£33.00



Softy Eprom Programmer/Emulator

SOFTY has functions equal, at least, to equipment which sells for over £500. SOFTY EMULATES AND PROGRAMS 2716, 2516, 2732, 2532 EPROMS. (The type is selected by a personality switch. SOFTY will copy any of these EPROMS to any other). SOFTY has a HEX KEYPAD, a fast CASSETTE INTERFACE, a MEMORY MAP TV DISPLAY with powerful editing - such as INSERT, DELETE, SHIFT-BLOCK and many other facilities - too many to list here. RS232 SERIAL and CENTRONICS PARALLEL routines for INPUT and OUTPUT are standard. The price includes TV FLYLEAD, POWER SUPPLY and RDM EMULATOR CABLE WITH 24 PIN DIL PLUG. SOFTY is used as a DEVELOPMENT SYSTEM for new products or just as a STAND-ALONE EPROM PROGRAMMER.

£169
+VAT

All our own work!
Dataman

LOMBARD HOUSE,
CORNWALL ROAD,
DORCHESTER, DORSET DT1 1RX.
Telephone: Dorchester (0305) 68066
Telex 418442 DATAMAN

Dataman
Designs

Prepaid orders normally shipped by return.
Prices include first-class recorded post in UK
Securicor, Red Star, etc. at extra cost.
VAT should be added at current rates

SPEECH SYNTHESISER FOR ZX81 and VIC20

THE MAPLIN TALK-BACK

Now your computer can talk!

- ★ Allophone (extended phoneme) system gives unlimited vocabulary.
- ★ Can be used with unexpanded VIC20 or ZX81 — does not require large areas of memory.
- ★ In VIC20 version, speech output is direct to TV speaker with no additional amplification needed.
- ★ Allows speech to be easily included in programs.

Complete kit only £24.95.

Order As LK00A (VIC20 Talk-Back).
LK01B (ZX81 Talk-Back).

Full construction details in Maplin Projects Book 6.
Price 70p. Order As XA06G (Maplin Mag Vol. 2 No. 6).

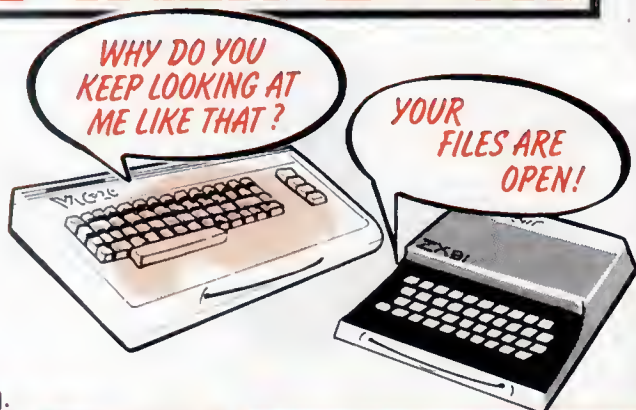

KEYBOARD WITH ELECTRONICS FOR ZX81



- ★ Full size, full travel keyboard that's simple to add to your ZX81 (no soldering in ZX81)
 - ★ Complete with electronics to make "Shift Lock", "Function" and "Graphics 2" single key selections
 - ★ Powered (with adaptor supplied) from ZX81's own standard power supply
- Full details in Project Book 3 (XA03D) Price 60p
Complete kit (excl case) £19.95 Order As LW22P
Case £4.95 Order As XG17T
Ready built-in case £29.95. Order As XG22Y

MATINEE ORGAN

Easy-to-build, superb specification. Comparable with organs selling for up to £1000. Full construction details in our book (XH55K). Price £2 50. Complete kits available. Electronics (XY91Y) £299.95*. Cabinet (XY93B) £99.50* Demo cassette (XX43W) £1.99



* Carriage extra

25W STEREO MOSFET AMPLIFIER



- ★ Over 26W/channel into 8Ω at 1kHz both channels driven
 - ★ Frequency response 20Hz to 40kHz ± 1dB.
 - ★ Low distortion, low noise and high reliability power MOSFET output stage.
 - ★ Extremely easy to build. Almost everything fits on main pcb, cutting interwiring to just 7 wires (plus toroidal transformer and mains lead terminations).
 - ★ Complete kit contains everything you need including pre-drilled and printed chassis and wooden cabinet
- Full details in Projects Book 3 Price 60p (XA030).
Complete kit only £49.95 incl. VAT and carriage (LW71N)

BUY IT WITH MAPCARD

Send now for an application form — then buy it with MAPCARD. MAPCARD gives you real spending power — up to 24 times your monthly payments, instantly



All prices include VAT & carriage. Please add 50p handling charge to orders under £5 total value

MAPLIN'S FANTASTIC PROJECTS

Full details in our project books. Issues 1 to 5: 60p each. Issue 6: 70p

- In Book 1 (XA01B) 120W rms MOSFET Combo-Amplifier • Universal Timer with 18 program times and 4 outputs • Temperature Gauge • Six Vero Projects
- In Book 2 (XA02C) Home Security System • Train Controller for 14 trains on one circuit • Stopwatch with multiple modes • Miles-per-Gallon Meter
- In Book 3 (XA03D) ZX81 Keyboard with electronics • Stereo 25W MOSFET Amplifier • Doppler Radar Intruder Detector • Remote Control for Train Controller
- In Book 4 (XA04E) Telephone Exchange for 16 extensions • Frequency Counter 10Hz to 600MHz • Ultrasonic Intruder Detector • I/O Port for ZX81 • Car Burglar Alarm • Remote Control for 25W Stereo Amp.
- In Book 5 (XA05F) Modem to European standard • 100W 240V AC Inverter • Sounds Generator for ZX81 • Central Heating Controller • Panic Button for Home Security System • Model Train Projects • Timer for External Sounder.
- In Book 6 (XA06G) Speech Synthesiser for ZX81 & VIC20 • Module to Bridge two of our MOSFET Amps to make a 350W Amp • ZX81 Sound on your TV • ZX81 Interface for Modem • Scratch Filter • Doorbell for Deaf • Simple FM Tuner* • Damp Meter*

*Projects for Book 6 were in an advanced state at the time of writing, but contents may change prior to publication (due 11th February 1983)

MAPLIN'S NEW 1983 CATALOGUE

Over 390 pages packed with data and pictures and all completely revised and including over 1000 new items. On sale in all branches of WHSMITH. Price £1.25



OTHER KITS FOR ZX81

- 3-Channel Sounds Generator (Details in Book 5) Order As LW96E Price £10.95
- ZX81 Sound On Your TV Set (Details in Book 6). Order As LK02C. Price £19.95
- ZX81 I/O Port gives two bi-directional 8-bit ports (Details in Book 4). Order As LW76H Price £9.25
- ZX81 Extensiboard will accept 16K RAM and 3 other plug-in modules.
PCB Order As GB0BJ Price £2.32.
Edge Connectors (4 needed) Order As RK35Q Price £2.39

HOME SECURITY SYSTEM

Six independent channels — 2 or 4 wire operation. External horn. High degree of protection and long term reliability. Full details in Projects Book 2 (XA02C) Price 60p



Post this coupon now!

Please send me a copy of your 1983 catalogue. I enclose £1.50 (inc p&p). If I am not completely satisfied I may return the catalogue to you and have my money refunded. If you live outside the U.K. send £1.90 or 10 International Reply Coupons.

Name _____

Address _____

MAPLIN

MAPLIN ELECTRONIC SUPPLIES LTD.
P.O. Box 3, Rayleigh, Essex SS6 8LR
Telephone: Sales (0702) 552911 General (0702) 554155

Shops at: 159 King St., Hammersmith, London W6. Telephone: 01-748 0926
284 London Rd., Westcliff-on-Sea, Essex. Telephone: (0702) 554000
Lynton Square, Perry Barr, Birmingham. Telephone: (021) 356 7292

Note: Shops closed Mondays