

elektor

69
January 1981
ISSN 0308-308X
HK 60p
USA \$2

up-to-date electronics for lab and leisure

200W power amplifier
guitar frequency doubler
audio mixer
disco light displays

Handwritten:
197.2/80

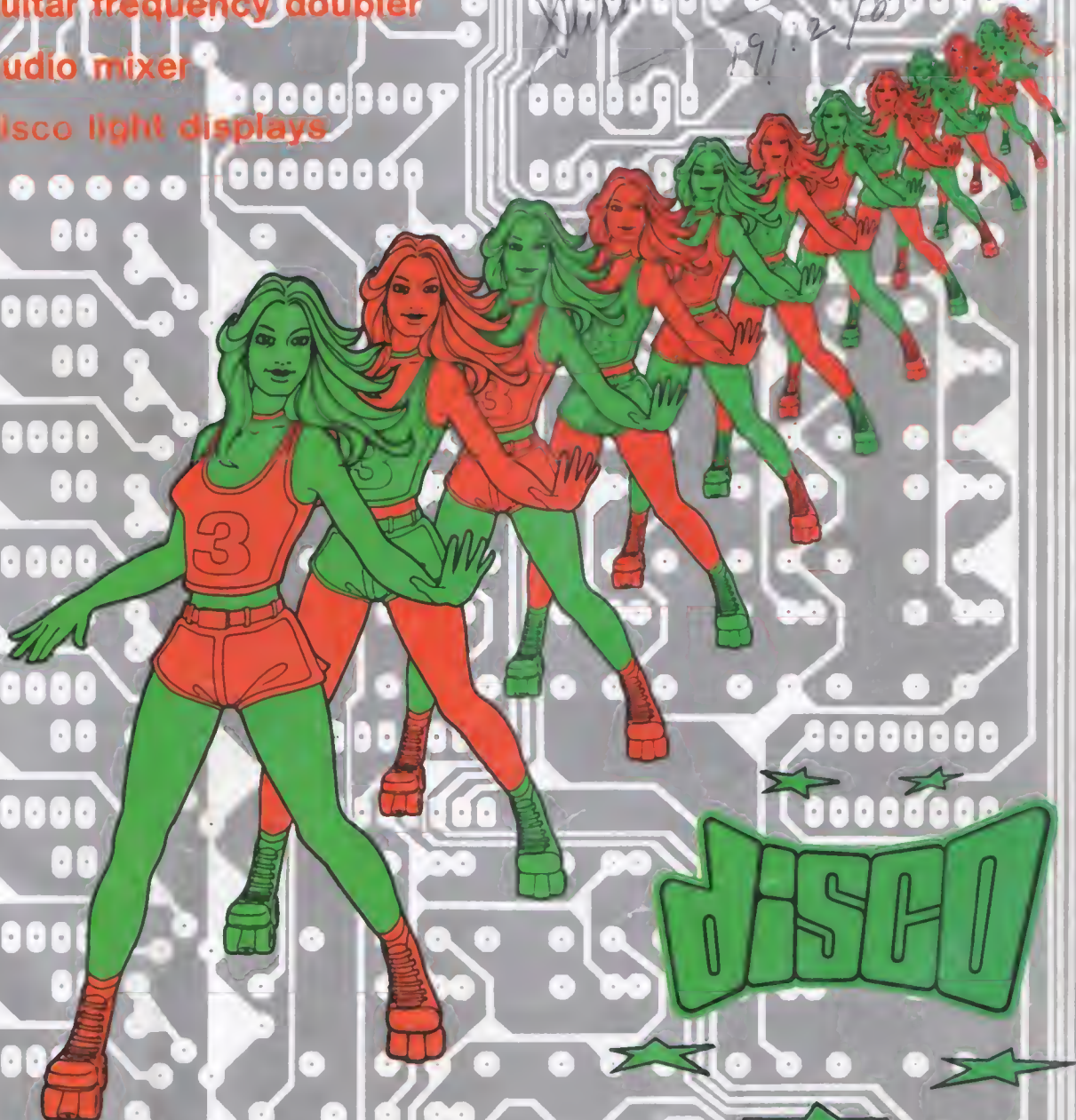

selektor	1-01
disco tips	1-04
A few practical hints and ideas on disco equipment.	
disco ceiling lights	1-07
With the aid of the programmable control circuit described in this article, it is possible to produce a 'dancing light' pattern on the disco ceiling.	
sound pressure meter	1-14
The meter featured in this article will measure actual sound level and give a reading in dBA.	
raw power	1-18
The power amplifier described in this article delivers a good 200 watts into a 4 Ω load.	
mini mixer	1-22
Although this mixer is constructed on one printed circuit board, it can be made as large or small as required.	
level meter (P. de Bra)	1-27
The level meter in this article incorporates a compressor circuit to enable the meter to give a definite indication even at low signal levels.	
circuits and boards	1-29
Ultra violet light and transfers, this article shows how they can add up to a high quality printed circuit board.	
the big VU-meter	1-32
An ordinary VU meter or one that can be read from the other side of a disco hall ... easily.	
swinging poster	1-36
Something different in disco wall decorations. A moving poster that stays in one place!	
BASIC calender (A. Langenberg)	1-40
A year long program for the BASIC computer.	
lower case and graphics for the Elekterminal	1-41
The 'add on' unit in this article enables both upper and lower case characters together with graphic symbols to be displayed on the Elekterminal.	
market	1-44
advertisers index	UK 18

contents

conten
cont
COI

Srinivas Singh

EDITOR:

W. van der Horst

UK EDITORIAL STAFF

T. Day E. Rogans
P. Williams

TECHNICAL EDITORIAL STAFF

J. Barendrecht
G.H.K. Dam
P. Holmes
E. Krempelsauer
G. Nachbar
A. Nachtmann
K.S.M. Walraven



selektor

Non-entertainment auto electronics market to increase four-fold, to £ 200 million, by 1985

Major infrastructure dislocations within the European auto industry and its OEM suppliers will be fostered by the introduction of electronics into automobiles. That is one conclusion reached in a research study that forecasts a four-fold increase in the market for non-entertainment automotive electronics over the next five years to £ 200 million in 1985 - and to more than £ ½ billion by the end of the decade.

The inroads by electronics will cause rapid structural change at all levels of the automotive and supply industries. Market growth by individual product category will be as follows:

Still another likely wrench to the existing infrastructure is the 'world car' concept now under development in the U.S. This presents a threat to European market leadership in small car production. It too, is serving to spur European firms to develop innovative market strategies, especially joint ventures and other forms of collaboration. To create volume markets for example, British Leyland and Honda have entered into a licensing arrangement that commences in 1981. Volvo, Renault, and Peugeot are sharing the same V-6 and 4-cylinder engines. Saab of Sweden and Lancia, a Fiat subsidiary, are planning to produce common automobile components.

All such moves are attempts to survive what will be a stagnant automobile market into the foreseeable future. Indeed, microelectronics promises to offer a new twist, the battle for market share could be fought on the basis of the car interior - the instrument panel, in particular.

Electronics will also become imperative in other ways. As the automobile becomes more sophisticated electronically, wiring looms will become more

area is electronic control of automatic transmission gear shifting. Safety systems using electronic modules will be introduced by mid-1985.

Awaiting development, perhaps more so than any other capability, however, are the sensors and actuators necessary to initiate electronic functional control. Were this area to be tackled in earnest, the market for non-entertainment auto electronics could be double that forecasted.

(598 S)

selektor

Voice-activated typewriter a reality by 1983?

Faster-than-expected progress in the development of speech recognition technology will result in the commercial availability of voice-activated typewriters by 1983 and they will be in 'widespread' use by the end of the decade, according to a report from International Resource Development Inc., a market research firm. A competitive battle is expected to develop between IBM, Xerox and Matsushita for dominance of this market in the mid-1980's, and the IRD report predicts that 'more than one million typists and secretaries will be redeployed as a result of the new machines'.

Secretary must 'clean up' machine's guesses

The first commercial versions of the voice-activated typewriter will correctly recognise about 95% of 'typical' business English as spoken by the average executive, predicts the report. The first IBM units, which IRD expects to be introduced in 1983, will be equipped with a CRT screen which will display the words as they are spoken. Then the dictator, or more likely his secretary, must type in those words which the machine failed to recognise correctly. The IRD researchers believe that the recently-announced IBM Displaywriter product will form the basis for an expanded family of word processing devices, including speech recognition equipment. IBM is already including a 50,000 word vocabulary as a standard feature in the Displaywriter as the basis for 'guessing' the correct spelling of words dictated to the machine. The English language is replete with examples of homonyms and other features which make 100%-accurate machine-recognition almost impossible; however, the Displaywriter already has 'most of the programming' to recognise possible homonyms and highlight them for possible correction.

Selected Products

	(£ million 1979)	
	1979	1985
Electronic regulator power components	4	6
Electronic power semiconductors & electronic modules for multiplexing systems	—	5
Transistorised electronic ignition systems	5.8	21
Electronic spark advance systems	—	25
Electronic fuel injection module market	2	10.6
Digital engine management modules	.4	8
Electronically controlled carburetors	.05	8.2
Electronic automatic transmission control module	—	2.5
Electronic cruise control	.3	1
Lighting directional control	.16	2
Electronic suspension control	.125	1.6
Safety related electronic systems	.2	3.1
Electronic sensors	1.6	10.5
Electronic clock modules	2	6
Electronic dashboard displays	—	28
Trip & drive computer modules	.08	5
Traffic info. systems	1.25	3
Other display & convenience sys.	.2	6.25

Ironically, stiff auto emission, fuel consumption, and safety regulations in the U.S. and Japan, which have spurred work on electronic engine and fuel management systems in these countries, have put European manufacturers at a disadvantage; they have not had the same economic incentive to develop such electronic systems in terms of a large volume domestic market.

The European automotive and electrical systems houses are also under pressure in the information area of electronics, such as route guidance, displays, and trip computers. Here, Siemens, AEG-Telefunken, and other European semiconductor firms are thrusting into their traditional markets as well. VLSI will

complicated and heavy. Multiplexing then becomes necessary, especially in power management systems.

Inroads by electronics will occur elsewhere. Electronic spark advance could become significant after 1983. Over the last 15 years, nearly four million vehicles in Europe have been equipped with electronic fuel injection systems. Integration of spark advance control and fuel delivery is the next obvious and predictable step.

Electronically-controlled carburetors will begin to appear in 1983 at the latest. This function is likely to be combined with transistorised ignition, if not digital spark advance, within a shared module. Still another promising

TIMETABLE FOR THE VOICE-ACTIVATED TYPEWRITER

1980	Rapid advances in speech recognition by Threshold Technology, IBM, Xerox/Kurzweil, Matsushita, Perception Technology and others. First announcement of commercial voice activated typewriter, by Matsushita (for 1983 delivery).
1983	IBM starts delivering voice-activated version of Displaywriter product. Xerox announces high-end VAT. Matsushita delivering Japanese VAT's.
1985	Worldwide VAT shipments reach 25,000. Other U.S. companies, probably including Exxon, active in VAT market.
1986	Some Luddite labor problems encountered in European market; probably few problems in U.S. Japanese VAT market grows rapidly.
1987	VAT shipments exceed 100,000. Larger volumes lead to significant price drops.
1990	Cumulative VAT shipments approach one million. Noticeable impact of VAT's in routine of many offices. Value of VAT shipments exceeds value of regular typewriter shipments.

SOURCE: INTERNATIONAL RESOURCE DEVELOPMENT INC.



Source: INTERNATIONAL RESOURCE DEVELOPMENT INC.

Languages which are more phonetic than English are 'much easier' to use in speech recognition applications; according to the report this will mean that Matsushita's voice-activated typewriter (also expected in 1983) will do a better job on Japanese than the IBM machine will do on English. A 'very high quality' voice-activated typewriter is also expected from Xerox 'not later than 1984', and Exxon is described as being a 'dark — but fast — horse in the VAT

race'. Other potential suppliers of VAT equipment may include Olivetti and Wang, predicts IRD.

No major redundancies of secretaries forecast

The new 'typewriters with ears' will result in some changes in the office environment, the IRD researchers expect, but IRD sees little prospect of widespread redundancies of secretaries. Most likely they will find their jobs enriched and expanded as a result of the

new technology. It is considered that a shortage of qualified secretarial employees will continue into the 1990's, despite increasingly rapid momentum in the office automation market.

Also included in the report are predictions of rapidly-increasing use of speech recognition and voice synthesis in home appliances and consumer products, including the 'imminent' introduction of voice-recognition on TV channel tuners and automobile ignition locks. Texas Instruments' 'Speak & Spell' product is expected to be followed by several new types of toys, educational devices and calculators which include speech output capabilities.

(600 S)

selektor

Prototype disc digital audio completed

N.V. Philips' Gloeilampenfabrieken of the Netherlands and Sony Corporation of Japan announced last June that their mutual cooperation has led to further improvements in the optical digital compact disc system. These further improvements are particularly in the field of modulation and error correction.

The two companies have been actively engaged in further experimental work, which has meanwhile succeeded in a prototype of player and disc in the new format.

Philips and Sony presented and demonstrated the latest improvements in the system — which has been given the name of the 'compact disc digital audio' system — to the public at the 29th all Japan Audio Fair held in the Harumi International Fair site during October.

The 'compact disc digital audio' system jointly developed by the two companies is fulfilling all original requirements for a new audio disc system. Superior sound reproduction is being combined with miniaturisation of the disc, no wear of disc and pick-up and effective protection against dirt and damage. Digital high density recording and optical reading has made possible a continuous playing time of about 60 minutes on one side of a 12 cm disc. A substantially smaller player than any conventional player has emerged using a solid state laser and high precision miniature components. In the meantime, the two companies have submitted the promising 'compact disc digital audio' system to the digital audio disc standardisation conference and all efforts are exerted to

help promote a common world-wide specification acceptance.

The main characteristics of the system are:

1. It is optical, using a solid state laser — due to the contactless pick-up system a long lifetime for disc and player is ensured. The disc is nearly free from influence of dust, scratches and fingermarks on the surface, whereas there is no need for a case.
2. It is compact — the disc measures 12 cm across. The system permits 60 minutes of high-density recording on a single side equalling the maximum total playing time of two sides of the present 30 cm LP. Handling and storage of the disc has become much easier.
3. It is a digital system — digital registration of the sound signal, using pulse code modulation, leaves space for insertion of additional information, such as text and programming data in encoded form for visual display, track selection and preprogramming. It also permits a very efficient modulation system for high packing density recording and an error correction system which combines a very high capability of detecting random errors with a very low probability of undetectable errors. The main specification of the system:

Disc	
Playing time (one side)	60 min. (2 channels)
Track pitch	1,6 µm
Size of disc	120 mm
Thickness of disc	1.2 mm
Signal format	
Quantisation number	16 bit linear quantisation/channel
Sampling frequency	44.1 kHz
Error correction	CIRC (cross interleave reed solomon code)
Modulation	EFM (eight to fourteen modulation)



is performed by feeding the electrical signals from an amplifier to the relatively large diaphragm of the loudspeaker. And it is the diaphragms that are at fault. Why? Loudspeaker cones have to retain a high degree of structural rigidity in order to prevent sound colouration. The mass of the cone automatically compounds the problem as the more

point will be heavily ionised. Thus the temperature around it will rise considerably so that the surrounding air will expand explosively. It is logical therefore that the rise in temperature is proportional to the intensity of the corona discharge, since it is determined by the number of ionised gas molecules. As a result of the amplitude modulation of the high frequency, and high voltage, the changes in temperature have been found to have an average value of 15000°. Naturally, these changes in temperature cause the air pressure to fluctuate.

In this way, the modulation signal is converted into a sound wave. In practice, not enough heat is dissipated around the corona discharge at frequencies of several hundred thousand Hertz. This means the electrical modulations can no longer be converted into heat changes and so the frequency range of the unit becomes limited to around 3000 ... 200,000 Hz!

The corona discharge constitutes a virtually ideal pointed, pulsating source of sound and can boast acoustic qualities which previously seemed impossible to achieve. The sound is deflected in an 'omnidirectional' pattern, which means that the sound pressure is equally powerful in all directions (114 dB). This effect is enhanced by the gauze 'mantle' surrounding the corona discharge. In addition, this ensures that the ozone produced is 'confined'.

*Wagner and Wagner Company Ltd.,
St. Jorisstraat 34, 6511 TD Nijmegen,
The Netherlands.*

(590 S)

selektor
SELEKTOR

Corona Plasma loudspeaker

Hi-fi equipment still has many faults and weaknesses, the greatest being the loudspeakers. Not surprising when you consider that the latest amplifiers, tuners, record players and the like have specifications that speaker manufacturers can only dream about. Time and again new designs turn up on the market in a seemingly desperate bid to iron out all the imperfections associated with the very principle behind the loudspeaker. What is that principle? Well, in order to generate sound, air molecules have to be 'stirred up' so that they can transfer the sound information to the ear of the listener. This function

inertia that has to be overcome, the poorer the response to the input signal. In the near future (towards April 1981), Magnet Electronics Ltd. of Cologne, West Germany, will be introducing a new type of high frequency horn which will go a long way to solving the above problems. The newcomer to the speaker scene will be christened the 'Corona Plasma Loudspeaker' and is based on an idea by the French physicist Dr. Siegfried Klein who (believe it or not) invented the 'lonophone' speaker some thirty years ago.

Of course at that time there were all sorts of drawbacks involved, but fortunately the new Corona Plasma version has eliminated most of them. The system works as follows: A high frequency (27 MHz) oscillator with a power output of 20 W is amplitude modulated by the low frequency information which is to be reproduced. This voltage is then increased via a transformer and fed to a needle electrode causing a corona discharge to take place at the needle point, as a result of which the air molecules around the

selektor
SELEKTOR

We don't have to describe to anybody just what a disco is, but we can offer a few suggestions for improving, updating and personalising existing disco equipment. With the aid of one or more of the projects described in this issue it is possible to add extra power or lighting effects to make your disco "completely different". One of the articles describes a disco ceiling which gives very interesting lighting effects. Of course, as mentioned in the article, the principle could also be applied to a wall. Just think how your parties would swing with a whole wall of your living room pulsating and glowing with coloured light patterns (like something out of *Close Encounters!*). Electronics helps to accentuate the excitement of the overall scene and originality can make all the difference to the popularity of the particular disco.

Disco electronics

The lights . . .

Most discotheques nowadays are specially equipped for the latest sounds, which involves a considerable amount of reconstruction, decoration and installation work. After all, they are no longer merely places to dance, but colourful palaces vibrating to an exhibition of sound, light and colour. The effects are enhanced by means of liquid wheel projectors, revolving mirrors, running lights, light pipes, illuminated floors, ceilings etc, the entire combination being programmed to move with the music.

Articles contained in this issue provide versatility and describe how special lighting effects can be achieved with the aid of several "easy to build" circuits such as "level meter", the "swinging poster" and the "disco ceiling lights". They can also be used by disco fans to put on their own show or throw an extra special party at home. Discotheque owners are now able to add that extra something special to their disco system.

Of course, building liquid wheel projectors and laser guns is somewhat beyond the capabilities of the average amateur, but running lights and various other types of flashing lamp systems, equally effective, are circuits which have been published at regular intervals in *Elektor* and therefore will be easy enough to tackle. If in doubt, make sure your house is fully insured before you start!!

What about the cost of all this disco equipment? Well, before you read the following you had better fix yourself a stiff drink, because expenses have been known to run as high as £70,000!! That is if the job is done professionally. Obviously, the cost of the circuits published in this issue (or any issue of

disco tips

Saturday Night Fever did more than turn a few heads. It made an already vast disco-going population respectable throughout Europe. The film was the first of its type and stole the hearts and feet of millions. With the upsurge in the number of professional discos all over the country, various manufactures resorted to the production of special disco equipment. Now a disco is as normal to every age group as . . . Terry Wogan?

1



Figure 1. A group of the smaller, but very powerful loudspeaker units intended for disco use.

Elektor for that matter) will certainly not come anywhere in the region of that figure.

... and the sound

The lights by themselves would be fine for deaf people (as frequent disco-goers often become), but the sound is also a very important factor. To give an idea, the sound levels usually produced, can reach figures in the 105...115 dB range. Readers who may be a bit sceptical about this can measure it with the aid of the "sound pressure meter" described elsewhere in this issue. A level of around 105...115 dB is equivalent to that produced by a pneumatic drill at a yard's distance and only the noise produced by a jet during take-off can better it.

People may think that their ears can get acclimatised to it - with practice. However, they should bear in mind that levels of this order are enough to cause permanent damage to the inner ear - especially when endured for hours at a time.

Not only the level, but also the quality of the sound is important. Early discos seemed to get by with low quality reproduction, but the modern trend is turning towards hi-fi performance (with high power). Quality amplifiers in the 200...300 W range are becoming more and more common. Very often, several such "monsters" are combined in a single installation. The "200 W power amplifier" has been designed partly with discos in mind and will rock the floor nicely.

The turntables constitute another vital ingredient to the potpourri of sound. Obviously, they will have to be of solid construction and quick starters. Efficient mechanical decoupling from the immediate surroundings is an absolute must. As far as the cartridge is concerned, a compromise is usually made between strength and performance, but again, robustness is very important. So an average quality cartridge with more pressure than is considered "quite proper" in hi-fi circles will be needed to cope with all the rough-and-tumble going on around it. Several types are available that have been designed specifically for disco purposes.

Other equipment required will include microphones and a tape deck of sorts. The modern disco desk almost inevitably includes a mixer to cope with the wide range of equipment - like the "mini mixer" presented in this issue. Also, the "big VU meter" will add that extra little personal touch to your disco set-up.

Loudspeakers

Well, if power levels are to exceed the 200...300 watt mark, the loudspeakers will have to be something special. Among the big names in this field are Fane, Goodmans, Celestion and JBL

2



Figure 2. The "insides" of one of the range of loudspeakers cabinets from JBL. It contains no less than five different speaker units.

to name but a few. The really "heavy stuff" for discotheques is provided by companies like Altec Lansing, Electrovoice, JBL and Cerwin-Vega - naturally, these tend to be rather on the expensive side. The photographs show various examples of the type of speakers and cabinets normally used.

As can be seen from figures 1...3 they include bass speakers of various proportions. A glimpse of what is involved behind the scenes (in this case the JBL) is also given in figure 2. It consists of a very large bass loudspeaker with a "hefty" magnet, two powerful speakers for the lower-mid range, one for the mid range and a horn with a diffraction grating for the high range. Each one is a driver with exceptionally high power output and capable of producing enough volume to take the roof off.

At Electrovoice they don't believe in half measures either, as the slim version in figure 3 proves. Again, it contains horns for the high and mid ranges and

a double folded horn for the low frequencies. Its name "Eliminator" certainly fits the bill here, as it will wipe the floor with anyone who dares to venture within a yard of the cabinet.

Sony, Pioneer and various other companies are currently developing high-power loudspeakers for mobile discos (ideal for passion wagons!). While not being particularly suitable for a normal living room they can create a very reasonable sound for discos in flats etc, but would be considerably improved when combined with a bass cabinet.

Is it possible to construct speaker cabinets like the ones illustrated in figures 1...4 at home? In principle, of course, anything is possible, but it might be wise to select a size more in keeping with that of your house (not all of us can afford mansions!). Construction of your own loudspeaker cabinets can be something of a tricky business; however, if you stick to the rules laid out in the countless

books on the subject, if you pay heed to the manufacturer's recommendations and if you are a skilled carpenter, the results of your efforts can be surprisingly good. Some firms have even made it their speciality to supply evrything the amateur constructor needs in the way of materials. Companies such as Fane, Richard Allen and Celestion also include "heavy" items in their repertoire. These are primarily intended for public address installations, but are ideal for high power disco units.

A remark or two on construction. The maxim for high power speaker cabinets is "the more solid the better". Do not attempt to cut down on the thickness of the wood: follow the manufacturer's advice, he really does know what he is talking about! If anything, use double the thickness and keep the panels firmly in place by inserting cross members inside the cabinet. Stinginess in this

4



Figure 4. Loudspeaker units intended primarily for the car are also suitable for use in mobile discos, flats etc.

3



Figure 3. The Electrovoice "Eliminator", one of the truly "heavy" loudspeaker cabinets — in every sense of the word!

respect will inevitably lead to panel resonance which is not only impossible to eliminate, but also causes considerable distortion.

When constructing your own multi-way loudspeaker system, it is advisable to use the same brand of speakers throughout, together with their recommended crossover networks and combine them as suggested by the manufacturer. Manufacturers spend a great deal of time and effort in the development of their ideas and their reputation is based on their success. If, however, you are not deterred and wish to experiment with various types, it is important to ensure that the performance of each speaker unit is compatible with the rest.

Normally speaking, the technical specification of a loudspeaker is indicated in terms of dBs, representing the sound pressure measured at a distance of one yard from the speaker when subjected to a signal of $2,83 V_{pp}$ and in the case of an 8Ω speaker, this corresponds to one watt. Manufacturers indicate the actual power handling capability of the loudspeakers in watts and this could be more important to the average disc jockey.

Final word of advice

Whatever the cost of the equipment, that is not the end of the story. It's *how* the equipment is put to use that counts. This is in fact considered by many to be an art in itself.

Lights are very often "strung up" in such an inartistic and haphazard fashion that they often defeat their own objective. The sound system can also prove to be somewhat of a nightmare when speakers are placed ineffectively. As every performer knows (or should do) the success of the show depends upon the presentation. A little care and attention when setting up the equipment could well lead to another booking. ❖

the 'high light' of a disco

disco ceiling lights

The 'show' element plays a dominating role in today's modern discotheque. A combination of sound to light systems, running lights, liquid wheel projectors, strobes, laser beams and illuminated ceilings succeed in producing a whirling show of sound, light and colour. The modern disco ceiling is made of a transparent material and is divided into squares. Each square contains some form of lighting unit. With the aid of a programmable (or pre-programmed) control circuit it is possible to produce all sorts of weird and wonderful light patterns to 'dance' across the ceiling. This article takes a look at a possibility of what the electronics involved could look like.

Before getting too involved in the electronics of the system we need to have a look at the actual ceiling itself. The control circuit, described later on, is designed for a ceiling that has been split up into 25 sections in a 5 x 5 matrix. Each section of the ceiling will contain a light bulb with a power rating of anything up to 100 W. Obviously, some form of (coloured) light diffuser is necessary to cut down the amount of 'glare'. Although this article primarily describes a ceiling unit, there is no reason why the principle could not be applied to a wall or even the floor. The layout of the lamps is given in figure 1. The number in each square correspond to the connection details on the circuit diagram and the printed circuit board. Whether or not a lamp is

sequence the program pauses even longer to indicate the transition to the next sequence. Even if one pattern closely resembles its predecessor, a fairly long pause is necessary between each one in order that the change can be clearly observed. For these reasons the circuit contains two monostable multi-vibrators: one (MMV1) for the short pauses and the other (MMV2) for the slightly longer pauses. Outputs Q₆ and Q₇ of the EPROM are used to trigger the respective monostables. The outputs of the two monostables are NORed together so that either of them will inhibit the clock generator and thus temporarily halt the program. Table 1 also provides a figure for the interval length between each pattern: a '1' indicates a short (MMV1) pause and

actually turned on is determined by a 'program' written beforehand. This program is stored in digital form in a memory IC. If the memory chip is programmed as detailed later, up to twenty two different combinations of patterns can be displayed on the 5 x 5 matrix — enough for even the most 'mind-boggling' of shows. A set of possible combinations is given in table 1. Each combination consists of a series of different patterns which follow each other in the order shown. The EPROM address area containing the display data (see table 3) is also shown. It will be apparent that names and messages can be programmed to appear on the ceiling, one letter at a time or even 'running'.

Block diagram

The control circuit for the ceiling lighting is shown in the form of a block diagram in figure 2. The program is stored in a 1 k-byte (1024 x 8 bit) EPROM (Erasable Programmable Read Only Memory). The EPROM is programmed in such a way that the information at outputs Q₀ . . . Q₅ (= 6 bits) control the actual turning on or off of the individual lamps. The address lines of the EPROM are controlled by a 10-bit binary counter. Following each pulse produced by the clock generator (there is a slight delay built in) the binary counter (and thus the address) is incremented by one so that each of the memory locations are 'read' in turn. The pattern is built up (or broken down) one lamp at a time, but the process is so fast that the pattern appears to be present all the time.

For this reason, the program is halted for a short period of time upon completion of each separate pattern in order that the onlooker has time to appreciate each one. At the end of each pattern

a '2' indicates a long (MMV2) pause.

The frequency of the clock generator is variable so that the actual speed at which the patterns are built up can be chosen at will. At very low clock frequencies it is possible to see the patterns being built up one lamp at a time, which, understandably, produces a completely different effect to that of seeing the entire pattern displayed all at once. It is also possible to step through the program manually (one lamp at a time) for testing purposes.

The lamps are not turned on and off directly by the EPROM, but rather via a decoder/latch and a mains interface. Information presented via the Q₀ . . . Q₄ outputs of the EPROM is decoded to determine which of the lamps is to be 'addressed' and the Q₅ output determines whether or not that lamp is to be turned on. Each time the EPROM outputs a lamp address the data (lamp on or off) will be stored in a 25-bit latch. Once a pattern has been completed, either Q₆ or Q₇ of the EPROM will be 'high', depending on whether the current pattern is one of a series or the last in the series respectively. When one of these outputs are high, the corresponding monostable (MMV1 or MMV2) will be triggered and the clock generator will be inhibited. The display pattern will then remain 'stationary' for a short length of time. This time period is adjustable and when it is over the build up of the next pattern to be displayed will commence.

If a pattern is entirely different from the previous one it is best to start from 'scratch' (this can lead to a saving of memory space). The 25-bit latch can be 'cleared' by entering data into the highest possible latch location. This in fact corresponds to a data byte of 3F (hexadecimal) being output from the EPROM. When this information is presented to the decoder the master reset

1

La 1	La 2	La 3	La 4	La 5
La 6	La 7	La 8	La 9	La 10
La 11	La 12	La 13	La 14	La 15
La 16	La 17	La 18	La 19	La 20
La 21	La 22	La 23	La 24	La 25

81012 1

Figure 1. The disco ceiling is made up of 25 (square) sections, each individually lit by a 100 W lamp.

Table 1. These patterns are produced by the program given in table 3.

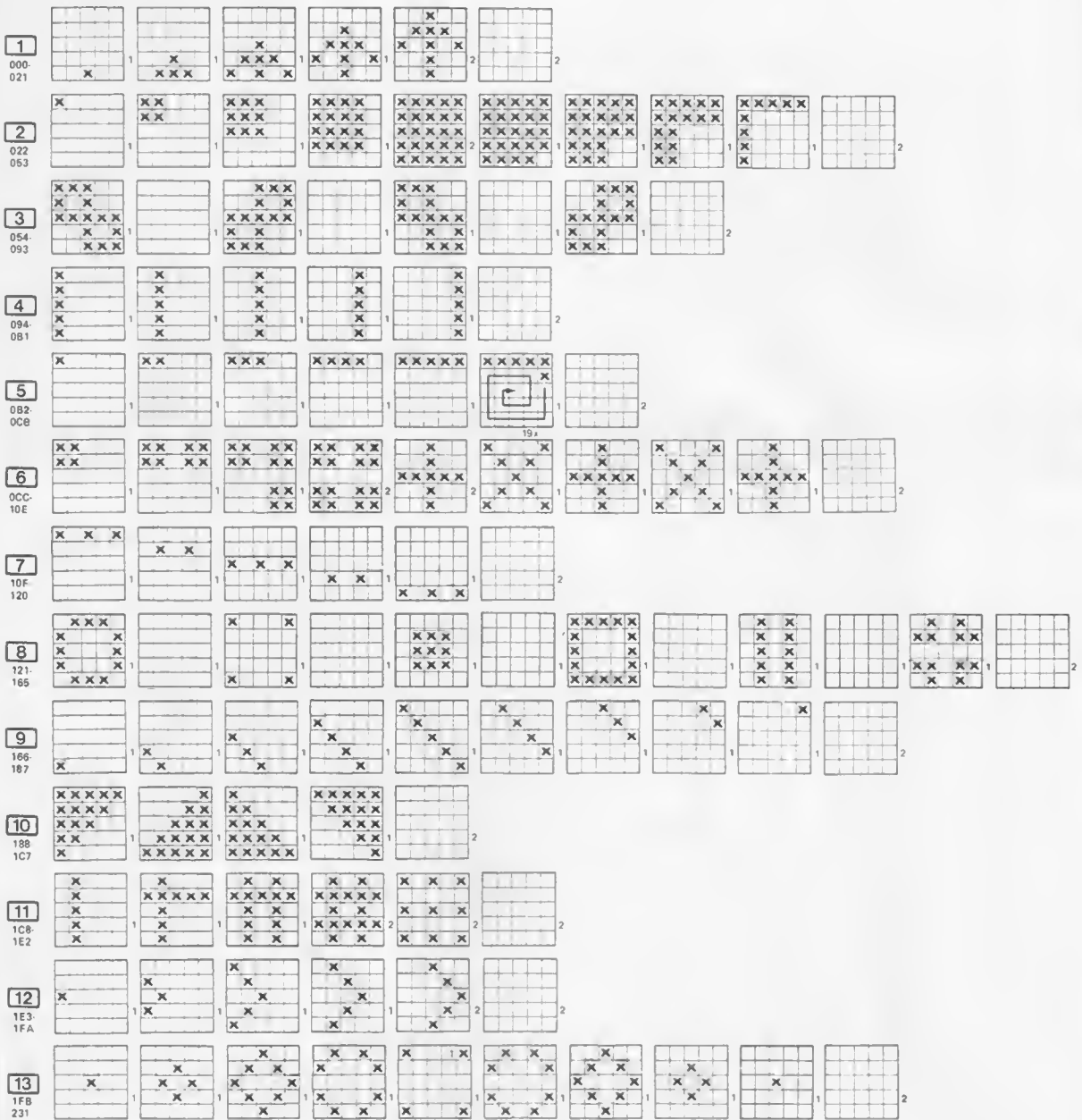

line (MR) will go high, all the latch data will be erased and all the lamps will be turned off. Table 2 shows part of the program expressing the above procedure in 'software language'.

As far as the mains interface is concerned, this consists of 25 triac control circuits to turn the individual lamps on and off. For the sake of economy, no optocouplers have been incorporated. In other words, the circuit is connected directly to the mains, *so watch where you're putting your fingers!!* (More about this when we come to the constructional details).

To avoid mains interference the triacs are only triggered when the mains voltage 'crosses zero'. This is taken care of

(as you may have guessed) by the zero crossing detector.

The only section of the block diagram hitherto unmentioned is the 'power supply'. This produces three separate supply voltages: +5 V, -5 V and +12 V. The latter two are required by the EPROM while the +5 V supply is required by the complete circuit.

Circuit diagram

The entire circuit diagram of the lighting control unit is given in figure 3. The EPROM (IC1) is shown on the right hand side of the diagram. One advantage of using this type of memory device is that the information is not lost when the power supply is turned off (as

opposed to RAM). Also, the program can be modified at any time if required, unlike ROM or PROM. The actual program contained in the EPROM is another matter, which will be dealt with later on.

Moving back to the circuit diagram, IC2 is the 10-bit binary counter which addresses the EPROM. In turn, the binary counter is clocked by the oscillator formed by gate N2. After each clock pulse the binary (address) counter is incremented by one so that the entire contents of the EPROM are read out sequentially. The speed at which each program 'instruction' is carried out can be adjusted between about 2 Hz and 400 Hz by means of potentiometer P1.

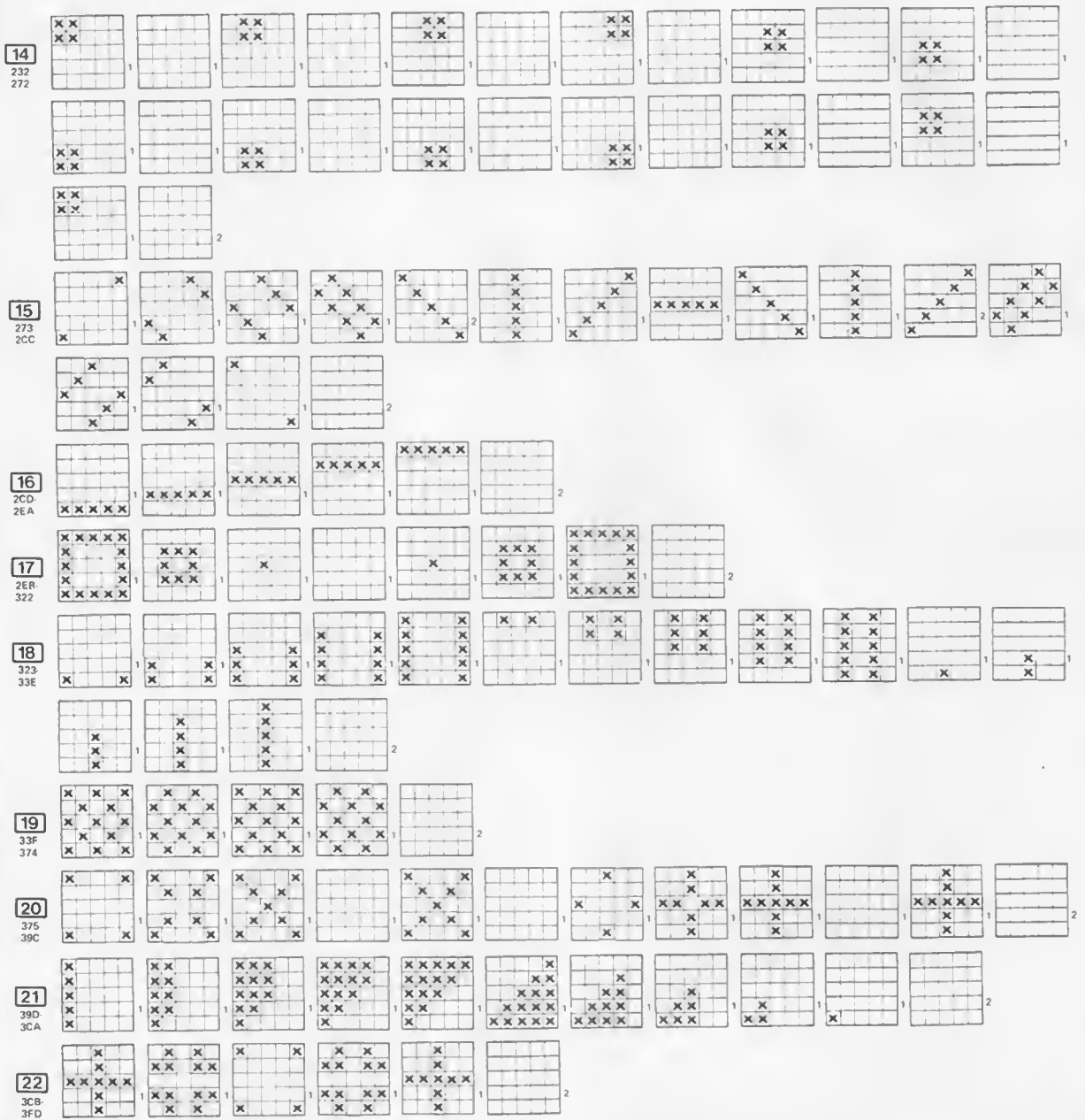

The program can be run one instruction at a time by operating pushbutton S1, provided of course that switch S2 is in the 'step' position.

The data appearing at the outputs $Q_0 \dots Q_5$ of the EPROM are decoded by IC3a and IC6 ... IC9. The latter each contain eight addressable latches. By addressing the latches via inputs $A_0 \dots A_2$ the value of Q_5 ('0' or '1') presented to the data input (D) at that given moment will be stored in the addressed latch, provided the enable input (\bar{E}) is logic zero. This means that data can only be stored in one latch per address. The 'contents' of the latches appear at outputs $Q_0 \dots Q_7$ (of IC6 ... IC9).

Table 2

HEX	EPROM DATA								
	interval		data on/off	addresses					
	Q_7	Q_6		lamp 1 ... 25					
	Q_7	Q_6	Q_5	Q_4	Q_3	Q_2	Q_1	Q_0	
26	0	0	1	0	0	1	1	0	lamp 3 on
71	0	1	1	1	0	0	0	1	lamp 17 on, interval 1
86	1	0	0	0	0	1	1	0	lamp 3 off, interval 2
3F	0	0	1	1	1	1	1	1	highest address: master reset

Table 3. Hex dump.

```

000: 77 17 37 32 38 76 3F 37 32 2D 33 31 39 75 3F 37
010: 32 2D 28 2E 2C 34 70 3F 37 32 2D 28 23 29 27 2F
020: AB BF 61 22 27 66 23 28 2D 2C 6B 24 29 2E 33 32
030: 31 70 25 2A 2F 34 39 38 37 36 B5 59 18 13 54 17
040: 12 0D 0E 4F 16 11 0C 07 08 09 4A 15 10 0B 06 01
050: 02 03 04 85 21 22 23 28 2D 32 37 38 39 34 2F 2E
060: 2C 2B 66 7F 25 2A 2F 2E 2D 2C 2B 30 35 36 37 32
070: 28 23 64 7F 21 22 23 28 2D 32 37 38 39 34 2F 2E
080: 2C 2B 66 7F 25 2A 2F 2E 2D 2C 2B 30 35 36 37 32
090: 28 23 64 BF 21 26 2B 30 75 3F 22 27 2C 31 76 3F
0A0: 23 28 2D 32 77 3F 24 29 2E 33 78 3F 25 2A 2F 34
0B0: 79 BF 61 62 63 64 65 6A 6F 74 79 78 77 76 75 70
0C0: 6B 66 67 68 69 6E 73 72 71 6C 6D BF 21 22 27 66
0D0: 24 25 2A 69 33 34 39 78 30 31 36 B5 3F 23 28 2D
0E0: 32 27 2B 2C 2E AF 3F 25 29 2D 31 35 21 27 33 79
0F0: 3F 2F 2E 2D 2C 2B 23 28 32 77 3F 39 33 2D 27 21
100: 25 29 31 75 3F 37 32 2D 28 23 2F 2E 2C 6B BF 21
110: 23 65 3F 27 69 3F 2B 2D 6F 3F 31 73 3F 35 37 79
120: BF 22 23 24 2A 2F 34 38 37 36 30 2B 66 7F 21 25
130: 39 75 7F 27 28 29 2C 2D 2E 31 32 73 7F 21 22 23
140: 24 25 2A 2F 34 39 38 37 36 35 30 2B 66 7F 22 27
150: 2C 31 36 24 29 2E 33 78 7F 22 27 26 24 29 2A 38
160: 33 34 36 31 70 BF 75 3F 30 76 3F 2B 31 77 3F 26
170: 2C 32 78 3F 21 27 2D 33 79 3F 22 28 2E 74 3F 23
180: 29 6F 3F 24 6A 3F 65 BF 21 22 23 24 25 26 27 28
190: 29 2B 2C 2D 30 31 75 3F 39 34 2F 2A 25 38 33 2E
1A0: 29 37 32 2D 36 31 75 3F 35 36 37 36 39 30 31 32
1B0: 33 2B 2C 2D 26 27 61 3F 25 2A 2F 34 39 24 29 2E
1C0: 33 23 28 2D 22 27 61 BF 22 27 2C 31 76 26 28 29
1D0: 6A 24 2E 33 78 30 32 B4 3F 21 23 25 2B 2D 2F 35
1E0: 37 B9 BF 6B 0B 2C 30 66 3F 2D 31 27 35 61 3F 2E
1F0: 32 28 36 62 3F 2F 33 29 37 A3 BF 6D 3F 28 2E 32
200: 6C 3F 23 29 2F 33 37 31 2B 67 3F 24 2A 34 38 36
210: 30 26 62 3F 25 39 35 61 3F 24 2A 34 38 36 30 26
220: 62 3F 23 29 2F 33 37 31 2B 67 3F 28 2E 32 6C 3F
230: 6D BF 21 22 27 66 7F 22 23 28 67 7F 23 24 29 68
240: 7F 24 25 2A 69 7F 28 29 2E 6D 7F 2C 2D 32 71 7F
250: 30 31 36 75 7F 31 32 37 76 7F 32 33 38 77 7F 33
260: 34 39 78 7F 2D 2E 33 72 7F 27 28 2D 6C 7F 21 22
270: 27 66 BF 25 75 3F 24 2A 30 76 3F 23 29 2F 2B 31
280: 77 3F 22 28 2E 34 26 2C 32 78 3F 21 27 2D 33 B9
290: 3F 23 28 2D 32 77 3F 25 29 2D 31 75 3F 2F 2E 2D
2A0: 2C 6B 3F 39 33 2D 27 61 3F 37 32 2D 28 63 3F 35
2B0: 31 2D 29 A5 3F 36 32 2E 2A 30 2C 28 64 3F 37 33
2C0: 2F 2B 27 63 3F 38 34 26 62 3F 39 61 BF 35 36 37
2D0: 38 79 3F 30 31 32 33 74 3F 2B 2C 2D 2E 6F 3F 26
2E0: 27 28 29 6A 3F 21 22 23 24 65 BF 21 22 23 24 25
2F0: 2A 2F 34 39 38 37 36 35 30 2B 66 3F 27 28 29 2E
300: 33 32 31 6C 3F 6D 7F 6D 3F 27 28 29 2E 33 32 31
310: 6C 3F 21 22 23 24 25 2A 2F 34 39 38 37 36 35 30
320: 2B 66 BF 35 79 30 74 2B 6F 26 6A 21 65 3F 22 64
330: 27 69 2C 6E 31 73 36 78 3F 77 72 6D 68 63 BF 21
340: 23 25 27 29 2B 2D 2F 31 33 35 37 79 3F 22 24 26
350: 28 2A 2C 2E 30 32 34 36 78 3F 21 23 25 27 29 2B
360: 2D 2F 31 33 35 37 79 3F 22 24 26 28 2A 2C 2E 30
370: 32 34 36 78 BF 21 25 39 75 27 29 33 71 6D 7F 21
380: 27 2D 33 39 25 29 31 75 7F 2B 2F 23 77 2C 2E 28
390: 72 6D 7F 2B 2C 2D 2E 2F 23 28 32 77 BF 21 26 2B
3A0: 30 75 22 27 2C 71 23 28 6D 24 69 65 3F 35 36 37
3B0: 38 39 31 32 33 34 2D 2E 2F 29 2A 65 19 14 0F 0A
3C0: 45 18 13 0E 49 17 12 4D 16 51 BF 23 28 2D 32 37
3D0: 2B 2C 2E 6F 3F 22 27 26 24 29 2A 36 31 30 38 33
3E0: 74 3F 21 25 39 75 3F 26 27 22 2A 29 24 30 31 36
3F0: 34 33 78 3F 37 32 2D 28 23 2F 2E 2C 6B BF 00 00

```

Outputs $Q_0 \dots Q_2$ of the EPROM control inputs $A_0 \dots A_2$ of each of the latch ICs. Outputs Q_3 and Q_4 are fed to a 2 line to 4 line decoder (IC3a) to determine which of the four latch ICs are to be enabled. If, for instance, IC8 is to be enabled, Q_3 of the EPROM will be low while Q_4 will be high. This means that the \bar{Q}_2 output of IC3a will be low thereby the enable input (\bar{E}) of IC8 will also be low. The data at the D input of IC8 (Q_5 of the EPROM) at that moment will then be stored in whichever of the latches is being addressed by outputs $Q_0 \dots Q_4$ of the EPROM. The binary values of these outputs corresponds to the decimal figures that are indicated at the outputs of IC6 ... IC9.

The outputs of the latches are connected to the (25) triac control circuits via resistors R9 ... R33. The zero crossing detector is constructed around gates N5 ... N8 and ensures that the triac drivers (T1 ... T25) only receive supply voltage for about 250 μ s each time the mains voltage crosses zero. Only then can a triac be triggered and once it is conducting it will continue to do so for one half cycle. By turning on the triacs during the zero crossings, current surges are reduced to a minimum and therefore the possibility of mains interference is also reduced.

As mentioned previously, the execution speed of the program in the run mode is determined by the frequency of the clock generator N2. To obtain the necessary pauses between each pattern build up, or sequence of patterns, the clock generator will have to be temporarily inhibited. This is accomplished via outputs Q_6 and Q_7 of the EPROM. By programming the binary values '01' and '10' in these memory locations, monostables MMV1 and MMV2 (of IC4) can be triggered via the Q_1 and Q_2 outputs of the second 2 line to 4 line decoder (IC3b) respectively.

The outputs of the two monostables are fed to the NOR gate N1, which disables the clock generator when either of the MMV outputs go high. The EPROM address counter use then no longer incremented and 'picture' will be stable for a short while. The pulse duration of MMV1 can be adjusted between about 0.1 and 1.2 seconds by means of potentiometer P3 while that of MMV2 can be adjusted between about 0.4 and 6.0 seconds by means of potentiometer P2.

Observant readers may well be wondering about the purpose of the second 2 line to 4 line decoder (IC3b). Surely its job can be performed by the Q_6 and Q_7 outputs of the EPROM directly? Wrong! Just before the EPROM provides new information, the outputs are in an indefinite state for a short period of time. Obviously, this makes matters very awkward if data were to be decoded at that particular instant. The pulse delay network R2/C2 ensures that the binary counter (IC2) does not

increment the EPROM address until IC3a and IC3b have been disabled ($\bar{E} = 1$). Only when the EPROM outputs are stable will IC3a and IC3b be enabled ($\bar{E} = 0$). The procedure is as follows: When the clock pulse derived from N2 goes low, the output of N4 will go high, thereby disabling IC3a and IC3b. A short time later (R2/C2) the binary counter will be incremented and the EPROM address updated. The clock frequency is such that the output of N2 will not go high until the information on the EPROM outputs is stable. When the output of N2 does go high, however, it will have no effect on the binary counter, but IC3a and IC3b will now be enabled via N4. The information presented to the inputs of these decoders will then (and only then) be passed on to their outputs.

The power supply for the lighting control unit can be described very briefly. It consists quite simply of a transformer, a bridge rectifier, a few smoothing capacitors and three integrated voltage regulators (IC10...IC12). These voltage regulators provide the +12 V, +5 V and the -5 V supplies respectively. It is important to use this particular type of integrated voltage regulator in this circuit as they are protected against thermal overload and are virtually short circuit proof (note that no fuses have

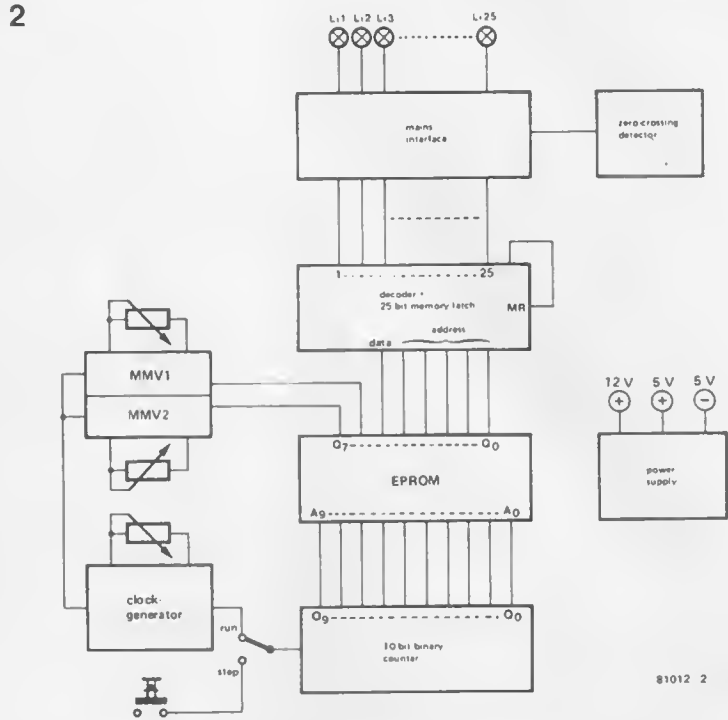

Figure 2. The block diagram of the control unit for the disco ceiling lights.

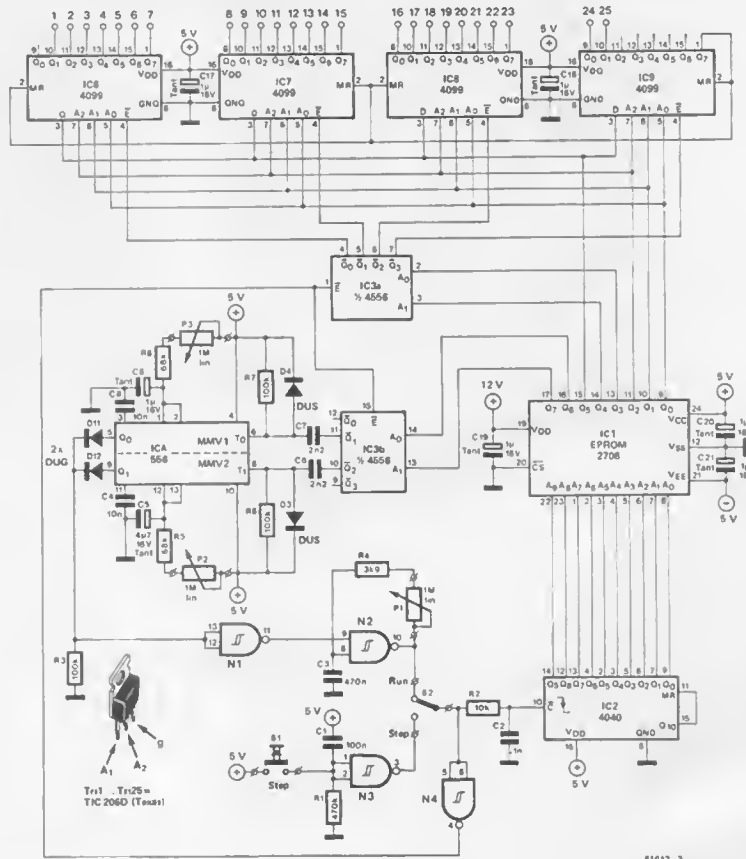
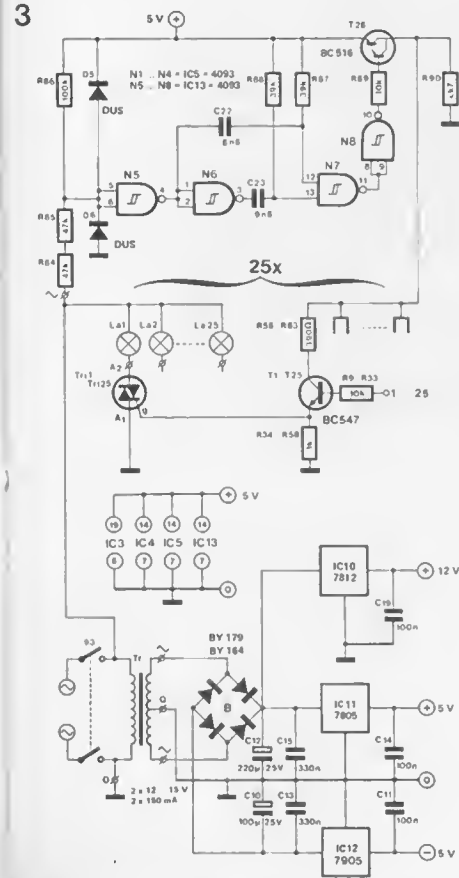

Figure 3. The complete circuit diagram of the lighting control unit.

4

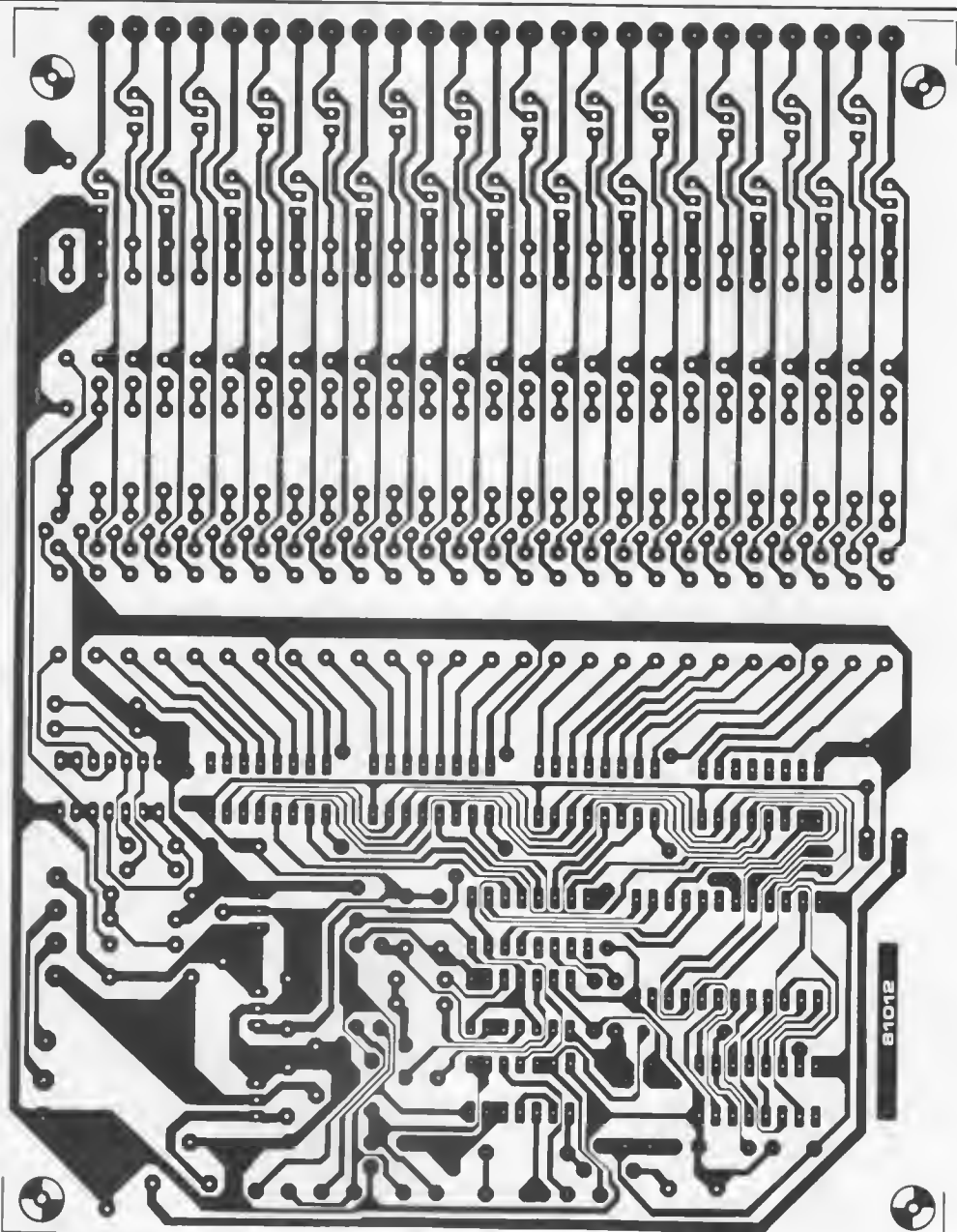

Figure 4. The printed circuit board end components overlay for the lighting control unit. The wire links close to the triacs should be as thick as possible.

Perts list

Resistors:

R1 = 470 k
 R2, R9 . . . R33, R89 = 10 k
 R3, R6, R7, R86 = 100 k
 R4 = 3k9
 R5, R8 = 68 k
 R34 . . . R58 = 1 k
 R59 . . . R83 = 390 Ω
 R84, R85 = 47 k ¼ W
 R87, R88 = 39 k
 R90 = 4k7
 P1 . . . P3 = 1 M lin.

Capacitors:

C1, C11, C14, C16 = 100 n
 C2 = 1 n
 C3 = 470 n

C4, C9 = 10 n

C5 = 4μ7/16 V tantalum

C6, C7 = 2n2

C8, C17 . . . C21 = 1 μ/16 V tantalum

C10 = 100 μ/25 V

C12 = 220 μ/25 V

C13, C15 = 330 n

C22, C23 = 6n8

Semiconductors:

T1 . . . T25 = BC 547

T26 = 8C 516

D1, D2 = DUG

D3 . . . D6 = DUS

Tri1 . . . Tri25 = TIC 206D (Texas)

IC1 = 2708 (EPROM)

IC2 = 4040

IC3 = 4556

IC4 = 556

IC5, IC13 = 4093

IC6 . . . IC9 = 4099

IC10 = 7812

IC11 = 7805

IC12 = 7905

Miscellaneous:

Tr1 = 2 x 12 . . . 15 V/150 mA transformer

B1 = 100 V/0.5 A bridge rectifier (8Y 164, BY 179)

S1 = pushbutton, 240 V

S2 = spst 240 V

S3 = dpst 240 V/13 A

La1 . . . La25 = light bulb (100 W maximum)

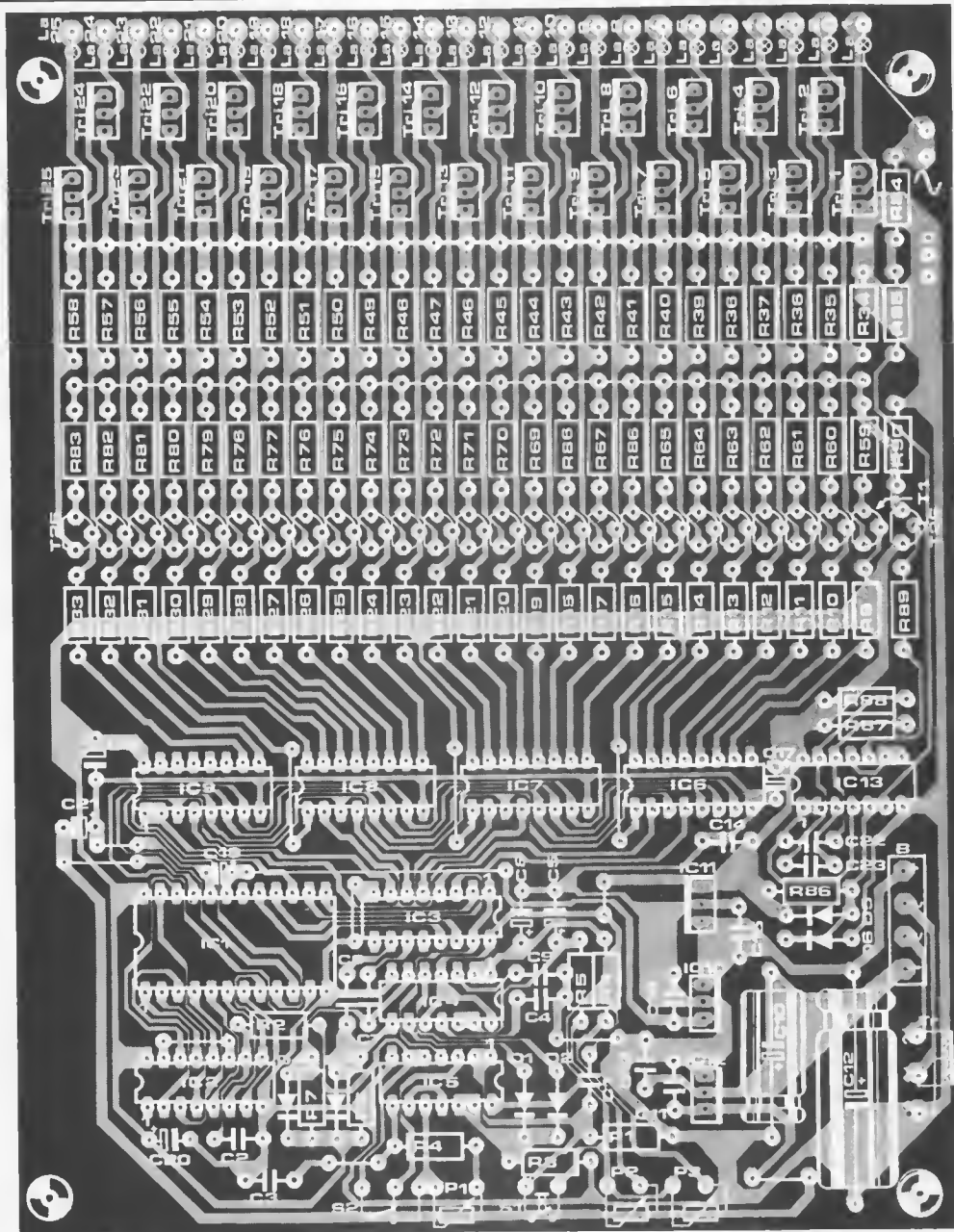

been incorporated into the circuit). The +12 V and -5 V supplies are only required by the EPROM and as the complete circuit draws very little current, the voltage regulators do not require heatsinks.

The program

An explanation of how the EPROM should be programmed was given earlier, however, just to recap: The five least significant bits ($Q_0 \dots Q_4$) determine which of the lamps is to be addressed. The binary value of these bits corresponds to the decimal 'value' of the lamp. The sixth bit (Q_5) determines whether the addressed lamp is to be turned on or off. If Q_5 is high (1)

the lamp will be turned on. If Q_5 is low (0) the lamp will be turned off. The remaining two bits (Q_6 and Q_7) select one of the two possible delay periods via MMV1 and MMV2 respectively. All of the above was clearly shown in table 2. A complete (hexadecimal) listing of the EPROM program is given in table 3. This program will produce all of the display configurations listed in table 1. With all of the information given it should not present too much of a problem for the reader to develop his/her own individual program.

A few practical hints

As mentioned previously, the lighting control circuit is connected directly to

the mains supply. It is therefore imperative that you do not touch any of the components once the circuit has been plugged in!! It is conceivable that there may be a lethal voltage somewhere even on the low voltage section of the circuit. For this reason the completed circuit should be mounted in a completely insulated case. It is also important to ensure that the potentiometers used have plastic spindles.

All the pushbuttons and switches used in this circuit must be rated at 240 V AC at least, even if they only switch 5 volts. We can not emphasise enough that *the low voltage section is directly connected to the mains*. Switch S3 must not only be capable of bearing 240 volts, but it

must also have a current rating of at least 13 A. Note: a household light switch will *not* cope with this amount of current. The wiring of the lamp matrix is another important aspect — only heavy duty wire should be used.

The printed circuit board and component overlay for the lighting control unit is given in figure 4. Mounting the components on the board should not cause any difficulty. As long as the specifications are adhered to (!) there will be no need to use heatsinks on any of the components — not even the triacs.

The wire links closest to the triacs should be made from reasonably thick copper wire (at least 1 mm). This is because they are going to have to cope with a fair amount of current. The common connection of the lamps will also have to withstand a great deal of current ($25 \times 100 \text{ W} = 2500 \text{ W}$, $2500/240 = 10.4 \text{ A}$!).

Finally, a word about the ceiling itself. It should be possible for the average handyman to construct his own. As stated earlier, there is no reason why a wall (or wall mounting) unit could not be constructed also (or instead). This is particularly true if a 'scaled down' version was to be built — using small, low power bulbs instead of the large 'hefty' ones. While on the subject of lamps, it is also possible to use four 25 W ones as opposed to the single 100 W lamp. This would then give a more even distribution of light throughout the (square) section, although four times as many lamp holders would then be required. Why was the word 'square' in parentheses? Why do you need to stick to a square? Virtually any conceivable shape can be used in the construction, such as circles, triangles, hexagonals etc. The concept is limited only by the skills of the constructor.

It should be borne in mind that the lamps will produce a certain amount of heat. Therefore a certain amount of ventilation would be in order. Materials used in the construction should be capable of withstanding any heat generated. Coloured perspex was found to be an excellent diffuser and distributes light very well. Glass is also another obvious possibility but it does tend to be rather expensive — especially when you cut it half an inch too short!! The effects of the lighting display can be enhanced somewhat considerably by incorporating mirrors, or mirrored tiles. No doubt the enterprising reader can think of many other possible applications of the circuit, such as shop window lighting for instance. All in all, an excellent display unit at a very reasonable cost. 

Sound . . . rapid vibrations, travelling through the air, is always present — even if we don't always realise it. However, those who have ever spent some time in a completely sound-proof room will know the difference between 'no sound' and normal background levels.

Sounds can be quite pleasant — music, for instance — or decidedly unpleasant, like a car horn going off unexpectedly just behind you. The difference is not only the type of sound, but also the level. Above a certain level, sounds tend to get annoying. At even higher levels, it actually hurts your ears — and permanent damage may well occur.

measure from 50 to 110 dBA

sound pressure meter

Anybody can tell whether they are in relatively quiet or noisy surroundings. At least you'd think so. Although . . . sometimes you wonder. Human hearing is subjective: what some people consider 'pleasant background music', others would class as 'an abominable row'. For a more objective assessment of the actual sound level, some kind of meter is required.

However, since we are mainly interested in sound as it relates to us, the measurement must also take the average frequency response of our ears into account. The meter described here measures in dBA, over the whole range from normal conversation up to loud disco music.

This is cause for some concern, nowadays. The extremely high levels that are pumped into disco's may give a nice 'high' sensation at the time. However, if your ears are ringing when you step outside after a few minutes, be warned! Prolonged exposure to this kind of abuse can (and often does) cause *permanent* damage to your hearing. And after all, we all hope that our ears will last a lifetime.

Before describing the sound pressure meter itself, let's take a closer look at our own built-in meter: our ears. What can they measure?

We can only hear sound within a certain frequency range — broadly speaking, between 20 Hz and 20 kHz. There is some controversy about the actual limits, but that's not so important in this context. Whether the upper limit is 20 kHz, 10 kHz or only 7 kHz is partly a question of age, and below 20 Hz sound may possibly be 'felt' — but it is not really 'heard'. However, who said electronics was an accurate

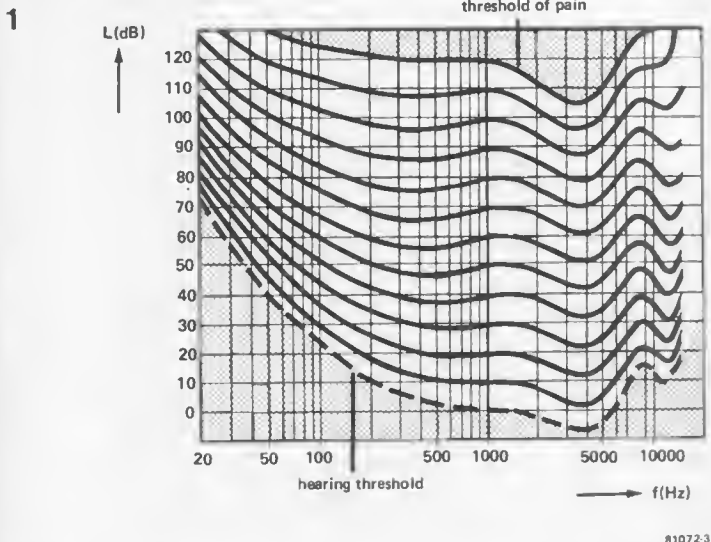

Figure 1. This graph illustrates the degree of sensitivity of human hearing. The lines of equal loudness, isophones, indicate at what volume a given frequency must be for it to sound as loud as a 1000 Hz tone.

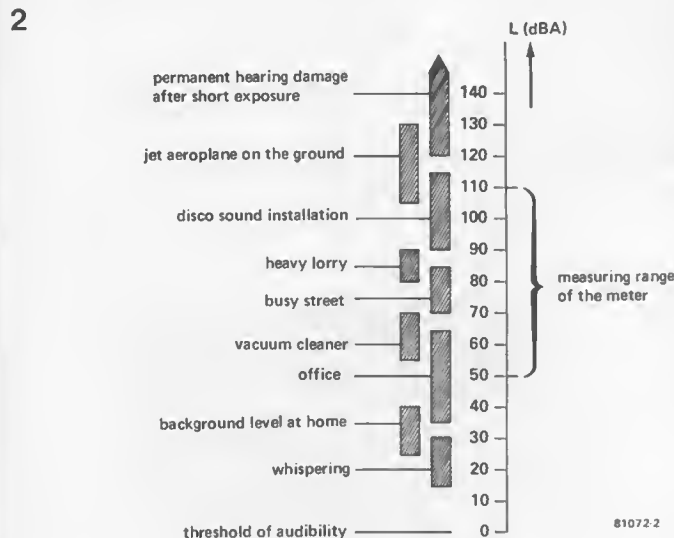

Figure 2. Examples of loudness values expressed in dBA.

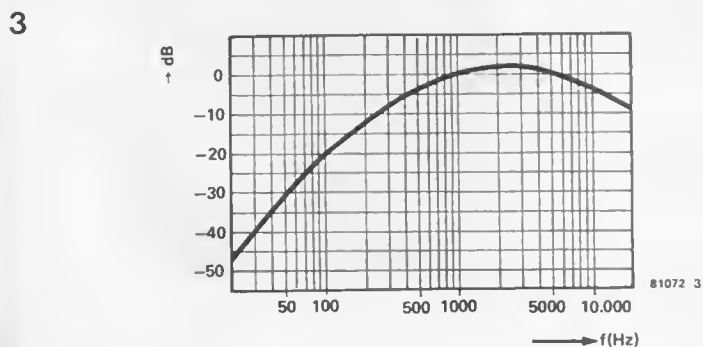

Figure 3. The characteristics of the A weighted curve.

science? When designing a sound pressure meter, 'somewhere between 20 Hz and 20 kHz' is a sufficiently accurate definition for the limits.

For sound to be audible, it must not only be within the correct frequency range. Loudness is also important, and the minimum level that we can hear varies with frequency. Our ears are most sensitive in the 500 Hz to 5 kHz range, as shown in figure 1. For a 100 Hz and a 1 kHz tone to 'appear' equally loud to us, the former must actually be at a much higher level than the latter - certainly at low levels.

This is all clearly shown in the plots given in figure 1. The lower dotted line is the hearing threshold: sounds below this level are inaudible. From the scale at the left it can be seen that this corresponds to 0 dB at 1 kHz (no coincidence, that), and to 40 dB at 50 Hz. Quite a difference! The higher lines all correspond to equal (apparent) loudness, as a function of frequency. The highest line is marked 'threshold of pain'. This is rather misleading, unfortunately: it suggests that everything is perfectly all right up to this level. Not so! Prolonged exposure to much lower levels (30 minutes at 100 dB, for instance) can already lead to permanent damage. The only point about the actual threshold is that it really hurts, and damage is likely within a very short time indeed.

A lot more could be said about these plots, but there are several good books on the subject. Theory is one thing, but there is nothing like practical examples. In figure 2, several well-known sounds are plotted on a sound level scale. This is calibrated in dBA, as in common practice. But what is a 'dBA', exactly?

If we want to measure sound levels as we relate to human hearing, we must obviously 'weigh up' the results to match the characteristics shown in figure 1. An 'objective' sound level of 60 dB at 100 Hz, say, must give the same 'loudness' result as 50 dB at 1 kHz. Obviously, it would take some doing to build a circuit that accurately follows all plots at all levels. Fortunately, there is no need for that kind of accuracy, and according to international standard a single fixed frequency compensation can be used. This is the so-called A-weighting curve, shown in figure 3. Sounds picked up by a microphone are passed through a filter with this response, and the level is measured behind the filter. The result is expressed in dBA.

Measuring sound in dBA

By now we've got a reasonable idea of what we need to measure sound pressure in a useful way. Obviously, since we want to measure sound, we will need a microphone with a reasonably flat response. Some kind of capacitor microphone would be ideal.

4

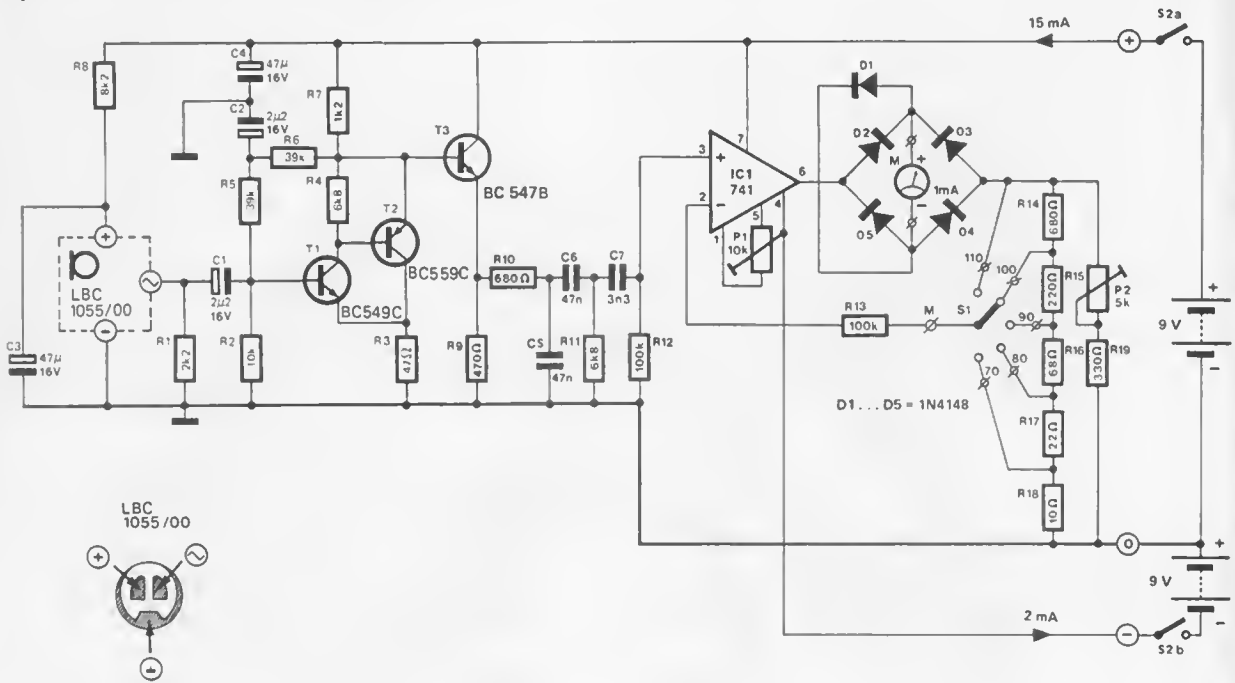

81072-4

Figure 4. The sound pressure meter circuit consists of a microphone, an amplifier, a filter and an AC voltmeter with range switch.

5

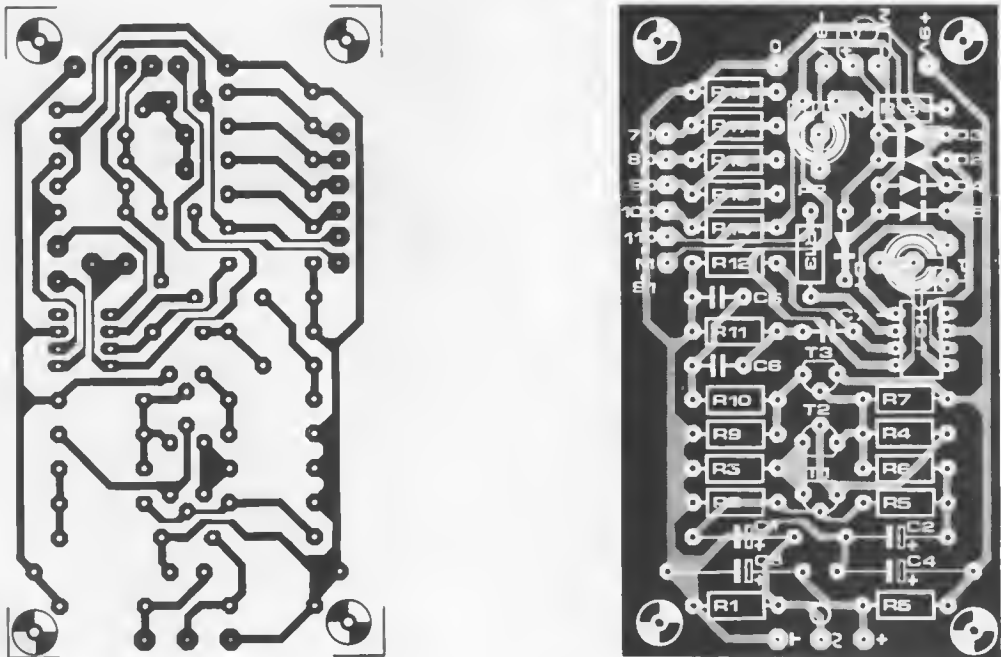

Figure 5. The printed circuit board with component overlay for the sound meter.

Then, a microphone preamplifier of course — you can hardly expect to drive a pointer instrument from the microphone output! This preamp must be followed by the A-weighting filter mentioned above; the output from the filter is fed to an AC measuring circuit, that indicates the level in dB.

The circuit described here will measure in the 50 dBA to 110 dBA range. It is apparent, from a brief look at figure 2, that this is quite adequate for normal use. Below this level, you're in the background noise. And above it? You shouldn't be there in the first place!

Within the range, you can compare the output level from two loudspeaker systems: measure your neighbour's car as he goes past, to find out whether he really needs a new exhaust pipe; or compare the noise produced by a jet aircraft overhead to that of your own little model aeroplane.

The circuit

The complete circuit is shown in figure 4. A good choice for measuring microphone is the Philips electret type, LBC 1055/00. Basically, this is a capacitor microphone without the need for a special high-voltage supply. It has an FET buffer stage built in, so that its output is at quite a low impedance. Its frequency response is virtually flat from 100 Hz to 14 kHz, and it doesn't run into overload until the level exceeds 134 dB . . .

The FET in the microphone needs a positive supply, and this is derived via R8 and C3. The actual microphone signal is amplified by T1 and T2. The gain of this stage is approximately x20 — determined by the ratio between R7 and R3. Both the input impedance (determined by R1) and the gain are chosen to suit this type of microphone. If some other type is to be used, some modifications may be required here.

The amplifier signal is passed through an emitter follower (T3) to the A-weighting filter, consisting of R10 . . . R12 and C5 . . . C7. This filter gives a reasonable approximation of the desired frequency response shown in figure 3.

The final stage is the actual meter circuit. IC1, together with the diode bridge, a 1 mA moving-coil pointer instrument and assorted feedback resistors, makes a very good AC voltmeter. Diode D1 is included to protect the meter itself from overload. The desired measuring range is selected by means of S1. Effectively, the voltage across the divider chain (R14 . . . R18) is proportional to the current through the meter, and when the feedback is taken off from a lower point in the chain this will correspond to a lower input voltage required for full scale deflection.

The actual meter used is a relatively 'sluggish' (heavily damped) 1 mA type — as used for tuning indication, for



81072-6

Figure 6. A scale in dB's for the moving coil meter. The lower scale (from 0 to 1) is the original mA scale.

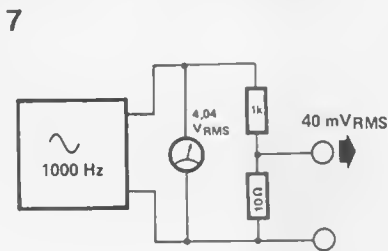

81072-7

Figure 7. This auxiliary circuit is used to calibrate the meter.

Parts list

Resistors:

- R1 = 2k2
- R2 = 10 k
- R3 = 47 Ω
- R4, R11 = 6k8
- R5, R6 = 39 k
- R7 = 1k2
- R8 = 8k2
- R9 = 470 Ω
- R10, R14 = 680 Ω
- R12, R13 = 100 k
- R15 = 220 Ω
- R16 = 68 Ω
- R17 = 22 Ω
- R18 = 10 Ω
- R19 = 330 Ω
- P1 = 10 k preset
- P2 = 5 k preset

Capacitors:

- C1, C2 = 2μ2/16 V
- C3, C4 = 47 μ/16 V
- C5, C6 = 47 n
- C7 = 3n3

Semiconductors:

- T1 = BC 549C
- T2 = BC 559C
- T3 = BC 547B
- D1 . . . D5 = 1N4148
- IC1 = 741

Miscellaneous:

- Electret microphone LBC 1055/00 (Philips)
- M = 1 mA moving coil meter.
- S1 = single-pole five-way switch
- S2 = double-pole on/off switch

instance. A more sensitive instrument can also be used, provided a suitable shunt resistor is included in parallel, to bring the total sensitivity to 1 mA f.s.d. A suitable scale is shown in figure 6.

There should be no problems with the construction; a printed circuit board layout is given in figure 5. The connections to the microphone are included in figure 4.

Calibration

There are two calibration points in the circuit: P1 is used to compensate the offset of IC1 and P2 calibrates the actual meter.

The first step is the offset compensation. Put in simple terms: with no input signal present, the meter should read zero! The adjustment procedure is as follows. Disconnect the microphone (otherwise it may be damaged!), short R1 and switch S1 to the most sensitive range (70 dB f.s.d.). Set P2 to the centre position, and adjust P1 until the meter just rests at 0.

Now to calibrate the meter. This is more awkward. The best way is to calibrate it against a reference sound source, or by comparing the reading with that of a properly calibrated sound pressure meter. However, we assume that relatively few of our readers will have access to this kind of equipment.

There is another way — less accurate, but good enough for most applications. Manufacturers specify the output from their microphones at some reference level. For the LBC 1055/00, it can be calculated from the manufacturer's data that the output at 110 dB should be 40 mV (RMS). This is rather a low value to set accurately at the output of a tone generator but using two resistors, as shown in figure 7, will solve that problem. The microphone remains disconnected for the time being; instead, the output from the test circuit given in figure 7 is connected across R1.

With the output from the tone generator set to 4.04 V at 1 kHz, we now have the desired 40 mV reference input to the meter circuit. Switch S1 is turned up to the 110 dB range, and P2 is adjusted until the meter reads 0 dB.

One final word, regarding the power supply. We deliberately opted for batteries, so that the unit is portable. A mains supply would be possible, but it's rather clumsy. With the low current consumption involved, batteries will last quite long enough! ✻

200 watts into 4 ohms

raw power

For high sound levels, you need big loudspeakers and a hefty power amplifier. The unit described in this article delivers a good 200 W into a 4 Ω load — sufficient for even open-air use. The most important criteria for disco and electric guitar amplifiers are: high output power, rugged construction and high reliability. There is no call for a frequency response that is flat up to the megahertz range, or for distortion figures that depend more on the resolution of the measuring equipment than on the amplifier itself. The circuit described here is designed with these aims in mind. It gives quite good quality, but a favourable watts-per-pound ratio was considered more important than achieving the highest possible hifi standards.

A few tens of watts, in combination with high-efficiency speakers, is enough to blow your ears out in a living room. You certainly don't need 200 W there. In a hall or in the open air it is a different story — several hundred watts may well be needed to achieve the desired sound level.

The main problem when designing a 200 W amplifier is the output stage. The output transistors, in particular. For this type of output power, a high supply voltage is required; this, in turn, means that you need 100 V transistors at least. Add to this the fact that the output current will be in excess of 10 amps, and you've got problems. To limit the choice still further, a low saturation voltage is required for maximum output swing.

Scanning the data books, it is not too difficult to find complementary transistor pairs that meet all of these requirements, and more. Unfortunately, they all tend to be rather expensive — and difficult to obtain. A cheaper alternative is to use several smaller output devices, connected in parallel. Six in all, in this particular circuit.

The circuit

A true complementary class-B output stage is used, as shown in figure 1. The upper half of the output stage consists of three transistors in parallel (T9, T11 and T13); the lower half contains a complementary set (T10, T12 and T14).

Each output device has its own emitter resistor. This performs three functions. In the first place, including these resistors ensures that the output current is distributed evenly over the three transistors in the 'active' half. The point is that it is virtually impossible to find three power devices with the same 'slope' (collector current as a function of base-emitter voltage). If all three transistors simply had their bases and emitters tied together, they would all be set at the same base-emitter voltage. The one with the highest slope would then proceed to deliver the bulk of the output current. After a very short time, it would pass over to that big silicon valley in the sky, where all good transistors go. The voltage drop across the emitter resistors is a measure of the output current. This means that it can be used for current limiting. The three voltages in the upper half are 'summed' by R14, R18, R22 and R27, and used to drive a current-limiting transistor (T5). When the voltage across R27 rises to about 0.65 V, T5 will conduct via D1, thus limiting the drive to T7. With the values given, the peak output current is limited to approximately 14 A — a safe value, since the transistors can withstand peak currents of up to 40 A! For those who like to try a new gimmick, D1 and D2 can be replaced by LEDs. These will light up when the amplifier is driven into clipping.

The third function performed by the emitter resistors is — as in most power amplifier designs — to stabilise the quiescent current through the output devices.

The input stage

A rather uncommon feature is the use of an IC as the input stage. The CA 3130 is a fast opamp with MOSFET inputs.

The output voltage from the opamp is passed to T4; in combination with R10, this transistor effectively converts the signal voltage into a drive current. The collector load for this transistor is a current source (T1, T2 and T3) that is set at a constant current of approximately 30 mA. This combination of current sources 'at top and bottom' makes for rapid switching capability — leading, in turn, to a high slew rate for the amplifier. The 220 Ω preset (P2) sets the bias current through the output stage.

A closer look at the circuit will bring to light that there is no local feedback around the input opamp. This makes for a very high overall open-loop gain: some 320,000 times, equal to 110 dB! The main feedback loop consists of R2 and R5. These two resistors set the overall closed-loop gain to 33; this means that the amplifier is fully driven with an input signal of 850 mV. If a higher or lower input sensitivity is required, the value of R2 can be modified accordingly. However, to avoid stability problems, it should not be reduced below about 1 k.

The supply for IC1 is zener-stabilised by D3. A DC input bias voltage is derived from this supply, by means of R3, R4 and P1. This bias voltage determines the DC voltage at the output (R24/R25 junction). P1 should be adjusted so that the voltage at this point (positive end of the output electrolytic) is equal to half the supply voltage.

Capacitor C3 in the feedback loop is included to roll off the frequency response at higher frequencies. With the value given, the frequency response is 3 dB down at 60 kHz.

Construction

A suitable p.c. board layout is given in figures 2 and 3. For obvious reasons, not all components are included on the board.

The output electrolytic and resistor R26 are mounted at some suitable point in the case. The output transistors T9...T14 and the drivers T7 and T8 must be mounted on a heatsink with a thermal coefficient of 0.5°K/W, or on two smaller 1°K/W heatsinks. For those who don't know about thermal coefficients: you need BIG heatsinks.

T1 and T2 are also mounted on the heatsink. Not to cool them, but to heat them up! Two 5.5 mm holes are drilled in the heatsink, about four inches apart,

Table 1

Specifications:	
Power supply:	95 V/3.5 A
Efficiency:	60% (max.)
Output power:	200 W into 4 Ω (sinewave) 100 W into 8 Ω (sinewave)
THD:	max. 1% at 200 W; \leq 0.2% at 50 W
Frequency response:	10 Hz... 60 kHz (−3 dB)
Input sensitivity:	850 mV for full drive
Input impedance:	3k3

1

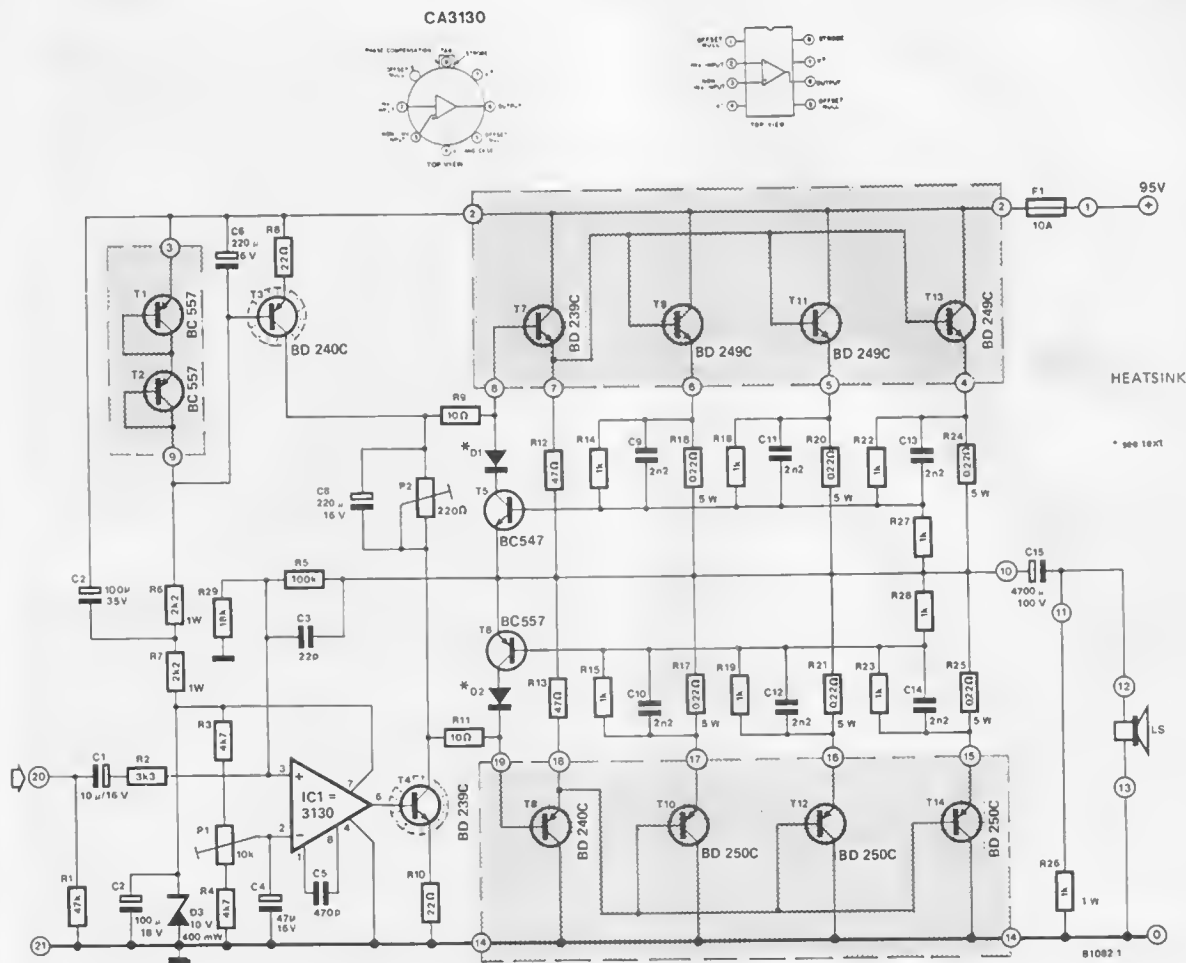

Figure 1. The complete circuit.

and filled with heat-conducting paste. With T1 and T2 inserted in these holes, they tend to follow the case temperature of the output devices, providing effective thermal stability for the amplifier.

In the prototype, the heatsink was 18 x 15 cm in size (about 7" x 6"), with 5 cm high cooling fins. It was actually used as the rear wall of the case.

The power transistors must be connected to the board by means of thick wires — 1 mm diameter, at least. Car electrical system gauge, or the type used for house wiring. Furthermore, the board should be mounted as close to the heatsink as possible, to keep the wiring length to a minimum.

A word of caution, regarding IC1. This opamp contains MOSFETs, and as such it is sensitive to static charges. It should normally be supplied with its pins inserted in conductive foam or in aluminium foil. Leave it that way, until the rest of the amplifier is completed. Then, if you want to play it completely safe, thread bare copper wire between the pins of the IC (shorting them together) before removing it from the foam; insert

it in its socket on the board and only then remove the copper wire.

Power supply

A high-power amplifier needs a high-power supply. Fortunately, there is no need to stabilise it. Two versions are shown in figure 4, one using a normal 66 V mains transformer and the other with a centre-tapped secondary. The choice is not really determined by the type of mains transformer that is available: the electrolytics are more of a problem. 10,000 μ F/125 V is not a particularly common type, by any standard; 63 V types are definitely more easy to come by. Furthermore, you need really first-class heavy-duty electrolytics (this also applies to the output electrolytic, C15): at full drive, 10 A AC is flowing through these capacitors. If they're too small, physically, they tend to explode...

The bridge rectifier should be one with a metal case, that can be bolted down onto a heatsink.

Adjustment procedure

Setting up a power amplifier is a fairly

simple job. However, in an amplifier of this type mistakes tend to be rather expensive, so we will describe the whole procedure step-by-step.

1. Check all wiring between p.c. board, power transistors, supply, electrolytics etc. All clear? Then:
2. Using an ohmmeter, check that the metal cases of all transistors are properly insulated from the heatsink. You forgot to include mica washers? That's a nuisance, you do need them.
3. P1 is set to the mid-position, and P2 is turned to minimum resistance.
4. Remove the 10 A fuse in the main supply line.
5. Plug in to the mains, and check the voltage across the supply electrolytic(s). This should be approximately 95 V. OK? Pull out the plug again.
6. Connect a 245 V/100 W mains filament lamp across the 10 A fuse holder — effectively, this lamp temporarily replaces the fuse.
7. Plug in, and measure the voltage at the positive side of C15 (R24/R25 junction). Adjust P1 until this point is set at 45 V. Note that when you first switch on, the lamp should light up briefly and then go out and stay out.

2

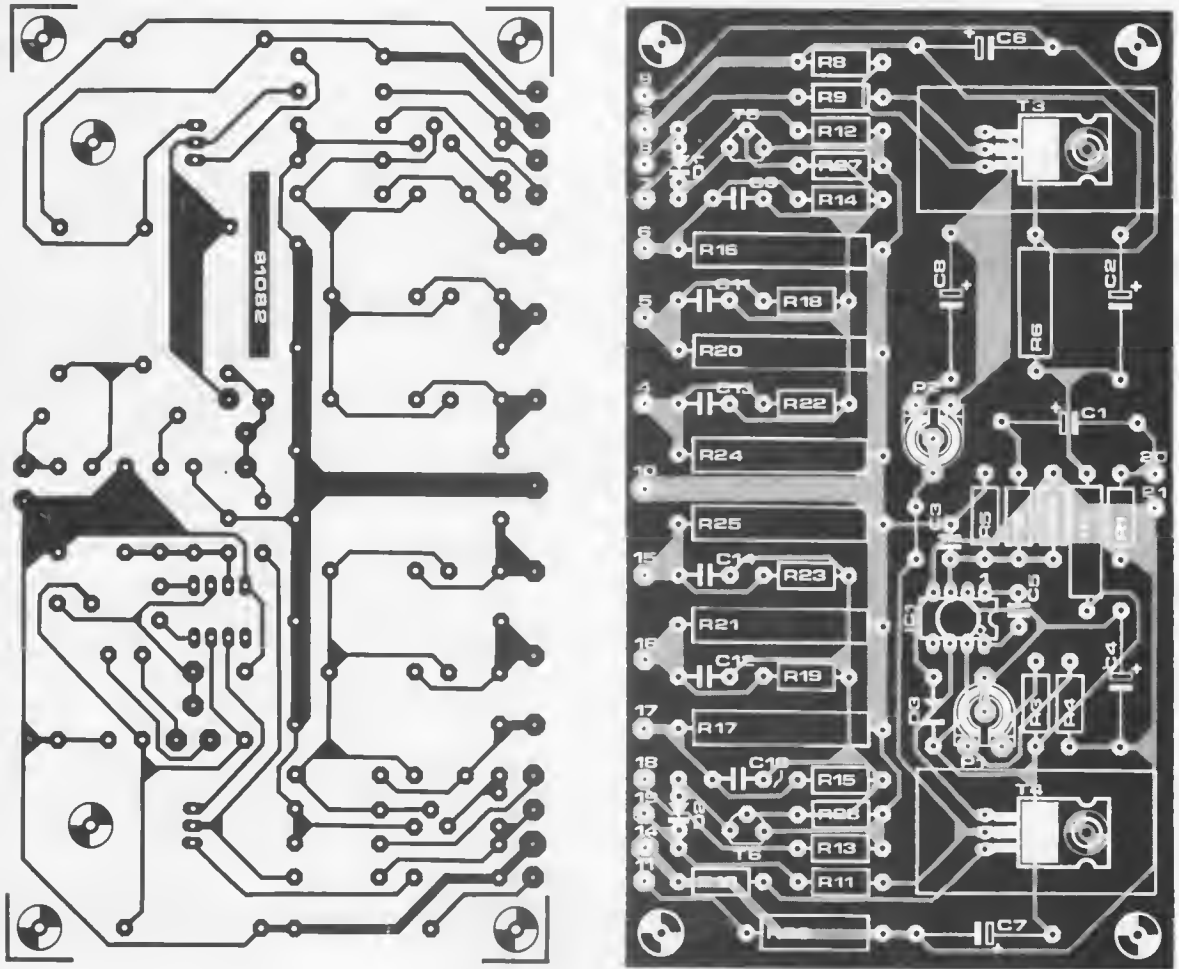

Figure 2. Printed circuit board layout. Particular care should be taken when mounting IC1, as explained in the text.

Parts list

Resistors:

R1 = 47 k
 R2 = 3k3
 R3, R4 = 4k7
 R5 = 100 k
 R6, R7 = 2k2/1 W
 R8, R10 = 22 Ω
 R9, R11 = 10 Ω
 R12, R13 = 47 Ω
 R14, R15, R18, R19,
 R22, R23, R27, R28 = 1 k
 R16, R17, R20, R21,
 R24, R25 = 0.22 Ω /5 W
 R26 = 1 k/1 W
 R29 = 18 k
 P1 = 10 k preset
 P2 = 220 Ω preset

Capacitors:

C1 = 10 μ /16 V
 C2 = 100 μ /35 V
 C3 = 22 p
 C4 = 47 μ /16 V
 C5 = 47 p

C6 = 220 μ /6 V
 C7 = 100 μ /16 V
 C8 = 220 μ /16 V
 C9... C14 = 2n2
 C15 = 4700 μ /100 V (see text)

Semiconductors:

D1, D2 = 1N4148 or red LED (see text)
 D3 = 10 V/400 mW zener diode
 T1, T2, T6 = BC 557
 T3, T8 = BD 240C, TIP 42C
 T4, T7 = BD 239C, TIP 41C
 T5 = BC 547
 T9, T11, T13 = BD 249C, TIP 35C,
 MJ 80
 T10, T12, T14 = BD 250C, TIP 36C,
 MJ 4502
 IC1 = CA 3130

Miscellaneous:

8-pin DIL IC socket
 2 cooling fins for T3 and T4
 1 heatsink, 0.5°K/W
 or two 1°K/W heatsinks)
 mica washers for T7... T14
 10 A slow-blow fuse with fuse holder

Parts list for the power supply

Version 1:

C16 = 10,000 μ /125 V (see text!)
 B = 80 V/10 A bridge rectifier
 Tr = 66 V/6 A mains transformer

Version 2:

C17... C20 = 10,000 μ /63 V (see text)
 B = 80 V/10 A bridge rectifier
 Tr = 66 V/6 A mains transformer
 with centre-tapped secondary

If this is not the case, either P2 is not set to minimum or there is a fault in the circuit.

8. If everything is OK so far, the next step is to short the input. Then: switch off; remove the filament lamp; connect an ammeter (at least 1 A f.s.d.) across the fuse holder. The supply side is '+', the amplifier end is '-'.

9. Switch on again. The needle will kick up briefly, after which it should swing back to indicate approximately 35 mA. Turn up P2 until this DC bias current reaches 150 mA.

10. Again check the voltage at the positive side of C15. This should still be 45 V. If so, everything is working as it should. You can now switch off, remove the meters and the short across the input and replace the fuse. That's it! You can now try it out with music. 

3

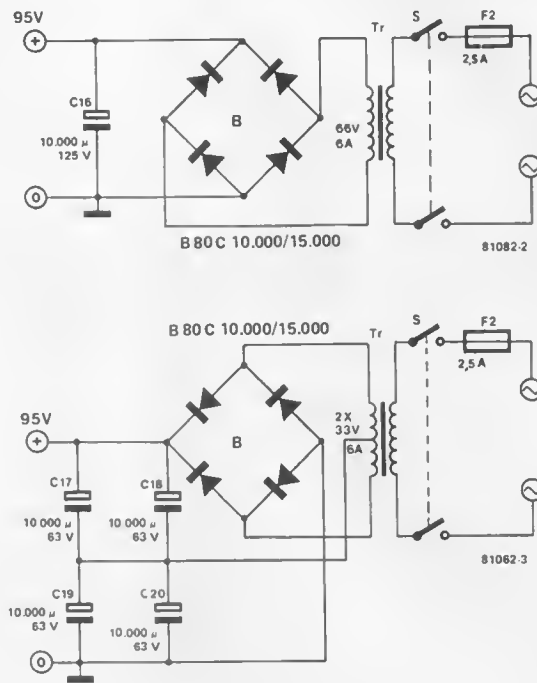

Figure 3. Two possible power supply circuits. The choice is determined mainly by the type of electrolytics available.

4

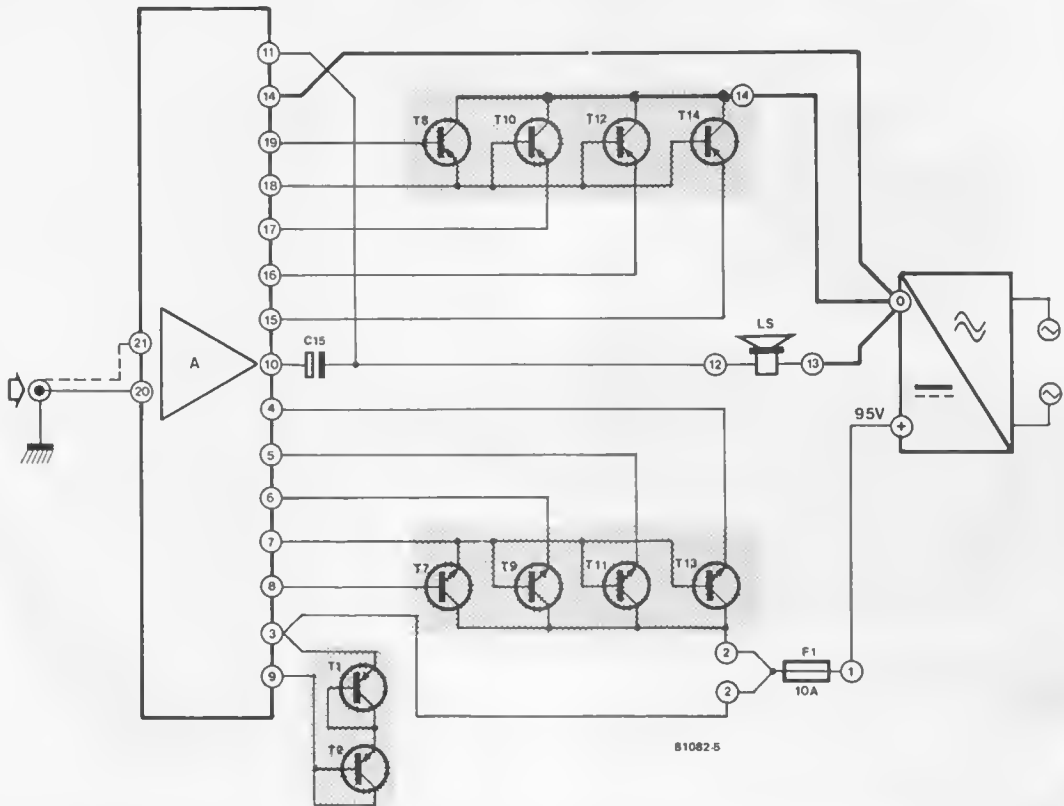

Figure 4. Wiring diagram. Note that fairly thick wire should be used for all connections to the output devices and loudspeaker.

a good mixer can be simple

mini mixer

There are all kinds of mixing desks. Little ones, like in tape recorders: two knobs, one for the mike input and one for 'line'. At the other end of the scale are the big professional mixing consoles, as used in professional recording studios. More than two knobs are usually required in that sort of application.

For amateur use — both for tape recording and for use in sound installations — a number of channels may be required, but the total cost must remain within the available budget. There is no need for highly sophisticated electronics, the only requirement is that it works well and reliably, and that it provides all necessary controls.

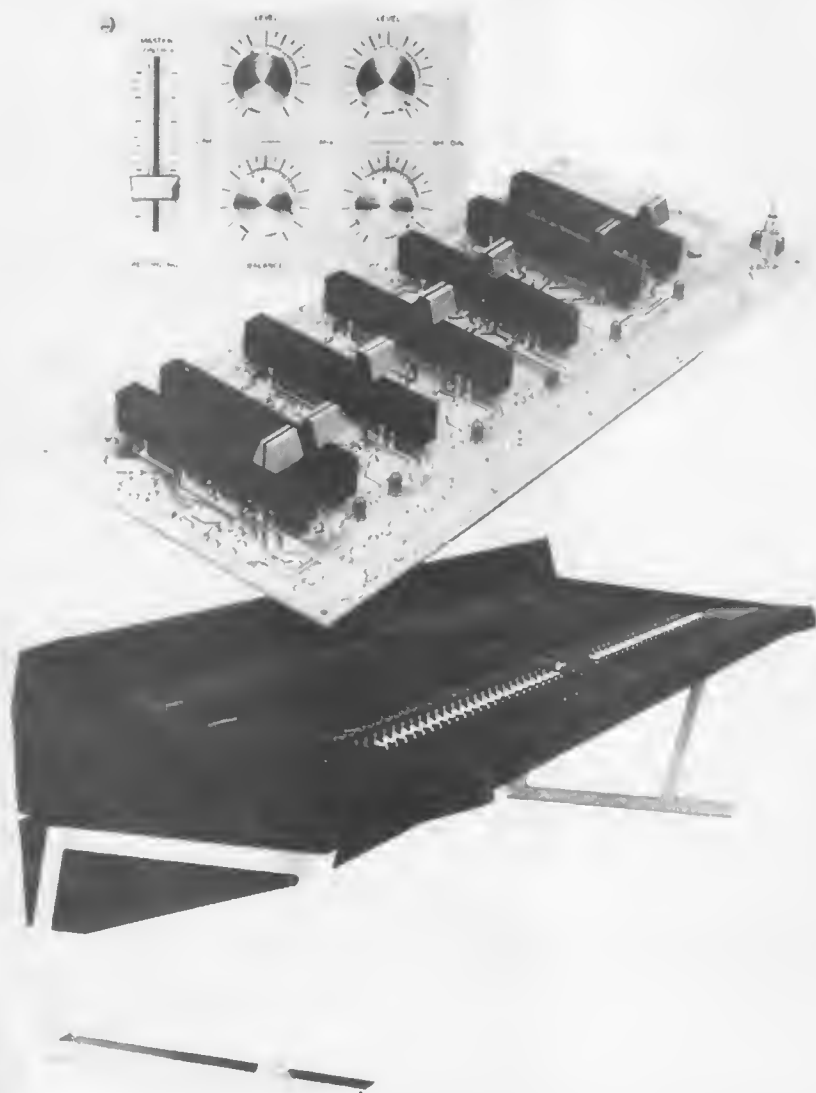

A simple mixing desk, therefore, but a good one. Reliable, easy to build, no 'peculiar' components and relatively easy to extend as required. In a nutshell, these are the design requirements for the 'mini mixer'.

What do you need?

Obviously, if you are aiming at a minimum-cost design — initially, at any rate — the first question that must be answered is: which functions are essential? Equally obviously, it is a good idea to bear possible future extension in mind from the outset. It would be a great pity if a desirable extension at a later date proved impossible, because of some oversight in the initial design!

What inputs?

Even the simplest of mixing desks must have inputs for microphone(s), record player(s) and tape. Which leaves the questions: how many? And: what type? One microphone input is often sufficient, but two make it much easier to convert to stereo at a later date. So, let's settle on two. For the present, the outputs can be mixed into both output channels for mono microphones. A mono/stereo switch and/or 'pan pots' (more on these later) can always be added later. One final question: what input sensitivity? This is not really as critical as you might think. For most modern mikes, about 2 or 3 mV is a good value.

Next: record player. In this case, two stereo inputs are essential. For 'non-stop' music, the next record is placed on the turntable in readiness to take over as soon as the current record ends. This calls for two turntables, which means there must be two inputs! The actual type of input is also an obvious choice. Nowadays, we can forget crystal cartridges, and moving-coil cartridges are normally used in conjunction with a separate pre-preamplifier, that is intended for driving a dynamic ('MD') input. Which means that 'dynamic' inputs are sufficient.

A tape input? Well — why not. It doesn't cost much, and it can prove quite useful. Pre-recorded cassettes are often almost as good as records. Furthermore, this type of input can be a great help when putting together a sound track for film or slides, with the aid of two tape recorders. For that matter, the very fact that a tape input will normally also work as a 'tape output' makes it almost a must. How else do you use the mixing desk for recording?

What controls?

A level control for each input — that is the very least a mixing desk must have! Tone controls? Given present-day record, tape and microphone quality, tone controls for each input are rather an unnecessary luxury. Even their use for the common output signal is questionable. Use is normally restricted to

Specifications

Inputs:	sensitivity*	input impedance	maximum input level
Tape	150 mV	2M Ω	310 mV
Dynamic cartridge (2)	3 mV	47 k	6.5 mV
Microphone (2)	2.7 mV	3k Ω	5.7 mV

* RMS input level for 775 mV output at 1 kHz

Outputs:
 Main output: maximum output level: 1.6 V RMS
 output impedance: 220 Ω
 Monitor output: nominal output level: 420 mV
 output impedance: 90 k Ω

Tone control:
 Treble: \pm 14 dB (10 kHz)
 Bass: \pm 10 dB (100 Hz)

Frequency response:
 20 Hz . . . 25 kHz (3 dB)

Distortion:
 < 0.1%

Power requirement:
 12 V/400 mA (max)

setting up the desired 'boom and tish' levels. Tone controls for this particular application should concentrate mainly on the extreme bass and treble ends. No problem: selecting the correct turnover frequencies is a matter of resistors and capacitors.

A common output level control? This isn't really necessary, unless several inputs are to be mixed *simultaneously* - 'true' mixing in other words, as opposed to 'fading' from one input to the other. In most practical applications, a 'master' volume control is redundant (for that matter, it is often already present on the power amplifier). Similar reasoning leads to the conclusion that level presets for each individual input are not strictly necessary either. The main level controls for each channel will do the job. In some cases, admittedly, it can be useful to preset each input so that 'full drive' corresponds to sliding the corresponding fader right up. Therefore, the design must offer the possibility of adding

1

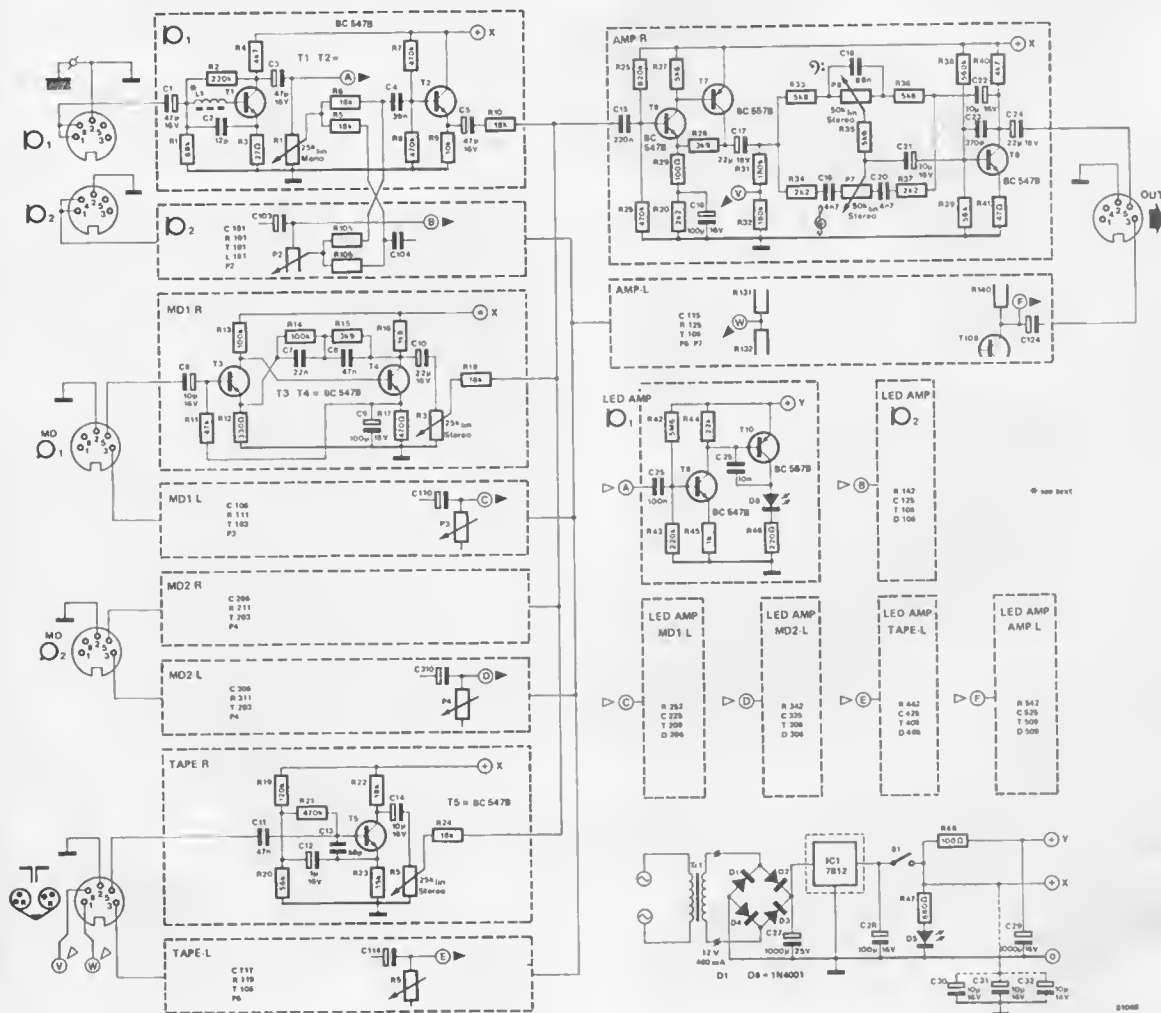

Figure 1. The modular approach to the construction of the mixer becomes apparent in the circuit diagram.

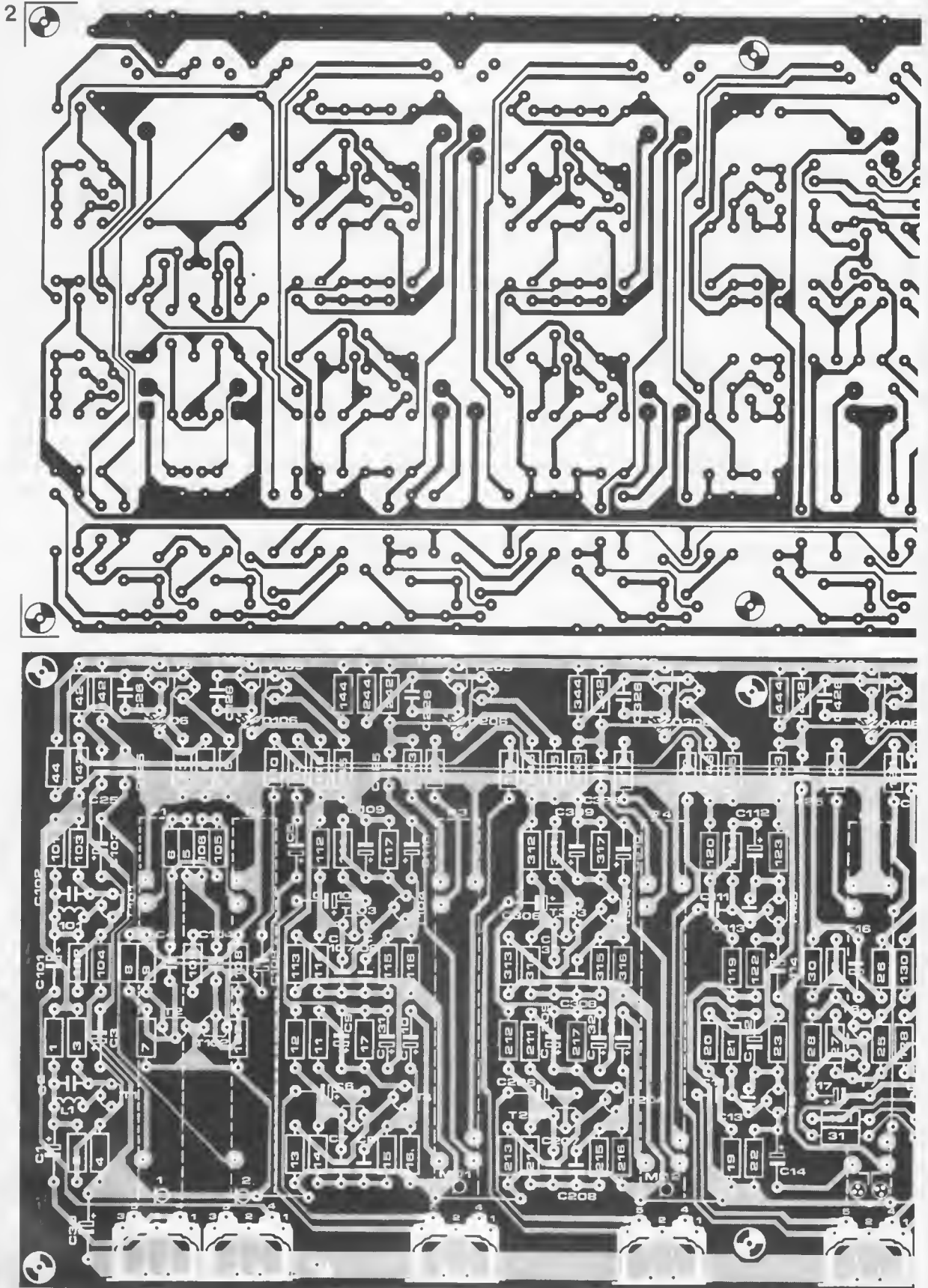
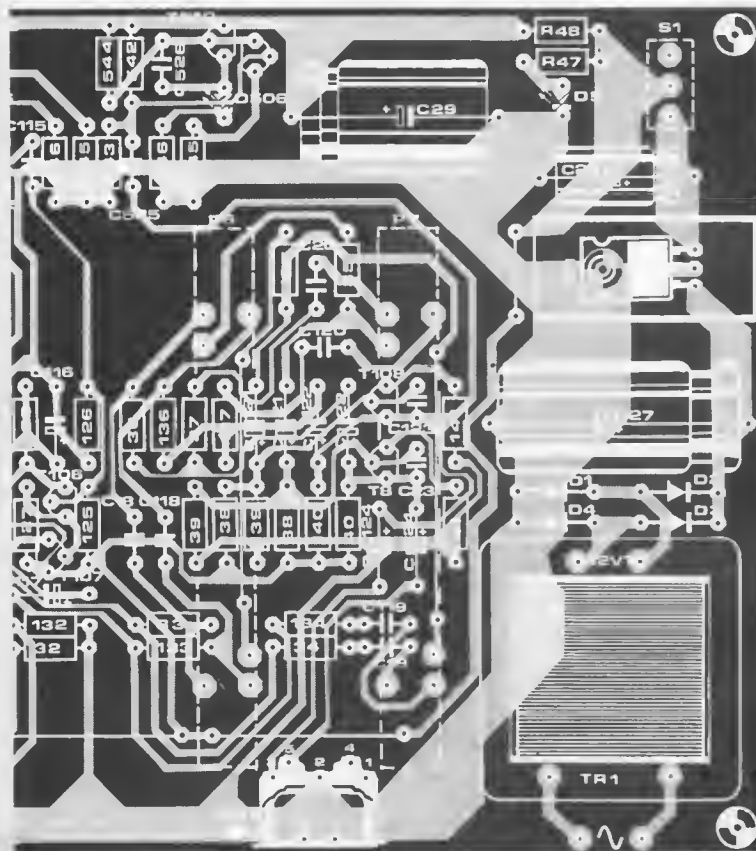
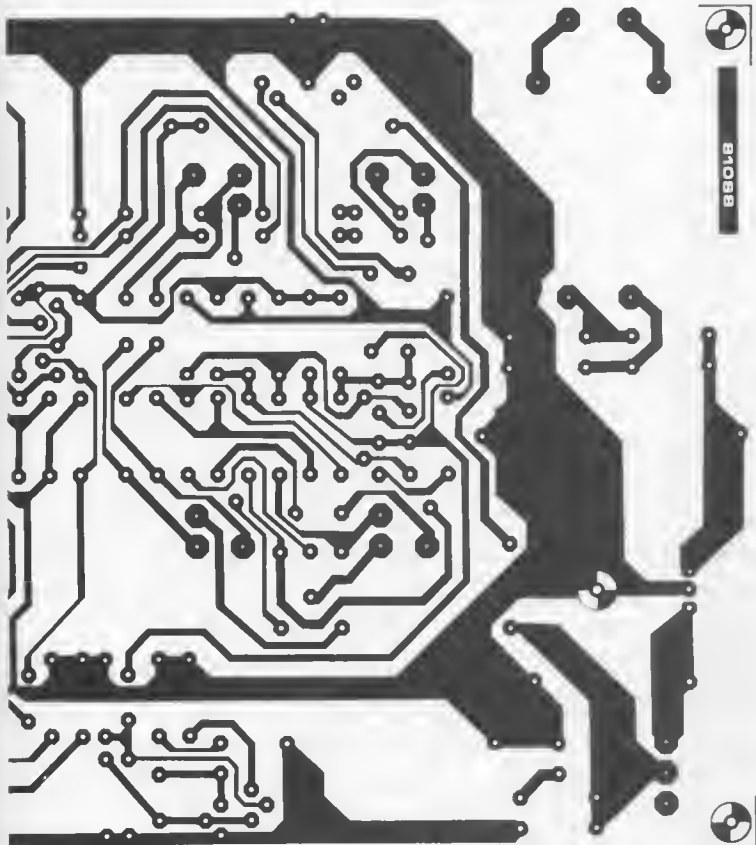

Figure 2. The printed circuit board and component overlay for the mini mixer.



Note that, due to lack of space, it is shown reduced to 90% (scale 1 : 1.1)!

preset adjustments if desired.

What else? All kinds of 'gimmicks' could be considered: on/off switches for the various inputs; mono/stereo switches, 'pan pots'; balance controls; tone controls and filters per channel; etc. But are they necessary? Not really.

One final question: what type of controls? As anybody with practical experience knows, reliable slider potentiometers are by far the best. Round knobs work, but they're awkward.

What else?

A simple mixing desk obviously doesn't need all kinds of flashing lamps and swinging pointers. They can be fun, admittedly. The best recipe is: add to taste. A large assortment of VU meters, LED indicators, and the like have been described in *Elektor* over the last few years. Most of these can be added to the 'mini mixer' with a minimum of effort. One useful feature is a 'signal indicator' for each input. The simplest version consists of a single LED that lights up as soon as a signal is present at that input. It gives no indication of signal level, in other words; however, it does give a very clear indication that the cables are plugged in and that the tape or record is running.

The circuit

At the outset, we stated the basic requirements for this design: reliability, easy to construct, suitable for later extensions and without 'peculiar' components. A brief look at the circuit (figure 1) is enough to prove that the last of these requirements is certainly met: standard transistors are used throughout. The unit is also reliable and easy to build; the one or two points worthy of special note will be dealt with later. Suitable for further extensions, at a later date? This will become apparent as we take a closer look at the various sections of the circuit.

Microphone inputs

Each microphone preamp uses two transistors. The first of these gives considerable gain ($\times 100$), and the second is used as an output buffer.

The actual input stage (T1) is quite straightforward. The only point to watch is its stability: it's supposed to be an amplifier, not a high-frequency oscillator! This is the reason for adding C2 and L1. The latter, by the way, is nothing spectacular: five turns of enamelled copper wire on a small ferrite bead.

If necessary, the input sensitivity can be tailored for a particular type of microphone. One way is to add a preset potentiometer (10 k) between the input and C1 (the pot is connected between input and supply common, with the wiper connected to C1). Alternatively, a fixed resistor can be added in series with the upper end of P1.

After the main level control (P1), there

are several options. The basic version is given in the circuit: the outputs from both preamps are fed to both output channels, via R5, R6, R105 and R106. Mono, in other words. To obtain a stereo microphone input, R5 and R105 must be removed; to get the best of both worlds, a mono/stereo switch can be added in series with these resistors.

A so-called 'pan pot' can also be included at this point. This type of control allows you to mix in the signal from a mono microphone, and locate it at any desired point in the stereo image. This is termed, appropriately enough, 'panning'. Admittedly, to do the job properly you should ensure that the total output level is relatively independent of the setting of this control, but a very simple system is already quite useful. To add a control of this type, R5 and R6 are removed. Between the free ends of C4 and C104, a series connection of a 5k6 (fixed) resistor, a 25 k lin potentiometer and a second 5k6 resistor is added; the slider of the pot is connected to the slider of P1. And that's all!

Disc inputs

For two stereo inputs, you need four identical preamps. For clarity, only one of these is drawn in full in the circuit. As can be seen, this is a fairly standard two-transistor design.

The only point that may seem strange is the level control: a *linear* potentiometer! This is not a mistake, we can assure you. The point is that these potentiometers are 'loaded' by the common ('summing') connection to the output amplifier. This modifies the control characteristic, as described in Elektor 56, December 1979: 'Tailoring potentiometers'. Without going into all the complicated details, the effect can be summed up in a few words: logarithmic potentiometers become even more logarithmic, whereas linear potentiometers end up somewhere half-way between linear and logarithmic. In practice — and that's what counts! — the latter turns out to be an extremely good control characteristic for a mixing desk.

Tape input

In most cases, no gain is required for a tape input. The signal level is nearly always quite adequate already, and most recorders will quite happily drive the 25 k level potentiometer. However, to make assurance doubly sure, it was decided to add a very simple single-transistor buffer stage (T5). This has the added advantage that it becomes a simple matter (just changing a few resistor values) to tailor the input for other signal sources.

The output stage

The signal from the summing 'rail' (this is the junction of R10, R18, R24 etc.) is amplified by T6 and T7. The gain of this stage is determined by R28 and R29.

Parts list

Resistors:

R1, R101 = 68 k
 R2, R102, R43, R143, R243, R343, R443, R543 = 220 k
 R3, R103 = 27 Ω
 R4, R104, R40, R140 = 4k7
 R5, R105, R6, R106, R10, R110, R18, R118, R218, R318, R22, R122, R24, R124 = 18 k
 R7, R107, R8, R108, R21, R121, R26, R126 = 470 k
 R9, R109 = 10 k
 R11, R111, R211, R311 = 47 k
 R12, R112, R212, R312 = 330 Ω
 R13, R113, R213, R313, R14, R114, R214, R314 = 100 k
 R15, R115, R215, R315, R28, R128 = 3k9
 R16, R116, R216, R316 = 1k8
 R17, R117, R217, R317 = 470 Ω
 R19, R119 = 120 k
 R20, R120, R39, R139 = 56 k
 R23, R123 = 15 k
 R25, R125 = 820 k
 R27, R127, R33, R133, R35, R135, R36, R136 = 5k6
 R29, R129, R48 = 100 Ω
 R30, R130, R34, R134, R37, R137 = 2k2
 R31, R131, R32, R132 = 180 k
 R38, R138 = 560 k
 R41, R141 = 47 Ω
 R42, R142, R242, R342, R442, R542 = 5M6
 R44, R144, R244, R344, R444, R544 = 22 k
 R45, R145, R245, R345, R445, R545 = 1 k
 R46, R146, R246, R346, R446, R546 = 220 Ω
 R47 = 680 Ω
 P1, P2 = slide potentiometers mono 25 k lin. (58 mm)
 P3, P4, P5 = slide potentiometers stereo 25 k lin. (58 mm)
 P6, P7 = slide potentiometers stereo 50 k lin (58 mm)

Capacitors:

C1, C101, C3, C103, C5, C105 = 47 μ /16 V
 C2, C102 = 12 p
 C4, C104 = 39 n
 C6, C106, C206, C306, C14, C114, C21, C121, C22, C122, C30, C31, C32 = 10 μ /16 V
 C7, C107, C207, C307 = 22 n
 C8, C108, C208, C308, C11, C111 = 47 n
 C9, C109, C209, C309, C16, C116, C28 = 100 μ /16 V
 C10, C110, C210, C310, C24, C124, C17, C117 = 22 μ /16 V
 C12, C112 = 1 μ /16 V
 C13, C113 = 68 p
 C15, C115 = 220 n
 C18, C118 = 68 n
 C19, C119, C20, C120 = 4n7
 C23, C123 = 270 p
 C25, C125, C225, C325, C425, C525 = 100 n
 C26, C126, C226, C326, C426, C526 = 10 n
 C27 = 1000 μ /25 V
 C29 = 1000 μ /16 V

Semiconductors:

T1 ... T6, T101 ... T106, T203, T303, T204, T304, T8, T108, T9, T109, T209, T309, T409, T509 = BC 547B
 T7, T107, T10, T110, T210, T310, T410, T510 = 8C 557B
 D1 ... D4 = 1N4001
 D5, D6, D106, D206, D306, D406, D506 = LED (red)
 IC1 = 7812

Miscellaneous:

S1 = SPST switch
 L1, L101 = see text
 Tr1 = 12 V/400 mA transformer

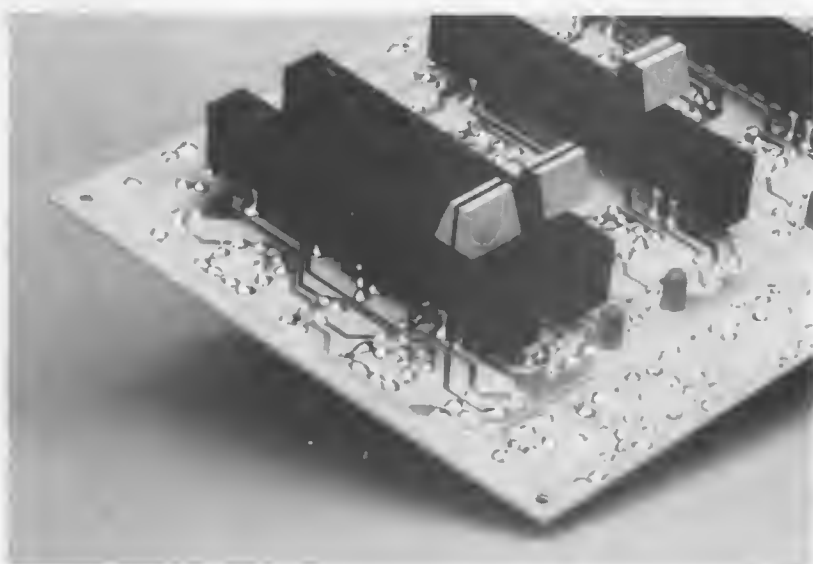

This photograph illustrates how the slider potentiometers, the switch and the LEDs are mounted on the copper side of the printed circuit board.

The 'monitor' output for tape recording is taken direct from the output of this stage, via R31 and R32, before the tone controls, which is the correct way of doing things.

The tone control itself is a variation on the well-known Baxandall principle. This is by no means as mystifying as some people would have you believe — on the contrary, the basic principle is really quite simple! The input signal comes in via C17, and a negative feedback signal is taken from the output through C22. Now, let's take a look at the upper of the two controls (P6). At very low frequencies C18 has no effect, so it can be ignored for the time being. This leaves us with a series connection of two fixed resistors and a potentiometer (equivalent to a 'potentiometer with limited travel'), connected between the input and the feedback signal. Depending on the position of the wiper, the signal at this point is mainly the input signal (wiper to the left) or mainly the feedback signal (wiper to the right). In the former case, the output level is high (high input level, low feedback) whereas in the latter the output level is low. However, this is only true at low frequencies, where C18 can be neglected. At higher frequencies, this capacitor forms a kind of short circuit across the potentiometer; the position of the wiper has no effect in this case. The input signal level and feedback level are approximately equal at higher frequencies, so that the overall gain is unity. So what have we got? A volume control at the low frequency end and unity gain outside this range. This is a reasonable description of a bass control! A similar explanation applies to the other control (P7), with the distinction that in this case only the high frequency end is passed to the control via C19 and C20.

From this fairly extensive description it should be clear how the tone controls can be modified according to personal taste. A higher turnover frequency for the bass control? Use a smaller value for C18! More 'effective' bass control? Reduce the values of R33 and R36 ('increase the travel of the potentiometer'). Obviously, modifications of this type must remain within reason: changing values by about a factor of three or four is the limit.

Signal indication

It was mentioned above that it would be useful to have one LED per channel, that indicates whether or not a signal is actually present at that input. No problem.

For the upper microphone input, for instance, the signal is taken off at A — before the level control. This signal is passed through an amplifier stage (T9, T10) to the LED (D6).

The output level from the mixer is also monitored in this way.

Power supply

The only point worthy of mention here is the choice of mains transformer. The total current consumption is higher than you might expect! The actual electronics only require about 20 mA, but the supply indicator LED (D5) adds another 20 mA — and with all LEDs full on the total consumption will be nearly 300 mA! For this reason, a 400 mA transformer is specified.

A few practical pointers

Construction shouldn't present any problems — certainly when using the board layout shown in figure 2.

There are also very few special components. As mentioned earlier, linear slider potentiometers are preferred. Logarithmic types can also be used, provided care is taken to get them 'the right way round'. Suitable sliders (58 mm travel) are available from several manufacturers.

Note that the sliders, as well as the switch and LEDs for that matter, are all mounted on the copper side of the board. To obtain sufficient mechanical support, six mounting holes are provided on the board. It is the intention that it is bolted firmly onto a rigid chassis at all six points — not just at two opposite corners!

To keep the total size down, miniature components are used. Not sub-miniature — just the normal kind. This is particularly noticeable for the electrolytics: slightly larger types will fit, but the really small ones make for a neater result.

A deliberate effort was made to make room for everything on the board: even the input and output sockets and the mains transformer. However, the printed circuit board mounting version of DIN sockets may not be so easy to come by, let alone the mains transformer. Obviously, in that case these components can be mounted 'off board'.

clear indication at low levels

level meter

Disco music is not only fun to listen to, it can also be very pleasing to the eye. This article describes a level meter that incorporates a compressor circuit so that the meter will give a definite indication even at low signal levels. In addition, the device can also be used for measuring the output of a power amplifier directly.

P. de Bra

Signal level meters are certainly not new to Elektor — in fact there are one or two different types mentioned elsewhere in this issue. In some instances however, such meters can be more of an inconvenience than an advantage as they do tend to give a somewhat precise indication. In practice this usually means that the meter needle is continually hovering around the end stop when low level input signals are monitored. If a LED level meter is used, only one or two LEDs out of a total of perhaps twenty will actually be lit. Before the meter will register any appreciable movement the volume of the music often has to be turned up to an ear-splitting, neighbour complaining level — all right for large halls, but not for the average living room!

1

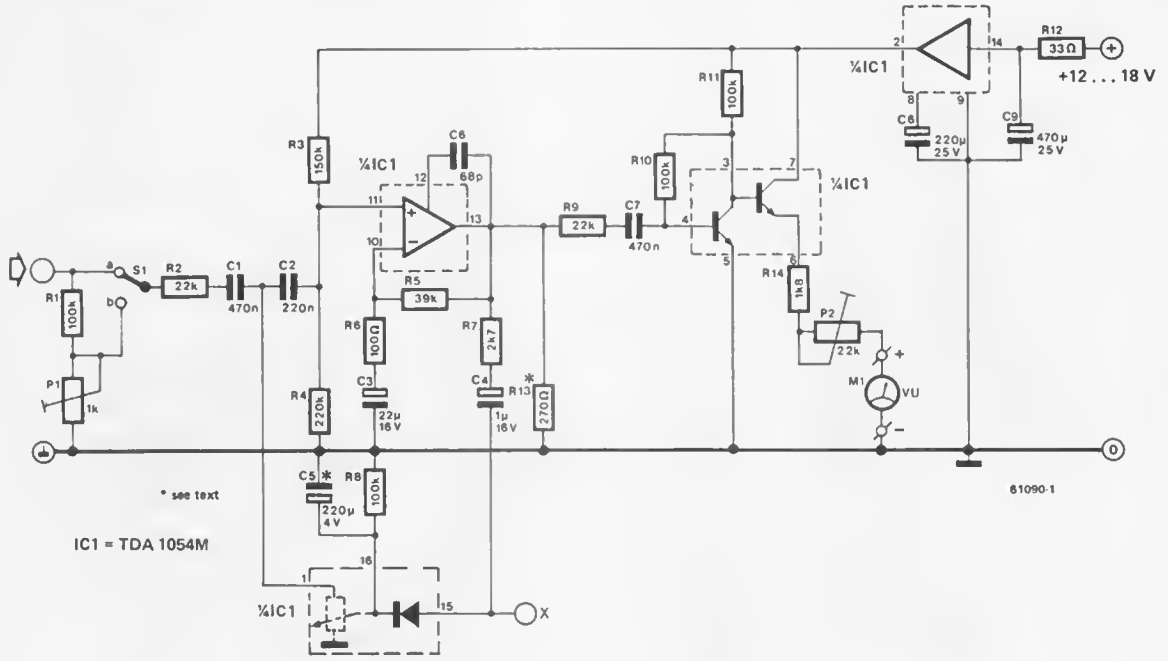

Figure 1. The circuit diagram of the level meter.

2

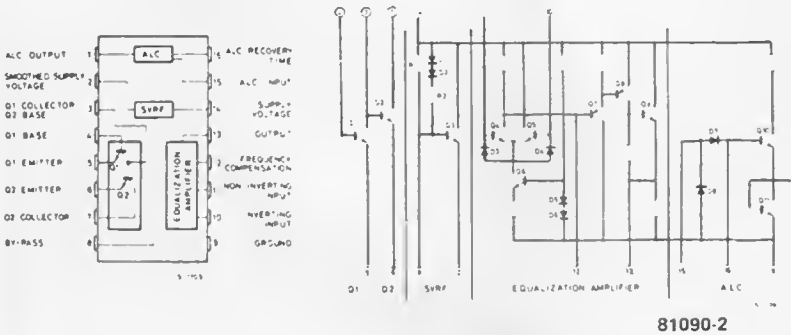

Figure 2. The TDA 1054M consists of several subsidiary circuits.

The obvious solution to this problem is to make better use of the lower volume range - or move to a larger house! An example of this was published in the form of an autoranger in the Summer Circuit 1979 issue of Elektor (circuit number 32). An alternative method is to use a compressor, as does the circuit presented here.

All that compression involves is to ensure that a large variation in the amplitude of the amplifier output signal leads to a small deflection on the meter. In other words, the meter needs to have a greater sensitivity for lower level signals. As a result, the meter will give a clear indication regardless of signal amplitude.

The circuit of the level meter (see figure 1) makes full use of the 'multi-function' TDA 1054M (SGS-Ates).

The internal structure of this device is given in figure 2. As can be seen from figure 1, the signal enters the system via switch S1. This switch is incorporated so that the meter can be used to measure the output amplitude of the amplifier in dBs. The automatic level control section of the TDA 1054M is used as a variable resistor connected between the junction of C1/C2 and ground. The 'value' of this resistor will depend on the amplitude of the signal at pin 13 of the IC, which in fact is the output of the compressor circuit. This signal is rectified before being fed to the variable resistor. In this manner the variable resistor effectively a 'controllable' potential divider with R2. The output of the compressor is also fed to a (two) transistor amplifier stage before being fed to the (VU) meter.

The remaining section of the IC is used to stabilise the supply voltage.

Now for some more technical considerations. The value of C5 affects the modulation period of the compressor. In practice, it may have virtually any value greater than 47 μ F. Resistor R13 has been included to maintain a low output impedance for the compressor. This becomes important when a stereo version is constructed, in which case the points marked 'X' on the circuit diagram have to be connected together to ensure that the compression ratio is the same for both channels. If a stereo version is not required, R13 can be omitted altogether, the current consumption will then drop from 28 mA to 8 mA.

To set up the unit, switch S1 should be in position 'a' and a sinewave signal with a frequency of 500 Hz and an amplitude of between 10 and 1000 mV applied to the input. Potentiometer P2 can then be adjusted to give an indication of around +1 to +3 dB on the meter. If necessary, P2 can be re-adjusted while experimenting with a music signal.

In addition to the above, the VU meter can also be used to measure the amplitude of the power amplifier output (switch S1 in position 'b'). For calibration purposes, a 500 Hz signal is again applied to the input, but this time its amplitude must correspond to \sqrt{PR} , where P represents the maximum power output of the amplifier and R the impedance of the loudspeaker. Potentiometer P2 should then be adjusted to give an indication of 0 dB on the meter.

Reliability

Two main factors determine the long term reliability of a particular project. Firstly, the way in which the circuit was designed and secondly, the manner in which it is put together. We know that the quality of components is also a factor which affects reliability, but modern components do not present that much of a problem if specified parameters are adhered to. Besides, the local retailer is not in the business to sell rubbish, since the amount of trade he does relies on his reputation.

ponent overlay that make the Elektor printed circuit boards so complete and simple to use.

However, a set of boards produced in the above manner still presents an attractive proposition. So far so good, but what about the quality of 'home made' boards? In many instances, this is an entirely different 'kettle of fish'. Because of either a lack of technical knowledge or expertise (or a mixture of both) the appearance of some 'home brewed' printed circuit boards is, to put it kindly, not entirely acceptable.

circuits and boards

What do your finished projects look like? Does the board in photo 1 look familiar? A Christmas tree of short circuits about to happen! Quite acceptable for prototypes (which the board in the photograph actually is), but not ideal for use in the home, or anywhere else for that matter. Nothing is better, as far as reliability and appearance are concerned, than a well constructed printed circuit board. There is also the safety aspect. A 'lash up' could become very expensive if it induced the transformer to take up smoking!

The design of an Elektor circuit has reliability built in, therefore the hard work for that aspect has already been taken care of. All that remains now is the actual construction of the project and this can either make it or break it. The quality of construction depends almost entirely on you, the reader. We say almost entirely because Elektor endeavor to go a long way in aiding the amateur to produce the best possible finished project by supplying the best possible printed circuit boards through the Elektor Print Service (EPS).

In spite of this, many readers still prefer to manufacture their own printed circuit boards for a variety of reasons. For instance, producing a number of boards at one time from one sheet is very reasonable in terms of cost. Admittedly, there is still a fair amount of work to be done. All the holes will have to be drilled and the boards will not have the solder resist mask or com-

Furthermore, it doesn't stop there. A number of boards supplied in answer to advertisements often arrive in a similar state of inferiority, which probably gives rise to the opinion that this is the normal standard expected from a home made board.

Professional results

So what degree of quality can be achieved by producing a printed circuit board at home? This does, of course, depend on which of the numerous methods are employed. Various special pens and tapes are available on the market for marking out the track pattern to be etched and many readers manage to obtain very reasonable results using them. However, the generally accepted method of achieving first class results every time is the photographic system whereby a transfer (or similar) is used for the track pattern. This is then

1

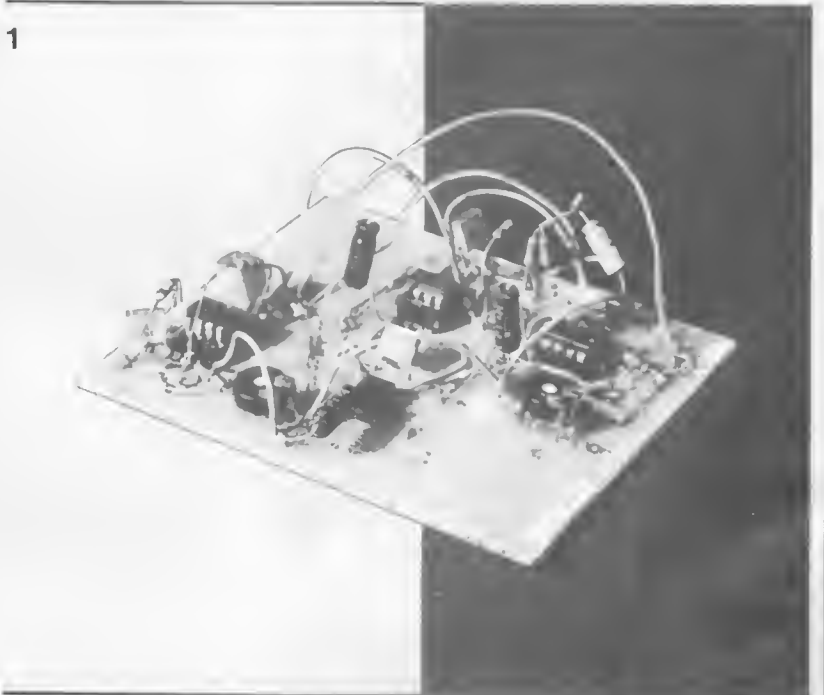

2

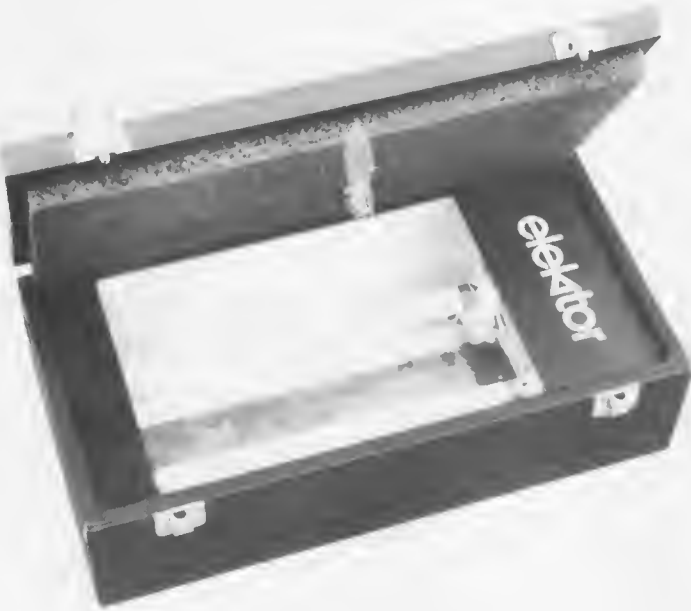

used as the 'master' for reproducing the pattern on 'pre-sensitised' board. The board, together with the transfer, is subjected to an ultra-violet (UV) light source for a period of around 3...6 minutes. The board is then etched in a ferric chloride solution in the normal manner, but the results will be as good as the transfer. This method also ensures that the transfer can be used any number of times, provided it is treated with care.

Normally speaking, this method of producing printed circuit boards is not such an easy task for the average enthusiast, mainly because the UV light source is not so readily obtainable at a reasonable price. Up to now, that is...

UV light box

We have received many letters from readers requesting an article on the subject of an ultra-violet light box. Unfortunately this type of project is fraught with difficulties that the reader may not be in the position to overcome. However, in view of the demand, Elektor have decided to make the project available from another source, namely Fotomechanix Ltd. (Unit 110, Middlemore Industrial Estate, Middlemore Road, Smethwick, Warley, West Midlands, B66 2EP). This company are producing the excellent UV light box shown in the accompanying photographs. It can be supplied by Fotomechanix in the form of a complete kit at the low price of £24.50 to Elektor readers. If required, a larger version is available either direct from the manufacturers or from Marshall's.

The UV light box kit includes all the necessary parts for the oscillator (including the printed circuit board) together with the two 6 watt ultra-violet 'tubes' mounted in the base of the box as shown in photo 4. Should the need arise, the tubes can be replaced easily by the simple process of removing the two screws holding the end section in place and sliding out the glass mounting plate.

3



The method of construction can be clearly seen from photo 3. Many readers may decide to incorporate a variable timer into the system. Suitable circuits have been published in Elektor on numerous occasions. It must be pointed out that UV light can damage the eyes, therefore it is imperative that the lid be kept shut all the time that the unit is switched 'on'. Alternatively, a micro switch could be fitted to the lid itself so that the unit can not be operated until the lid is closed.

Transfer sheets

As mentioned earlier in the article, a really professional finish is virtually guaranteed when a good quality 'mask' is used for reproducing the track pattern. The two new transfer sheets now available from Elektor are intended specifically for this particular purpose. They can be used in one of two ways. Since they are a dry transfer, they can of course be rubbed down directly onto the copper side of the board. The etching can then be carried out in the normal manner. The transfer is then removed during the 'cleaning up' operation that follows. The major disadvantage of this method is that the transfer itself is then lost. This presents a problem if more than one copy of a particular board is required. The solution to this is the UV box. In this instance the transfer is used as photographic 'negative' in conjunction with the photosensitive copper laminate board. This process does not damage the transfer in any way (provided it is handled with due care and attention), thus allowing it to be used as often as desired.

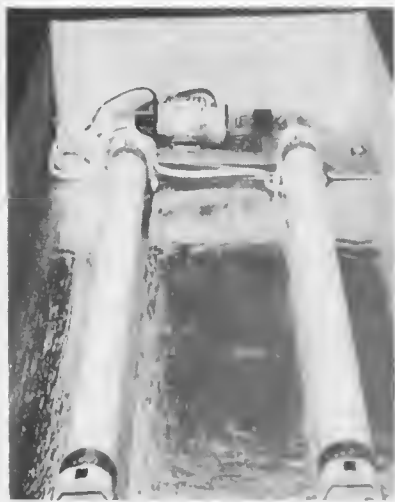
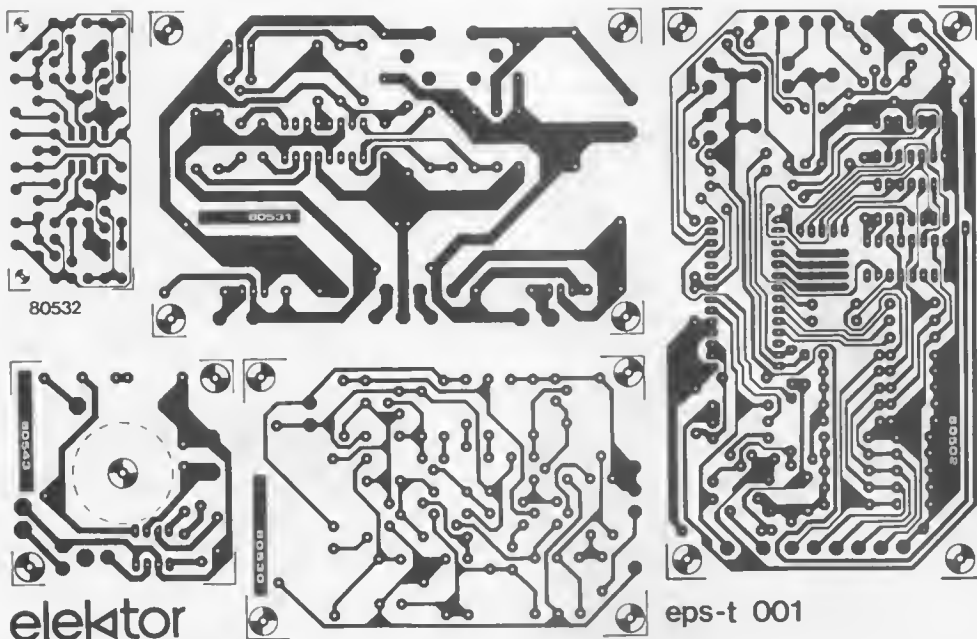

The two dry transfer sheets are illustrated here and consist of printed circuit board layouts for the following projects:

- eps-t 001
- 80502 musical box
- 80530 ultra low power amplifier
- 80531 μ P switching power supply
- 80532 stereo dynamic preamplifier
- 80543 super tiny amplifier (STAMP)

This sheet was presented in the July/ August 1980 double issue of Elektor.

- eps-t 002
- 81041 drinks round indicator
- 81043 canometer (main board)
- 81043 canometer (display board)
- 81044 multican
- 81047 bath thermometer
- 81049 NiCad piggy bank
- 81051 xylophone

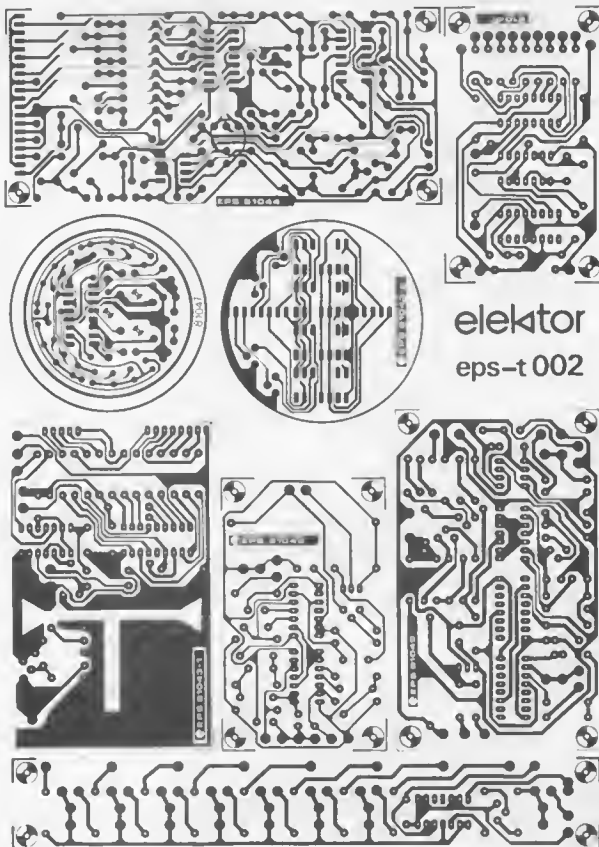

All these projects can be found in the December 1980 issue of Elektor. These two transfers can be obtained

from the Canterbury office of Elektor (see latest EPS list for price and ordering details).

Many designs for digital (LED) VU meters have found their way into the pages of Elektor in the past. This type of meter is normally used to monitor the amplitude of audio signals by means of a row LEDs. The level indication is provided either by a single LED being lit, or by a "bar" of LEDs — the more sophisticated versions allow a choice between the two.

The VU meter presented here can be considered as having two completely separate sections, namely a low voltage section and a high voltage (240 V) section. The circuit diagram of the low voltage section is given in figure 1. As can be seen, the input signal is fed to the sensitivity control potentiometer, P1, via resistor R1. When this potentiometer is adjusted to give a voltage of approximately $1 V_{eff}$ on its wiper the display will give a maximum indication of +6 dB. A wiper voltage of around $0.5 V_{eff}$ will then give a reading of 0 dB. Input overload protection is provided by the two zener diodes D1 and D2. As long as the input voltage remains below

completely symmetrical output signal, resistors R6, R7 and R8 should have a tolerance of 1%. Opamps A3 and A4 are connected as a comparator and an integrator respectively. When the signal level at the inverting input of A3 exceeds that of the output A4, the output voltage of the comparator will swing to $-12 V$. Part of this voltage is then fed to the inverting input of the integrator via the potential divider R11/P2/R12 and resistor R13. The output voltage of the integrator will then increase until it reaches the same level as the signal at the input of the comparator. If, however, the signal level at the inverting input of A3 is less than the output sig-

the big VU meter...

... with a thousand Watt readout

Naturally, these VU meters are far too small to use for special lighting effects in a discotheque. The version described here, however, can be constructed large enough to overcome even this problem!

approximately $7.5 V_{pp}$, the zener diodes will have no effect on the circuit, but as soon as the input voltage rises above that level they will start to conduct. If the VU-meter is to be connected directly to the output of a power amplifier, the value of R1 will have to be altered so that a voltage of $1 V_{eff}$ can easily be obtained at the wiper of P1 (see table 1). Opamps A1 and A2, together with associated components, form a precision full wave rectifier. In order to achieve a

nal of the integrator, the output of the comparator will swing to $+12 V$. This causes the output voltage of the comparator to decrease until it reaches the same level as the input voltage to A3. The time required for the integrator output level to equal that of the comparator input is determined by C2, R13 and the setting of potentiometer P2. This time period can be adjusted linearly with the aid of P2 to any value between 50 ms and 1.5 s. The output of A4 is also fed to the

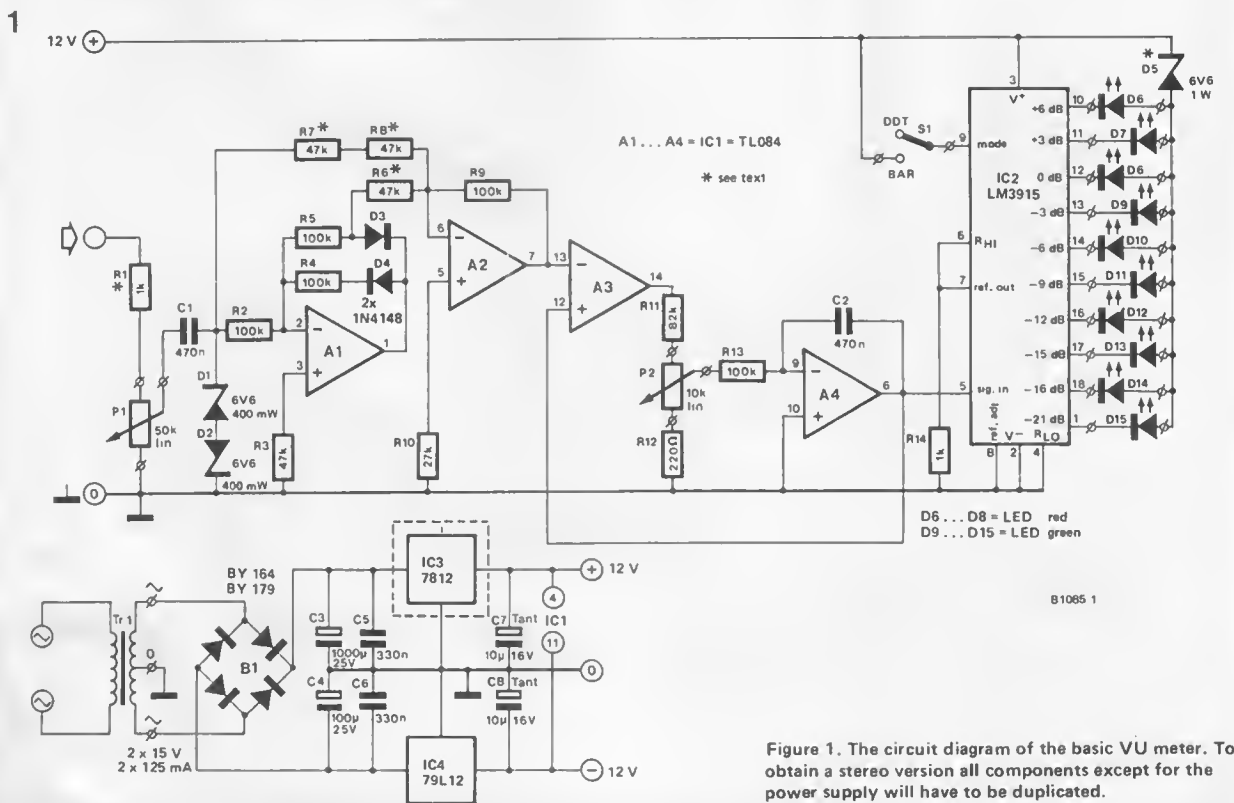

Figure 1. The circuit diagram of the basic VU meter. To obtain a stereo version all components except for the power supply will have to be duplicated.

signal input (pin 5) of the LM 3915, IC2. This IC contains, amongst other things, a precision potential divider and ten comparators. This means that an equivalent number of LEDs can be connected to the outputs of the comparators to give an indication of the amplitude of the input signal. A linear variation in input voltage is converted into a logarithmic (LED) scale (-21 dB . . . +6 dB, in 3 dB steps). A voltage level of +1.25 V is required at the signal input of the IC to give the maximum +6 dB output indication. The current passing through each LED is determined by the value of R14, and will be approximately ten times the current drawn by this resistor - in this case about 12 mA. When pin 9 is disconnected, that is to say when switch S1 is in the "dot" position, only one LED will light at a time. When the switch is in the "bar" position, a number of LEDs will light in a row, the actual amount corresponding to the amplitude of the input signal.

2

Table 1

amplifier power rating	value of R1
< 1 W	1 kΩ
≈ 1 W	50 kΩ
≈ 10 W	270 kΩ
≈ 50 W	560 kΩ
≈ 100 W	820 kΩ

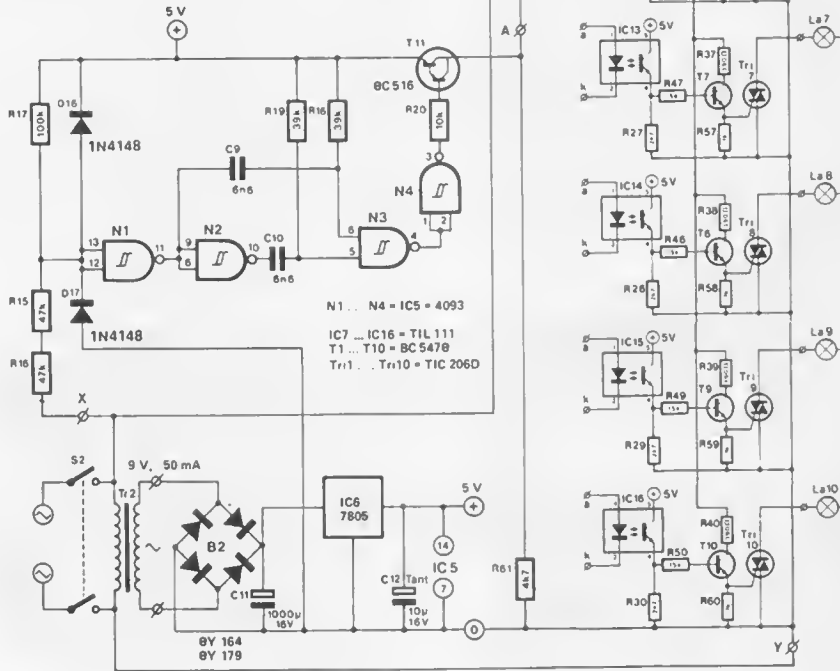

81085 2

Figure 2. The circuit diagram of the 240 volt extension. This circuit can be added to the one shown in figure 1 to produce a somewhat "vivid" display.

So far we have only mentioned an ordinary "common or garden" LED VU meter. To obtain a "larger than life" 240 V display the circuit shown in figure 2 needs to be added. Instead of the LEDs D6 . . . D15 of figure 1, the LEDs incorporated in the opto-couplers IC7 . . . IC16 in figure 2 are now connected to the outputs of IC2. The two boards are interconnected by a score of wire links. Make sure that the zero volt line of figure 2 is connected to the neutral side of the mains supply and *NOT* to the zero volt line of figure 1.

A zero crossing detector is formed by the circuit around N1 . . . N4 and T21. The input of the zero crossing detector is connected to the same side of the mains supply as the lamps — *the live side!* This means that resistors R15 and R16 must be at least ¼ Watt types. It also means that extreme care must be taken when fault finding! Diodes D16 and D17 have been included to protect the input of N1 against excessive input voltages. Under normal conditions a squarewave signal of between -0.7 V and +5.7 V will be present at this input. Therefore, the squarewave output of N1 will change state at every zero crossing. Differentiators C9/R18 and C10/R19 generate a negative going pulse at each positive and negative transition of this squarewave respectively. These two pulses are then ANDed together by N3 and N4 so that a negative going pulse of about 250 µs duration is present at the

Parts list for figures 1 and 3

Resistors:

- R1 = 1 k*
- R2,R4,R5,R9,R13 = 100 k
- R3 = 47 k
- R6 . . . R8 = 47 k*
- R10 = 27 k
- R11 = B2 k
- R12 = 220 Ω
- R14 = 1 k
- P1 = 50 k lin
- P2 = 10 k lin

Capacitors:

- C1,C2 = 470 n
- C3 = 1000 µ/25 V
- C4 = 100 µ/25 V
- C5,C6 = 330 n
- C7,C8 = 10 µ/16 V tantalum

Semiconductors:

- IC1 = TL084
- IC2 = LM3915
- IC3 = 7812
- IC4 = 79L12
- D1,D2 = 6V8/400 mW zener
- D3,D4 = 1N4148
- D5 = 6V8/1 W zener*
- D6 . . . D8 = red LED
- D9 . . . D15 = green LED

Miscellaneous:

- B1 = 100 V/0.5 A bridge rectifier (BY 164, BY 179)*
- S1 = SPST*
- Tr1 = 2 x 15 V, 125 mA transformer*

* see text

Parts list for figures 2 and 4

Resistors:

- R15,R16 = 47 k ¼ W*
- R17 = 100 k
- R18,R19 = 39 k
- R20 = 10 k
- R21 . . . R30 = 2k7
- R31 . . . R40 = 390 Ω
- R41 . . . R50 = 15 k
- R51 . . . R60 = 1 k
- R61 = 4k7

Capacitors:

- C9,C10 = 6n8
- C11 = 1000 µ/16 V
- C12 = 10µ/16 V tantalum

Semiconductors:

- T1 . . . T10 = BC547B
- Tri11 . . . Tri20 = TIC206D*
- T21 = BC516
- IC5 = 4093
- IC = 7805
- IC7 . . . IC16 = TIL 111
- D16,D17 = 1N4148

Miscellaneous:

- B2 = 100 V/0.5 A bridge rectifier (BY 164, BY 179)*
- S2 = DPST (mains switch)
- Tr2 = 9 V, 50 mA transformer*
- La1 . . . La10 = 240 V lamp (maximum 100 W)

* see text

3

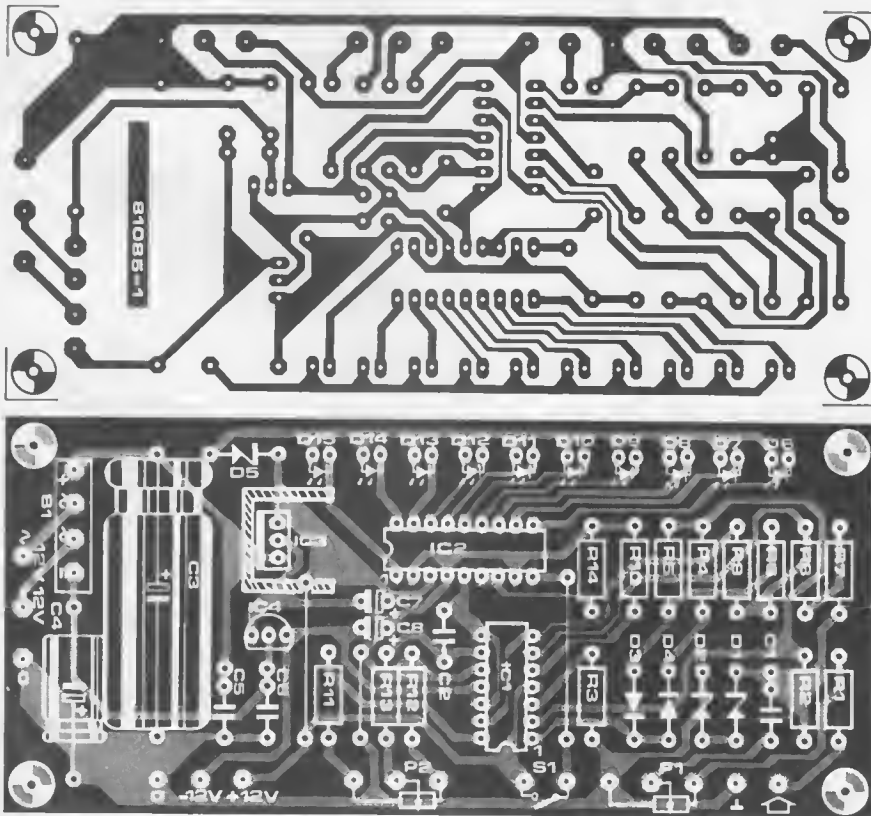

Figure 3. The printed circuit board and component overlay for the circuit of figure 1.

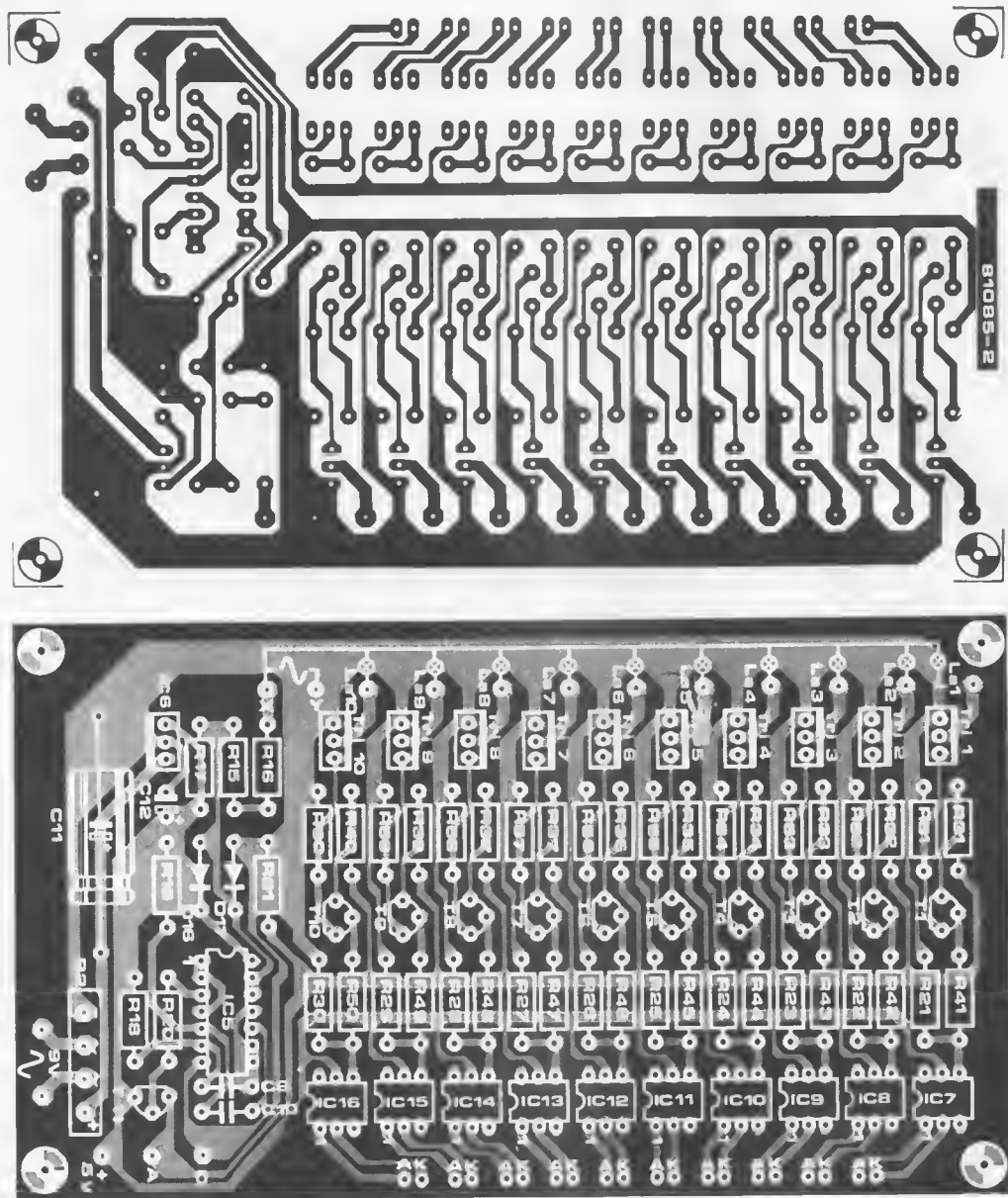

Figure 4. The printed circuit board and component overlay for the 240 volt extension circuit of figure 2.

output of N4 at every zero crossing of the mains. As a result, the light bulbs can only be turned on at the moment the main supply voltage "crosses zero", provided of course the LED in the corresponding optocoupler is lit. Once the triac is triggered, it will continue to conduct for at least one half cycle of the mains voltage. If at the next zero crossing the LED in the optocoupler is still lit the triac will continue for a further half cycle. If, however, the LED goes out, the triac will turn off and the associated lamp will also go out. The recommended type of triac is the TIC206D, but any similar type will suffice provided it has a trigger threshold of about 5 mA and a maximum

reverse voltage of 400 V or greater. Individual printed circuits boards have been designed for the circuits of figures 1 and 2. This enables the VU meter to be used with or without the 240 volt section as required. The latter board can also be used as a separate universal interface (mains isolated) for up to ten channels. The power supplies have been designed to deliver enough current for a stereo version of the VU meter. In this instance, however, the current rating of the transformers will have to be increased. Components B1, C3 . . . C6, IC3 and IC4 can be omitted from the second low voltage board and the power supply connections (+12 V, 0 V and

-12 V) can be joined to the first board. Similarly, B2, C11, IC6 and the complete zero crossing detector are not required on the second high voltage board. The corresponding points A, X, Y, 0 and +5 of the two high voltage boards are then interconnected. In addition, stereo potentiometers and a double pole switch will now have to be used. If required, the VU meter can be constructed to give a LED display and a 240 V lamp display simultaneously. In this instance LEDs D6 . . . D15 are connected in series with those inside the optocouplers. The value of the zener diode D5 will then have to be altered to 4V7/1W.



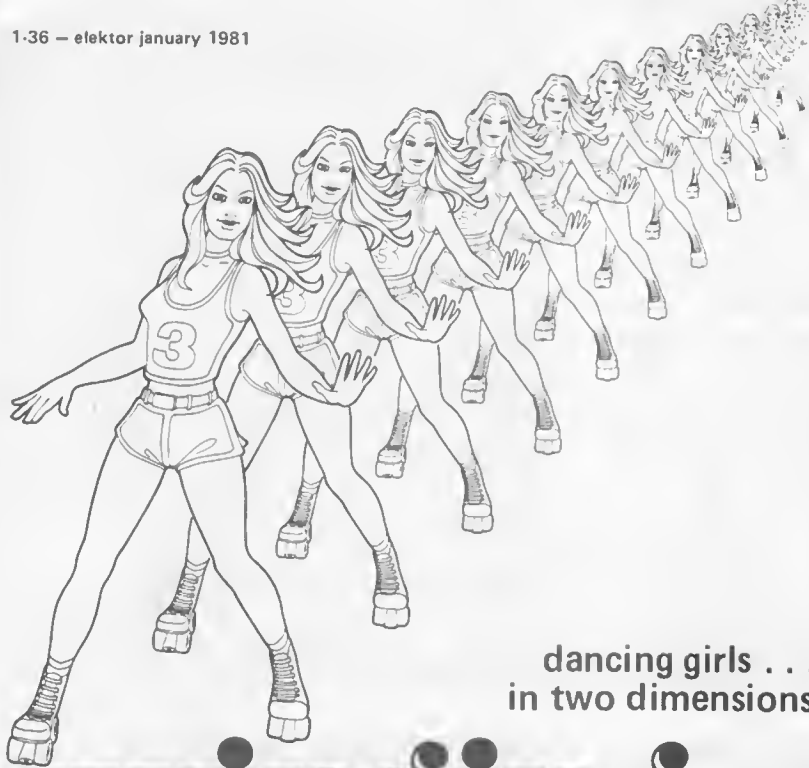

dancing girls . . .
in two dimensions

swinging poster

What do you need in a 'disco'? A dance floor, lighting effects and music of a sort. A novel effect is described here: a 'swinging poster' — one that moves while staying in place. Quite a feat! Sorry, feat. The trick is to use two different-coloured lamps that flash alternately, in a random sequence. When the red lamp is on, you see the red illustration and not the green, and vice versa. The result is that the girl appears to 'dance' in a flashing background.

The whole atmosphere of a disco depends on the sum total of sound, lights, movement and dancing. Everything is moving: people, spotlights, and often all kinds of mechanical devices. Taken together, it all works as an invitation to 'get with it' and 'get moving'. You're certainly not supposed to sit at the bar nursing your beer all evening.

The dancing girls described here fit perfectly into the 'scene'. They can form an attractive addition to any disco — both the big-city and the at-home type. There is nothing spectacular about the basic idea. The poster itself shows two dancing girls, one in red and the other in green, surrounded by a multitude of green and red stars. Shine a red lamp on it and you see the red girl; a green lamp brings out her green twin. For obvious reasons, this system is only really effective in relatively dark surroundings. This shouldn't be a problem, however.

If the red and green lamps are switched on alternately, the girl appears to dance to and fro. This can get monotonous if

the lamps are switched at regular intervals, and for this reason a more random drive is used here.

The circuit

As can be seen from the block diagram (figure 1), the circuit consists of three parts: two electronic switches (one for each lamp) and the 'random' control circuit to drive the switches. The 'speed' of this random controller can be varied over a wide range, to obtain the desired effect.

The actual result is a fixed switching sequence that repeats every hour at the highest control frequency — or every 18 hours at the lowest. It is highly unlikely that anyone will notice when it starts to repeat itself!

Switching at the zero-crossing

The lamps are switched by means of

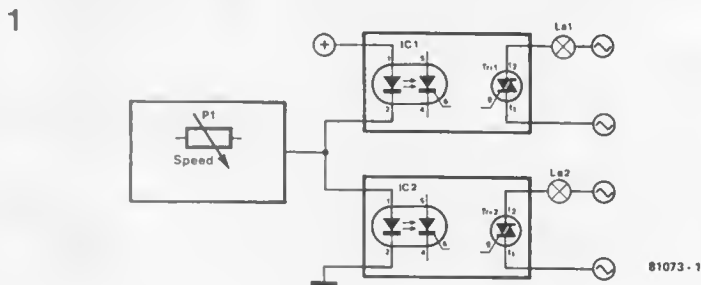
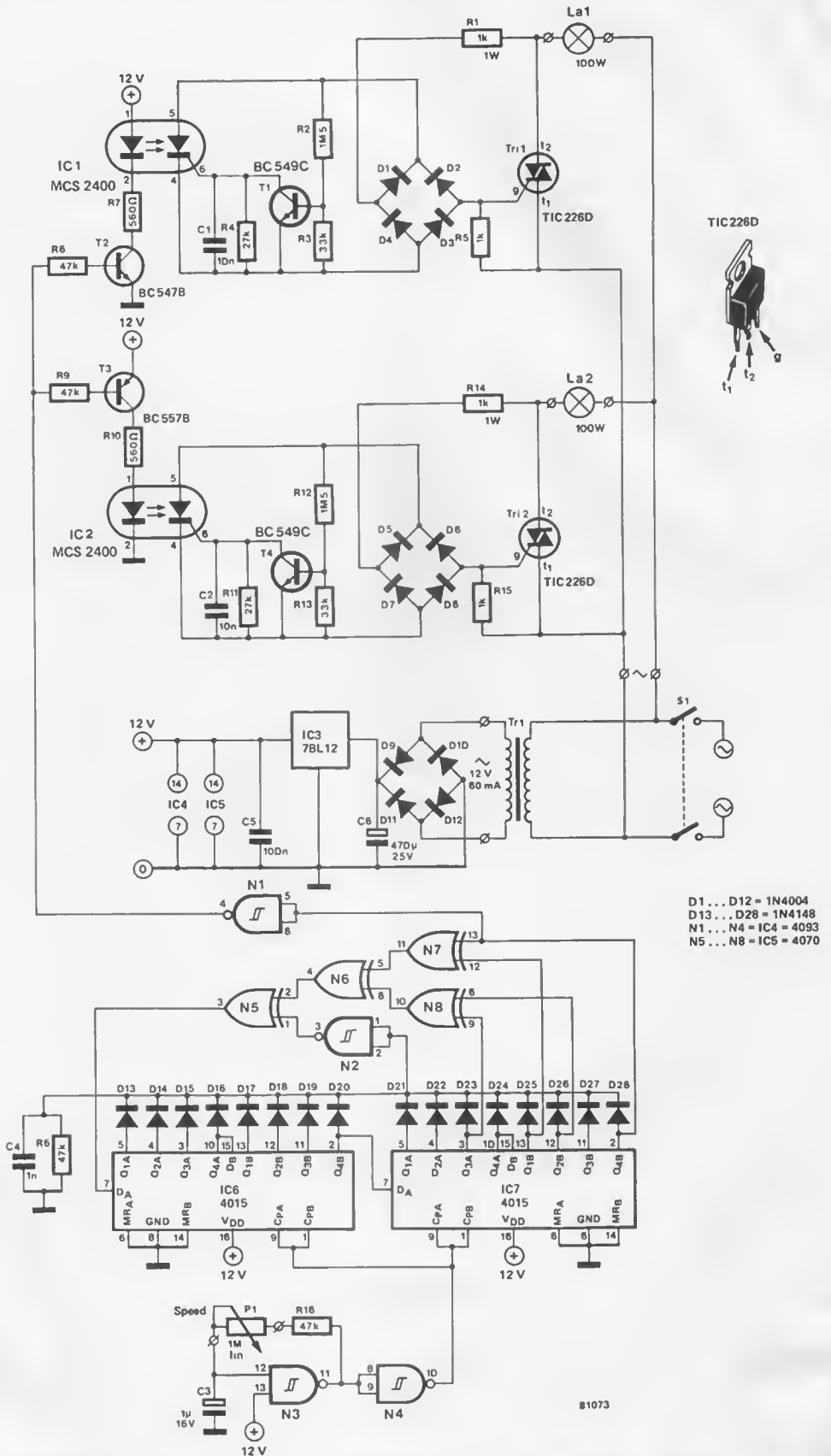

Figure 1. Block diagram of the lamp drive circuit for the 'dancing girls'. Two zero-crossing switches are controlled by a random sequence generator.



D1 ... D12 = 1N4004
 D13 ... D28 = 1N4148
 N1 ... N4 = IC4 = 4093
 N5 ... N8 = IC5 = 4070

81073

Figure 2. The complete circuit. The upper section consists of two zero-crossing switches that drive the lamps; the random sequence generator is shown below.

electronic zero-crossing detectors. Switching at the zero-crossing of the mains waveform has the advantage that it produces much less interference.

This part of the circuit is shown in figure 2. It consists of two identical sections, one for each lamp. The easiest way to understand this type of circuit is to 'run through it backwards' — in other words, start at the end and work back to the beginning.

For the lamp to light, the triac (Tri1) must be turned on; and to turn on the triac, current must flow to its gate. This current is derived from the full mains voltage, via R1. However, current can't flow 'straight across' the bridge rectifier, fortunately (if it could, you'd need a new bridge); so it must flow from R1 through D1, the photo-thyristor in IC1 and D3 to the gate of the triac.

For this to work, the thyristor must be turned on. This is where synchronisation to the mains zero-crossings occurs. For the thyristor to turn on (triggering the triac), two conditions must be met: current must flow through the LED in IC1, so T2 must be turned on; and the gate of the thyristor must not be shorted to its cathode, so T1 should be turned off. This means that, if we assume that T2 is turned on at a certain point, nothing will happen as long as T1 remains conducting. The base drive for T1 is derived, via R2 and R3, from the rectified mains voltage across the bridge rectifier. The resistor values are chosen so that this transistor is turned on for almost the full cycle of the mains waveform; it only turns off briefly in the immediate vicinity of the zero crossings. At that point — bingo! — the triac fires.

The triac will now remain 'on' as long as current is flowing through the LED in the optocoupler (IC1). When T2 is turned off, the triac will also turn off as soon as the next zero-crossing occurs.

The optocoupler also takes care of the electrical safety aspect. All parts of the circuit 'to the left of the LEDs' are safe; the remainder — the lamp control circuits proper — are connected to the mains.

Random flashes

The basic idea behind a 'digital, pseudo-random noise generator' has been discussed before (Elektors 21 January 1977 and 33 January 1978). By 'digital noise', we mean a random sequence of zeroes and ones, as shown in figure 3. The 'pseudo-random' aspect refers to the fact that there is actually a fixed cycle that repeats at regular intervals; however, the total cycle time can be so long (several hours, or even days) that the result seems to be truly random.

This type of output signal can be obtained from a few shift registers, with EXOR feedback added. Sounds complicated? Don't worry, it is. Those readers who are still interested in the theory can read on; the others may skip this section and proceed at 'construction'...

3



81073 · 3

Figure 3. This shows a brief portion of the output from the random sequence generator.

4a

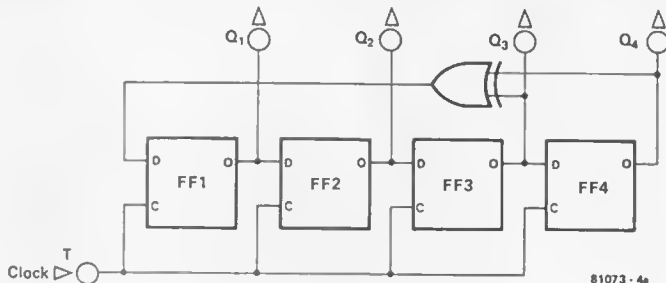

81073 · 4a

b

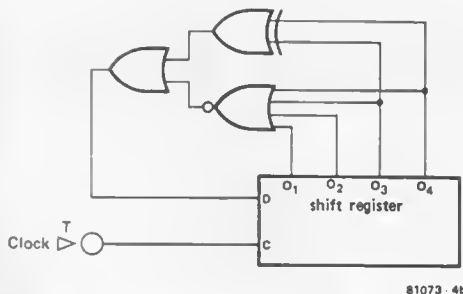

81073 · 4b

Figure 4. A basic four-bit random generator is shown in figure 4a; it consists of a 4-bit shift register and an EXOR gate. To avoid the rather boring, perpetual all-zero output, the four outputs can be taken back to the input via a NOR gate, as shown in figure 4b.

The basic idea can be explained with reference to figure 4. This shows the 'inside view' of a four-bit shift register (four flip-flops), with a single EXOR gate that feeds the Q3 and Q4 signals back to the input. The clock frequency determines the speed at which ones or zeroes shift down the chain.

Assuming that, initially, only output Q1 is at logic one, what happens is as follows. At the first clock pulse, all data shifts one place right; the output from the EXOR gate (still logic 0) shifts in at the left. The score so far: Q1 = 0, Q2 = 1, Q3 = 0 and Q4 = 0. This leaves the EXOR output at logic 0, so after the next clock pulse we get: 0 · 0 · 1 · 0. Q3 is now at logic 1, taking the EXOR output high; at the next clock pulse, this is shifted in at the left: 1 · 0 · 0 · 1. Continuing in this way — and bearing in mind that if both Q3 and Q4 are at logic 1, the EXOR output becomes logic 0! — we find a sequence of zeroes and ones that starts to repeat after fifteen steps. The 'missing' combination of zeroes and ones is 0 · 0 · 0 · 0. This combination is not only missing: it's forbidden! Since the output of the EXOR would be zero

in this case, it would never change. This problem can be avoided, as shown in figure 4b: all four outputs are connected to the input via a NOR gate. This means that when all four outputs are '0', a '1' appears at the input to the shift register.

Getting back now to figure 2, the actual 'random noise' generator is shown in the lower half of the circuit. To obtain a longer total cycle, a 16-bit shift register is used (IC6 and IC7). In this case, a rather more complicated type of EXOR feedback is required, from outputs 11, 13, 14 and 16. This is done by gates N6...N8. The 'all-zero' suppression is obtained by means of a whole series of diodes (D13 to D28) that OR all sixteen outputs; the result is inverted by N2 to obtain the desired NOR function. The total sequence obtained in this way consists of 65535 different zero-one combinations.

It doesn't make any difference which output of the shift register is used to drive the lamps, since all outputs will provide the same sequence of zeroes and ones if you wait long enough. In this circuit the extreme right-hand output is

5

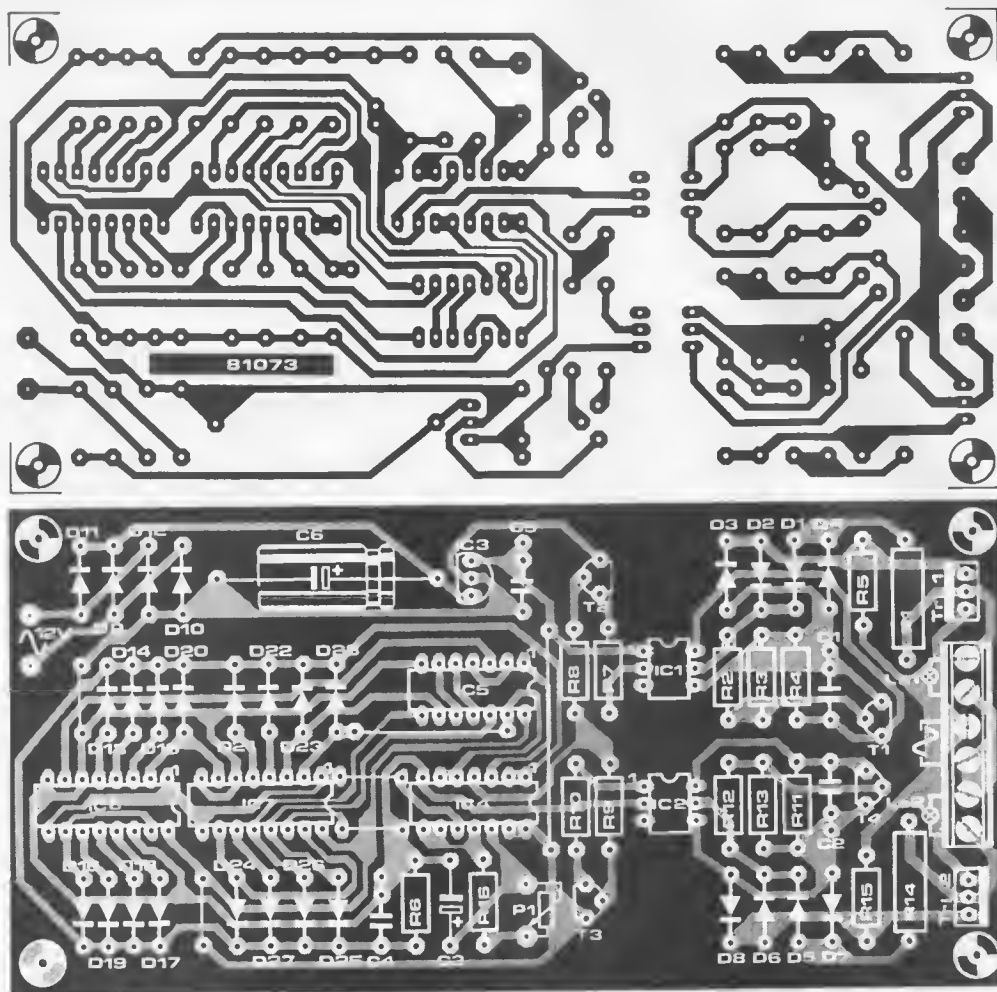

Figure 5. The printed circuit board and component layout for the circuit. Bear in mind that almost half of the circuit is connected to the full mains voltage! There is no need to cool the triacs if only 100 W lamps are to be switched.

Parts list

Resistors:

- R1,R14 = 1 k/1 W
- R2,R12 = 1M5
- R3,R13 = 33 k
- R4,R11 = 27 k
- R5,R15 = 1 k
- R6,R8,R9,R16 = 47 k
- R7,R10 = 560 Ω
- P1 = 1 M linear potentiometer

Capacitors:

- C1,C2 = 10 n
- C3 = 1 μ/16 V
- C4 = 1 n
- C5 = 100 n
- C6 = 470 μ/25 V

Semiconductors:

- D1 ... D12 = 1N4004
- D13 ... D28 = 1N4148
- T1,T4 = BC 549 or equ.
- T2 = BC 547B or equ.
- T3 = BC 557B or equ.
- Tri1, Tri2 = TIC 226D
- IC1, IC2 = MCS 2400 (Monsanto)
- IC3 = 78L12
- IC4 = 4093
- IC5 = 4070
- IC6, IC7 = 4015

Miscellaneous:

- S1 = mains switch
- Tr = 12 V/50 mA mains transformer
- La1 = 100 W red 'Flood' lamp
- La2 = 100 W green 'Flood' lamp
- swinging poster (EPS 81073-P)

used, driving T2 and T3 via N1. N3 and N4 are used as the clock oscillator. The frequency can be varied (with P1) between 1 Hz and 20 Hz.

Construction

A suitable printed circuit board design is given in figure 5. Construction is quite straightforward. The triacs only need to switch 100 W lamps, so there is no real need for cooling fins. It is highly advisable to mount the whole circuit in a plastic case. A large part of the circuit is connected to the full mains voltage! The only external controls are the potentiometer and the mains switch.

Now comes the proof of the pudding . . . Making the poster come to life! We have found that red and green 'Flood' lamps work quite well. They should be mounted so that they just light up the complete picture. As mentioned earlier, the effect is best in fairly dark surroundings. It may be worthwhile to experiment with a few different types of lamp - the more accurately the colours correspond with those on the picture, the better the final result!



BASIC calendar

A. Langenberg

Readers who own an Elektor BASIC computer and who did not receive a calendar for Christmas have no need to worry about whether the shops will have any left after the festivities. This program can be used to compile a calendar for any year between 1582 and 2100. As the Elektor BASIC computer runs on a form of Tiny BASIC (NIBL = National Industrial BASIC Language) it should be fairly easy to modify the program to run on other machines if required.

Once the program has been entered and started (RUN) the processor calculates the ASCII values for each of the days from 1 to 31. These values, along with relevant spaces, are stored in table form from the first available spare memory location (TOP). All this is carried out from lines 800 to 910. The processor then returns to the main section of the program (lines 10 to 360) which consists of two nested FOR . . . NEXT loops.

Following the entry of a valid year (lines 10 to 15), the first Sunday and the last day of each month is determined with the aid of the 'calculate day' subroutine (lines 380 to 540). During subsequent subroutines the names of the days and months are determined and are tabulated along with the actual date. This program should come in very useful for keeping track of personal software data.

```
>LIST
1 REM *** CALENDAR PROGRAM ***
5 GOTO 800
10 K=-2:L=-1:M=0:PR "YEAR";:INPUT C
12 IF C<1582 PR"I CAN'T REMEMBER AS FAR AS",C:GOTO 10
15 IF C>2100 PR C,"IS TOO FAR INTO THE FUTURE!":GOTO 10
20 PR"                                CALENDAR                                ",C:PR""
30 FOR I=1 TO 4
40 K=K+3:L=L+3:M=M+3
50 GOSUB 740
60 A=1:B=K
70 GOSUB 390
80 IF Y=1 O=A :GOTO 100
90 A=A+1:GOTO 70
100 A=30:D=32
110 GOSUB 390
120 IF D=A E=D:GOTO 140
130 A=A+1:GOTO 110
140 A=1:B=L
150 GOSUB 390
160 IF Y=1 P=A:GOTO 180
170 A=A+1:GOTO 150
180 A=29:D=32
190 GOSUB 390
200 IF D=A F=D:GOTO 220
210 A=A+1:GOTO 190
220 A=1:B=M
230 GOSUB 390
240 IF Y=1 Q=A :GOTO 260
250 A=A+1:GOTO 230
260 A=30:D=32
270 GOSUB 390
280 IF D=A G=D:GOTO 300
290 A=A+1:GOTO 270
300 FOR J=0 TO 6
310 GOSUB 660
320 R=O:S=8-O:D=E:GOSUB 560
330 O=O+1:R=P:S=8-P:D=F:GOSUB 560
340 P=P+1:R=Q:S=8-Q:D=G:GOSUB 560
350 Q=Q+1:PR"":NEXT J
355 PR""
360 NEXT I
370 END
380 REM SUBR. CALCULATE DAY
390 IF B=2 IF A>29 GOTO 500
400 IF B=2 IF A=29 IF MOD(C,4)>0 GOTO 500
410 IF B=2 IF A=29 IF C=1700 GOTO 500
420 IF B=2 IF A=29 IF C=1800 GOTO 500
430 IF B=2 IF A=29 IF C=1900 GOTO 500
440 IF A=31 IF B=4 GOTO 500
450 IF A=31 IF B=6 GOTO 500
460 IF A=31 IF B=9 GOTO 500
470 IF A=31 IF B=11 GOTO 500
480 IF A>0 IF A<32 IF B>0 IF B<13 GOTO 510
500 D=A:RETURN
510 IF B>2 GOTO 530
520 X=C+A+31*(B-1)+(C-1)/4-3*((C-1)/100+1)/4:GOTO 540
530 X=C+A+31*(B-1)-(4*B+23)/10+C/4-3*(C/100+1)/4
540 Y=MOD(X,7):RETURN
560 REM SUBR. PRINT TABLE
570 Z=1:IF R-J=1 GOTO 610
580 IF S>0 H=0:GOTO 600
590 H=S*4+4
600 PR$(TOP+H);:Z=Z+1
610 H=R*4
620 PR$(TOP+H);:Z=Z+1:R=R+7
630 IF R<D GOTO 610
640 IF Z>6 PR$(TOP+128);:RETURN
650 H=0:GOTO 620
660 REM SUBR. PRINT DAY OF THE WEEK.
670 IF J=0 PR"SU ";:RETURN
680 IF J=1 PR"MO ";:RETURN
690 IF J=2 PR"TU ";:RETURN
700 IF J=3 PR"WE ";:RETURN
710 IF J=4 PR"TH ";:RETURN
720 IF J=5 PR"FR ";:RETURN
730 IF J=6 PR"SA ";:RETURN
740 REM SUBR. PRINT MONTH
750 IF K=1 PR" JANUARY
760 IF K=4 PR" APRIL
770 IF K=7 PR" JULY
780 IF K=10 PR" OCTOBER
790 RETURN
800 REM TAB ASCII-CODE
810 C=#20:D=#0D:E=TOP
820 FOR I=0 TO 3
830 A=#30:A=A+I
840 IF I=0 A=#20
860 FOR J=0 TO 9
870 B=#30:B=B+J
880 @E=A:(E+1)=B:@(E+2)=C:@(E+3)=D:E=E+4
890 NEXT J
900 NEXT I
910 @TOP=#20:@(TOP+1)=#20:@(TOP+128)=#20:@(TOP+129)=#0D
920 GOTO 10
```

>RUN
YEAR? 1981

CALENDAR 1981

	JANUARY	FEBRUARY	MARCH
SU	4 11 18 25	1 8 15 22	1 8 15 22 29
MO	5 12 19 26	2 9 16 23	2 9 16 23 30
TU	6 13 20 27	3 10 17 24	3 10 17 24 31
WE	7 14 21 28	4 11 18 25	4 11 18 25
TH	1 8 15 22 29	5 12 19 26	5 12 19 26
FR	2 9 16 23 30	6 13 20 27	6 13 20 27
SA	3 10 17 24 31	7 14 21 28	7 14 21 28
	APRIL	MAY	JUNE
SU	5 12 19 26	3 10 17 24 31	7 14 21 28
MO	6 13 20 27	4 11 18 25	1 8 15 22 29
TU	7 14 21 28	5 12 19 26	2 9 16 23 30
WE	1 8 15 22 29	6 13 20 27	3 10 17 24
TH	2 9 16 23 30	7 14 21 28	4 11 18 25
FR	3 10 17 24	1 8 15 22 29	5 12 19 26
SA	4 11 18 25	2 9 16 23 30	6 13 20 27
	JULY	AUGUST	SEPTEMBER
SU	5 12 19 26	2 9 16 23 30	6 13 20 27
MO	6 13 20 27	3 10 17 24 31	7 14 21 28
TU	7 14 21 28	4 11 18 25	1 8 15 22 29
WE	1 8 15 22 29	5 12 19 26	2 9 16 23 30
TH	2 9 16 23 30	6 13 20 27	3 10 17 24
FR	3 10 17 24 31	7 14 21 28	4 11 18 25
SA	4 11 18 25	1 8 15 22 29	5 12 19 26
	OCTOBER	NOVEMBER	DECEMBER
SU	4 11 18 25	1 8 15 22 29	6 13 20 27
MO	5 12 19 26	2 9 16 23 30	7 14 21 28
TU	6 13 20 27	3 10 17 24	1 8 15 22 29
WE	7 14 21 28	4 11 18 25	2 9 16 23 30
TH	1 8 15 22 29	5 12 19 26	3 10 17 24 31
FR	2 9 16 23 30	6 13 20 27	4 11 18 25
SA	3 10 17 24 31	7 14 21 28	5 12 19 26

BRK AT 370

>

>

FEBRUARY	MARCH
MAY	JUNE
AUGUST	SEPTEMBER
NOVEMBER	DECEMBER

Anyone who has built the Elekterminal will know that although the keyboard produces the complete set of 128 ASCII characters, the lower case letters are not decoded by the VDU board. This in no way undermines the performance and operation of the Elekterminal, especially as most BASIC computers will only accept upper case characters anyway! However, for certain applications, the addition of lower case letters and graphic symbols can be very advantageous.

lower case and graphics for the elekterminal

Since the Elekterminal was first introduced (Elektor 44, December 1978) many readers have requested a modification to the circuit to enable both upper and lower case characters to be displayed. The 'add on' unit described here goes a step further in that it also allows the production of 'contiguous graphics'.

The modification described here is centred around the 96364 G graphics unit from Auto Electronics. This device is intended primarily as an addition to existing VDU circuits which employ the popular Thomson-CSF SFF 96364 CRT controller (which just happens to be the case in the Elekterminal!). The CRT controller is capable of producing a display of 16 lines of 64 characters (1024 overall) each made up from blocks of 12 rows of 8 horizontal elements. As the CRT is designed to operate with a 7 x 5 dot matrix generator it is clear that the production of proper lower case characters (with descending tails) and contiguous graphics is something of a problem.

The 96364 G graphics unit fits between the CRT and the character generator and expands the row addressing of the CRT to the full 12 rows. This means that the complete 8 x 12 dot matrix for each of the 1024 characters can be accessed. It also means that the standard character generator ROM (2513) becomes redundant.

The ASCII character codes are now stored in a 27xx series EPROM which makes the modification very versatile — a 2708 will store 64 characters, a 2716 will store 128 characters and a 2732 will store 256 characters! This gives rise to the feasibility of custom programming your own EPROM to give you the character display of your choice — even foreign alphabets, such as Arabic, are now possible (cheaply).

The relevant circuit details of the Elekterminal are shown in figure 1a, while figure 1b shows the modifications required. The major component in figure 1b is the graphics unit which effectively decodes the complete row addressing for the character EPROM. The latter simply takes the place of the

previous character generator ROM, IC11 (although not physically!). The remaining new components (N27, N28 and IC22) are included to eliminate any timing problems that may affect the right most column of the character font. There are a number of ways in which the actual modification can be carried out, but as the majority of connections to be made are in the region around IC11 the preferred method is to use a 24 pin 'header' in the socket of this IC. Certain other connections will have to be made to the Elekterminal board itself.

The modifications to the Elekterminal board are shown in figure 2. The first part of the procedure is to 'clear the path' around IC12. As can be seen from the circuit diagram (figure 1b) pins 5, 6 and 11 of IC12 are now used. This means that the copper track between these pins and the zero volt rail must be broken (with a sharp knife!!). Having done this it becomes necessary to rejoin the zero volt rail between pin 9 of IC12 and Pin 12 of IC20 by means of an insulated wire link. Finally, remove the link between pin 2 of IC18 and pin 1 of IC12 (see figure 2b).

The next stage is the actual wiring, which to a (very) small extent depends on the particular EPROM used. If a 2708 is used, the connections marked A and B in figure 1b must be joined to a negative 5 volt supply and a positive 12 volt supply respectively. This may mean an extra (or modified) power supply. If a 2716 is used, then point A must be connected to +5 V and point B (which now becomes an extra address line) can be connected to a switch. This switch will then select between upper case characters and lower case/graphic characters.

Alternatively, to enable both upper and lower case characters to be displayed at the same time, the extra modification shown in figure 3 can be incorporated. This extra modification simply decodes and stores the previously ignored bit 5 and is almost identical to the existing memory circuitry. Unfortunately, a few further connections are required to the main Elekterminal board and the wire link between pin 11 of IC16 (N1) and pin 11 of IC1 must be removed.

The output of N1 (pin 11 of IC16) is now inverted by the new NAND gate N29 before being fed to the data input of the new 2102 RAM IC23. In addition, bit 5 is now fed to the input of N30 which inverts the data input to IC1. This is done so that the entire memory can be filled with the 'space' code (\$ 20) when the 'erase' key is depressed — this function was previously performed by bit 6 and N1. The output of the new RAM (IC23) is connected to an extra D-type flipflop (IC24) before being fed to point B of the graphics generator board. The remaining connections to the new RAM are exactly the same as those for the existing memory ICs.

1a

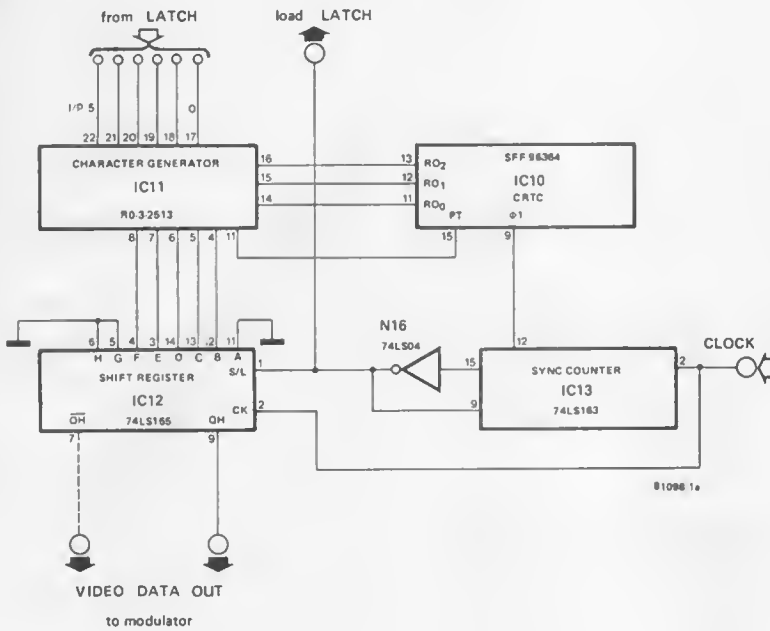

1b

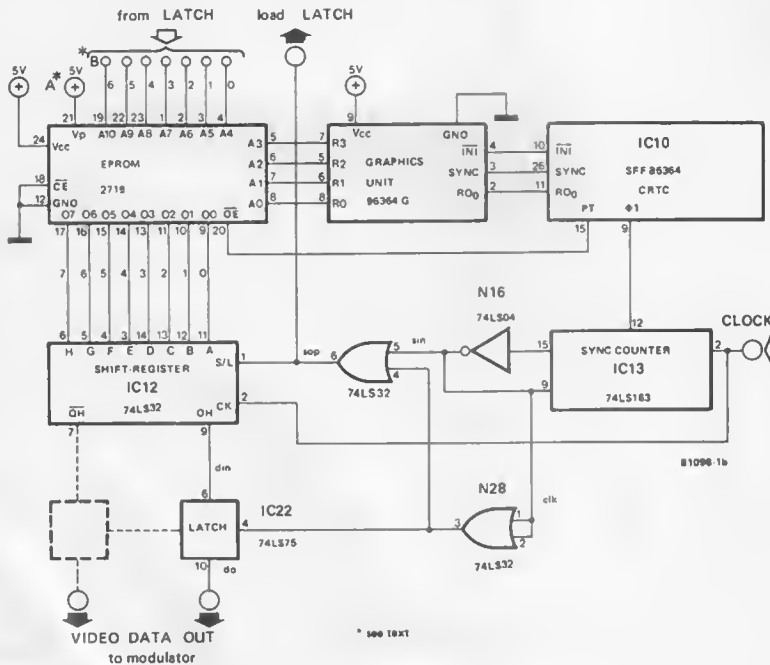

Figure 1a. The relevant circuit details of the Elekterminal.

Figure 1b. The required modification to the Elekterminal circuit.

The same possibilities apply to point B if a 2732 EPROM is used, but this time point A should be connected to a switch as this now becomes a further address line. This switch can then be used to select between upper/lower case characters and graphics, depending on how the EPROM is actually programmed. By the way, the EPROM can even be programmed to display control characters (C/R = carriage return etc.), but this means that IC7 would have to be reprogrammed.

The remaining connections to the graphics board should be fairly straightforward as long as the diagram in figure 2b is followed carefully. The main points to watch are the connections 'clock', 'sin', 'sop', 'din', and 'do'. The rest are simply wired to the pin header which has (or should have) been placed in the socket which previously held the ROM character generator IC11. The only thing that has not yet been mentioned is the actual programming of the EPROM. As stated before, this depends entirely on the required character font. An example of how to program the EPROM for the letter A and the graphic symbol < is shown in figure 4. It should be noted that white dots are programmed as '1' and black dots are programmed as '0'. Using this information it should be possible to program the specific character font of your choice for display on the Elekterminal.

Note: In certain instances (depending on the type of EPROM used) the width of the cursor may be reduced. This problem can be overcome by including pull-up resistors (10 kΩ) between the output lines of the EPROM and +5 V. ■

A complete set of components for the graphics generator board, (figure 2b) ready built printed circuit boards and custom programmed EPROMs are available from; Auto Electronics, Moorend Grove, Cheltenham, Gloucester, GL53 0EX.

2a

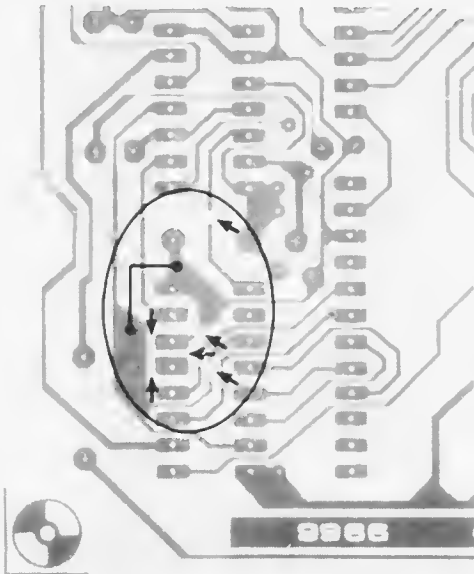

2b

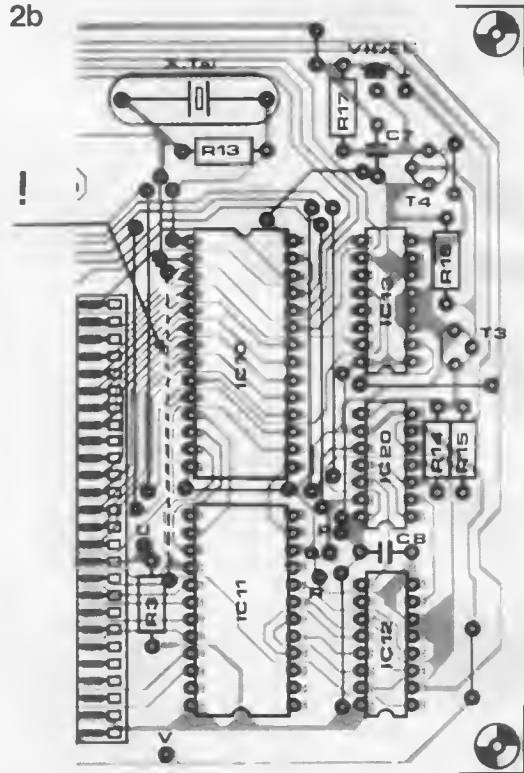

Figure 2a. For the modification, certain areas of the copper track around IC12 have to be broken and an extra link inserted.
 Figure 2b. The link between pin 2 of IC18 and pin 1 of IC12 must also be removed.

3

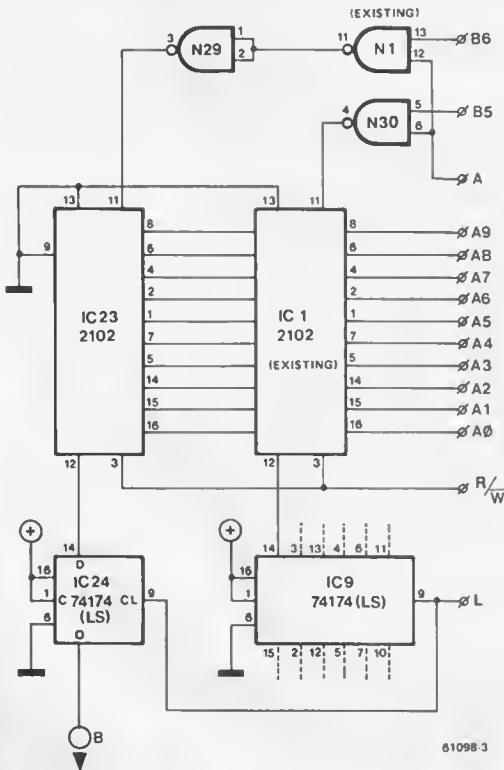

Figure 3. If upper and lower case characters are to be displayed at the same time, this extra circuitry will have to be incorporated.

4

programming for 'A' 0000 = 00 08 14 22 22 3E 22 22 00 00 00 00 FF FF FF FF
 programming for '<' 0010 = 01 02 04 08 10 20 20 10 08 04 02 01 FF FF FF FF

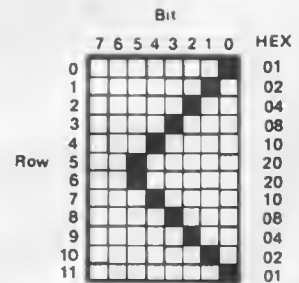
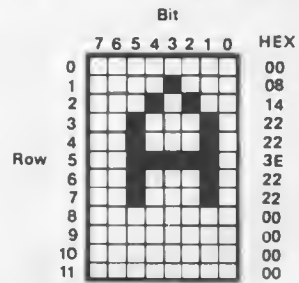

Figure 4. This shows how the EPROM can be programmed to display the characters 'A' and '<'.

market



Multi-mode audio filter

The Datong Multi-mode Audio Filter (Model FL2) adds fully variable selectivity to existing communications receivers without the need for internal modifications. It connects between a receiver and its loudspeaker and contains its own 2 watt audio output stage. Model FL2 is especially effective at removing close spaced interference to SSB, CW or TRRY signals. Its very steep cut-off characteristics give maximum reduction of interference with minimum loss of the desired signal.



and is end-stackable to enable any precise number of connections for a given application. The KR Series is constructed as a dual-row terminal strip of eight terminals each, and has a working voltage of 250 V d.c. In the case of the KR Series, from three to 18 terminations are available and these are arranged in a staggered configuration; the working voltage is 380 V d.c. In all versions of the KR range, the p.c. terminations are arranged in the industry standard 5 mm grid format.

*H & T Components,
Crowdy's Hill Estate,
Kembrey Street,
Swindon,
Wiltshire SN2 6BN,
Tel.: Swindon (0793) 693681-7,
Telex: 444166.*

(1714 M)

Selectivity is controlled by three separate audio filters which are tuned independently or together depending on the operating mode. In the SSB mode two five-pole elliptic function filters are used as independent low and high pass filters with very steep cut-off while a separate two-pole filter is used for notching. All three filters feature continuous linear tuning from 200 to 3500 Hz so that optimum results can be obtained under any given set of interference conditions.

In the 'CW' mode all twelve poles of filtering are used in combination under the control of non-interacting 'centre frequency' and 'bandwidth' controls, and give exceptional skirt selectivity.

*Datong Electronics Limited,
Spence Mills,
Mill Lane,
Leeds LS13 3HE,
Tel.: 0532 552461.*

(1722 M)

Terminal blocks for pcb applications

H & T Components announce the introduction of a completely new range of single-row terminal blocks specifically designed for flow soldering onto a printed circuit board.

Known as the KR Range, these new and highly compact terminal blocks are produced in three forms: the KRE, for standard applications; the KRD, for high density interconnections; and the KR, which offers higher power handling capabilities. Each consists of a grey flame retardant (group O) plastic body containing culmo tinned brass terminals, which incorporate a socket with integral captive screw and solder-tag p.c.b. terminals. With a working voltage of 280 V d.c., the KRE Series offers from two to 18 terminations

market

Precision d.c. motors

Micro Communications recently announced the availability in Europe of a new range of high quality, high reliability d.c. motors, and tachometers, manufactured by Dynetic Systems Inc. of Minnesota, USA.

Designed to the highest quality standards, every motor is dynamically balanced, functionally tested, run non-stop for 24 hours, then re-tested for torque and speed prior to dispatch.

A number of standard products are available, covering motor diameters from 1½ to 2¼ inches, but 'specials' can be undertaken for larger production runs.

These units can be used in computer peripherals, machine tools, cameras, pumps, office and medical equipment.

Some of the range of motors/tachometers by

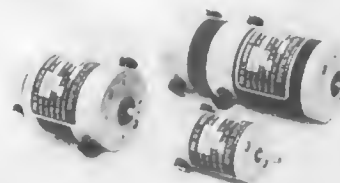

Dynetic Systems is illustrated in the photograph.

1. MHBT-2229

A high performance motor-tachometer with a speed of 7000 - 12000 rpm. The tachometer can provide a voltage output proportional to speed.

2. TG-1500

A low ripple dc tachometer-generator, capable of speeds up to 10,000 rpm.

3. MHPT-2200

A high performance servo motor — tachometer with output ripple comparable to a moving coil — but less expensive.

*Micro Communications,
10 Laurel Drive,
Tilehurst,
Reading RG3 5DY,
England,
Tel.: (0734) 413891*

(1724 M)

Morse tutor

The Datong Morse Tutor (Model D70) is a unique and low-cost training aid for Morse Code operators at all levels of skill from beginner to expert. It provides programmed learning and allows individual users to develop at their own pace. Portability and long internal battery life allow the unit to be instantly available even outside formal training periods.



The unit generates a completely random continuous sequence of variable speed code in five character groups. Most important however a separate control introduces an extra variable delay between letters. Thus by having a long delay between characters even a beginner can learn code characters with their normal high speed sound pattern. As skill develops the trainee reduces the extra delay until, when the 'CAL' position is reached, the code has correct spacing for the chosen speed. The same functions are equally useful for helping professional users to maintain proficiency or to develop their speed further.

*Datong Electronics Limited,
Spence Mills,
Mill Lane,
Bramley,
Leeds LS13 3HE,
Tel.: 0532-552461.*

(1711 M)

market

market

New 4½ digit multimeter

Thurlby Electronics Ltd. have announced the introduction of the model 1503 4½ digit LCD multimeter at a price more commonly associated with 3½ digit meters.

The 1503 has an unusually long scale length of 32.768 counts (± 15 bits). This gives it greater resolution than 4½ digit meters, and contributes to the meter's extremely good worst case accuracy figures.

Thirty measuring ranges are provided covering the five basic functions of DC and AC voltage, DC and AC current and resistance. In addition, diode test and crystal controlled frequency measurement up to 3.9999 MHz are included. The 1503 has very high sensitivity figures of 10 μ V, 10 m Ω and 1 nA, and an input impedance of 1 G Ω can be selected as an alternative to the standard 10 M Ω . Maximum voltage input is 1200 volts and currents can be measured up to 25 amps.



The case is high impact ABS with a six-position tilt stand/handle. Although intended as a laboratory instrument, its low power consumption enables 200 hours of battery operation for field use. Accessories supplied include the AC line cord and standard test leads. Price in the U.K. is £ 139.

*Thurlby Electronics Ltd.,
Coach Mews, St. Ives, Huntingdon,
Cams, PE17 4BN.
Telephone: (0480) 63570.*

(1772 M)

New Weller EC2000 soldering iron

The Weller EC2000 features electronic control of the soldering tip temperature in the 185°C to 450°C range. Temperature setting and tip temperature are displayed on a three digit LED readout with a resolution and setability of $\pm 1^\circ$ C.

Ideal for the most sensitive electronic circuitry, the Weller EC2000 comprises a small portable bench-top power unit with integral holder for the handy soldering iron. Temperature settings and tip temperatures are displayed by means of a selector switch which can be positioned in 'set' or 'read' positions. The temperature setting is adjusted by merely turning the control knob until the desired figure is displayed with the switch in the 'set' position.

The electronic system utilises power control



with zero voltage thyristor drive. This ensures that no high voltage spikes or magnetic fields will be present on the soldering tip. In addition, the power unit is isolated from the AC line by a transformer and only 24 V AC isolated voltage is used to drive the heating element. The tool tip is earthed through the power unit three wire cord.

A full range of Weller ET series tips is available for use with the EC2000 to suit any application.

*Cooper Tools Limited,
Sedling Road, Wear, Washington,
Tyne and Wear NE28 9BZ.*

(1769 M)

market

Illuminated push buttons

IMO Electronics have now introduced a series of illuminated push button switches and indicators — designated type number 01.00. The advanced design of these switches enable engineers to create a set of products with an attractive panel appearance which combines both reliable switching and ease of operation, and offer clearly displayed control functions. They are available in six lens colours with a concave legend surface with space for up to 44 characters.

Available in low profile bezels, the screens and lamps are easily replaced from the front of the panel and are compatible with DIN 43700 and measure only 24 x 18 mm. They have a small behind panel depth and can be mounted in lines across or vertically, through a 16 mm diameter hole.

Alternate or momentary action types are available, with 1 and 2 changeover contacts. The switches are fitted with 5 amp 240 V AC silver on copper contacts with brass silver plated 2mm terminals for either solder or faston no. 150635.2 push on connectors.

The life of the switch is in excess of 10 million operations and will give satisfactory operation in a temperature of -25° C to $+60^\circ$ C in a relative humidity of 80%.



The button is brightly illuminated by a T1½ 1.2 watt midget groove bulb available in operating voltages of 6, 12, 24 (28), 48 and 60 V DC. The switch case and contact assembly are constructed of polycarbonate and the button is made of cellulose, acetate, butyrate (CAB) allowing a high degree of resistance to petrol, oil, grease and aromatics.

*IMO Electronics Limited,
349 Edgware Road,
LONDON W2 1BS.
Telephone: 01.723.2231/4.*

(1766 M)

market

market

X/Y recorder

The new 3054 X/Y recorder from Gould Instruments Division is a rugged and versatile general-purpose/laboratory instrument which combines fast response and high sensitivity. Fourteen pushbutton-selected sensitivities from $200 \mu\text{V}/\text{cm}$ to $5 \text{V}/\text{cm}$ accommodate a wide range of input signal amplitudes, while the fast response enables the instrument to record fast-changing signals for applications such as transient signal analysis and destructive testing.



The 3054 offers a slewing speed of 85 cm/s minimum, Y-axis acceleration of 7700 cm/s^2 , and an X-axis acceleration of 5100 cm/s^2 . The 12.5×17.5 -inch writing table of the 3054 features silent electrostatic paper hold-down and edge lights for fast, consistent positioning of both 11×17 -inch and 8.5×11 -inch chart paper or their DIN A3 and A4 equivalents. A disposable felt-tip pen provides up to 3300 ft (1000 m) of high-quality, skip-free traces at writing speeds of more than 120 cm/s . Local and remote penlift is provided.

The X- and Y-axis preamplifiers for the Gould 3054 include calibrated zero offset in five pushbutton-selected steps from $\pm 100\%$ to $\pm 500\%$ of full scale, and a pushbutton-selected low-pass filter providing 12 dB/octave attenuation starting at 5 Hz. Calibration zero offset allows the user to suppress the static portion of an input signal so that its dynamic portion can be amplified by a maximum amount for detailed examination. The low-pass filter enables the user to exclude unwanted noise or high frequency components from the preamplifier outputs so that the recorded traces will contain a maximum of meaningful information with a minimum of extraneous interference.

Other features of the Gould 3054 include floating and guarded inputs at front and rear for recording from both grounded and ungrounded sources at all signal levels; high input impedance ($1 \text{ M}\Omega$) to avoid the loading of input sources; and 500 V maximum input voltage on all sensitivity ranges.

The DC servosystem in the 3054 is electronically protected against both off-scale input signals and potential drive-motor

burnout resulting from physical blockage of the carriage. In addition, the pen-position feedback potentiometer in this system never needs lubrication.

An optional timebase module for the Gould 3054 can be supplied as an integral part of the unit. It provides six timed ramp voltages causing sweeps of 0.25, 0.5, 2.5, 5, 25 or 50 s/cm which can be applied to either axis to produce X/T or Y/T plots. The timebase module provides automatic reset at the end of a scan, and also has a unique scan-width control feature to accommodate the size of chart used or the amount of the chart that the user wishes to cover.

Gould Instruments Division,
Roebuck Road,
Hainault, Essex.

(1770 M)

Microprocessor controlled digital thermometer

The KM 10,000 series just announced by Kane-May Limited provides numerous facilities not previously available with hand-held units.

Developed for industrial and scientific applications, the 10,000 series provides high accuracy throughout the range: minus 213°C to plus 1820°C ($\pm 0.2^\circ\text{C} \pm 0.1\%$ reading between 25° to 300°C and $\pm 1.5^\circ\text{C} \pm 0.1\%$ reading between 1370°C to 1820°C). Resolution is 0.1°C between -200°C and $+200^\circ\text{C}$ and 1°C outside this range.

Conversion of displayed values from Centigrade to Fahrenheit, or from Fahrenheit to Centigrade, can be instantly effected at the touch of a button. In the Fahrenheit mode, resolution is 1°F at all times.

Other functions touch selectable from the calculator-style keyboard include constant monitoring and storage of maximum and minimum probe temperature, memory storage of any displayed temperature, memory recall of this value, and display of the value of probe temperature minus the temperature stored in the memory.

Microprocessor control provides indication in the display panel of the function selected and automatically warns of over and under-ranging of a particular thermocouple, broken thermocouple, or incorrect entry of a difference value.



Additionally, KM 10,000 constantly carries out a range of integral self-test routines which, in a fault condition, automatically provides a numerically coded indication in the display panel, to aid fault diagnosis.

The new thermometer is housed in an impact resistant ABS case to withstand hard industrial use, and has a 10 mm liquid crystal display with automatic back lighting. Power is from re-chargeable batteries.

Kane-May Limited,
Burrowfield, Welwyn Garden City, Herts.
Telephone: Welwyn Garden 31051.

(1764 M)

New work holder

An ingenious new product from Tele-Production Tools Ltd. is a work holder with a 'quick-release' trigger which allows PCB boards to be removed and replaced in a matter of seconds. Unusual too are the special attachments which fit to the PCB holding arms and which can be repositioned to hold such small components as switches etc., during soldering operations.

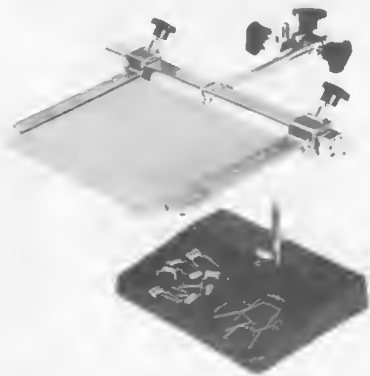

The MPC-2 work holder can hold boards up to 12 inches long, is multipositional and can revolve 360° . The 'quick-release' trigger arm works by spring tension which is adjusted by means of a knurled knob. The heavy die-cast base of the work holder incorporates two trays for holding components and other small parts.

Tele-Production Tools Ltd.,
Sitron House, Electric Avenue,
Westcliff-on-Sea, Essex, SS0 9NW.
Telephone: (0702) 352719.

(1762 M)

market

market

Sifam to market toroidal mains transformers

A comprehensive range of single-phase, high efficiency, toroidal transformers with ratings from 10 VA to 1300 VA is now being marketed in the UK by Sifam Ltd., the moving-coil meter and panel accessory company of Torquay, Devon.

The development follows an agreement with Polytronik GmbH of Munich, giving Sifam the exclusive UK franchise for the German company's products.

Polytronik specialise solely in the design and manufacture of toroidal transformers, and claim to offer one of the most comprehensive ranges in Europe at competitive prices.

Sifam say that the performance advantages of toroidal transformers are now widely accepted by most user industries in electrical, electronic and general engineering fields. These include: high capacity from very compact and light-weight units, extremely low magnetic leakage and high efficiency.

Previously, however, these benefits have been offset by higher prices. Now, with the cost advantage gained from specialised high-volume production plants such as that operated by Polytronik, toroidal transformers are, according to Sifam, cost-effective for practically any application.

Standard Polytronik transformers are available from stock in two basic constructions: open type with heat-resistant insulation banded covering the full range up to 1300 VA, or waterproof 'potted' up to 200 VA. Both are supplied with exposed coil ends, but there is also a potted stock range up to 50 VA fitted with plug terminations for use in printed circuits. Various frames, bush mountings and other assembly accessories are also available.

Efficiencies range from 83 per cent at 10 VA

rated load up to 96 per cent at 1300 VA. Standard transformers are wound for 240 V, 50 or 60 Hz, but other voltages and frequencies can be catered for, as can special primary or secondary winding or tapping arrangements.

*Sidam Limited,
Woodland Road,
Torquay, TQ2 7AY.
Telephone: 0803 (Torquay) 63822.*

(1765 M)

VDU and keyboard enclosures

The Vero Group of Companies, are launching a brand new range of low cost, VDU and keyboard enclosures.

Known as the 'Saturn' range, they are aimed at systems builders who, because of escalating design, development and tooling costs, require high quality, 'Off the Shelf' housings for their monitors and keyboards.



The range, which has been designed to accept electronic components and assemblies from a wide selection of original equipment manufacturers, consists of a monitor case which will house a 12" CRT (Cathode Ray Tube), a monitor case which will house 15" CRT units and a peripheral case which complements the VDU enclosures by providing storage for mini floppy disc drives, modems and other ancillary equipment. The tops of all three enclosures can be removed for easy access: ventilation is provided by the provision of slots in the top

and bottom mouldings. Additional ventilation may be provided in the 12" end 15" CRT enclosures by installing a standard fan in the base unit. The range is completed by two keyboard enclosures, which will accommodate a variety of keyboard arrangements and sizes. These are sold complete with a metal front panel which can be tailored to suit specific requirements.

All of the units in the 'Saturn' series are manufactured in moulded thermoplastic, high impact polystyrene structural foam and are attractively styled in a two-tone grey colour scheme.

*Vero Electronics Limited,
Industrial Estate, Chandler's Ford,
Eastleigh, Hampshire, SO5 3ZR.
Telephone: (04215) 66300.*

(1765 M)

Compact codeswitch

The Model C5 codeswitch, the latest addition to the IVO range, features an easily read character display with figures 6mm high housed in a compact modular case.

Coding required for any situation is set by operation of positively acting pushbuttons; one advancing the code wheel, the other reversing it a digit at a time.

Switches offering a choice of five different output codes can be supplied; decimal (0-9), BCD, BCD complement, duodecimal (0-12) and plus/minus.

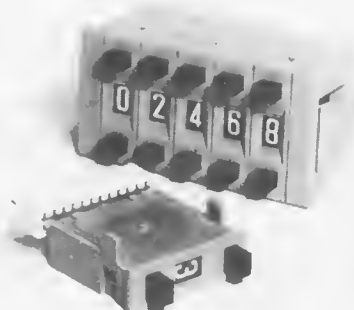

Individual switch modules are snapped together, as required, to form multiple assemblies and end-plates, carrying integral clips, provide for mounting directly into panel cutouts. Electrical connection to the switches is made via solder tags or optional push-on connectors.

The C5 codeswitch complements the models C3 and C4 codeswitches already available from IVO counters.

*IVO Counters Limited,
351 Morland Road, Croydon, CR0 6HF.
Telephone: 01-656-9565.*

(1768 M)



market

ELEKTOR BOOK SERVICE



SC/MPUTER (1) — describes how to build and operate your own microprocessor system — the first book of a series — further books will show how the system may be extended to meet various requirements.

Price — UK£3.70 Overseas £3.90

FORMANT — complete constructional details of the Elektor Formant Synthesiser — comes with a FREE cassette of sounds that the Formant is capable of producing together with advice on how to achieve them.

Price — UK£4.50 Overseas £4.70

300 CIRCUITS for the home constructor — 300 projects ranging from the basic to the very sophisticated.

Price — UK£3.50 Overseas £3.70

DIGIBOOK — provides a simple step-by-step introduction to the basic theory and application of digital electronics and gives clear explanations of the fundamentals of digital circuitry, backed up by experiments designed to reinforce this newly acquired knowledge — supplied with an experimenter's PCB.

Price — UK£5.00 Overseas £5.20

BOOK 75 — a selection of some of the most interesting and popular construction projects that were originally published in Elektor issues 1 to 8.

Price — UK£3.50 Overseas £3.70

When ordering please use the Elektor Readers' Order Card in this issue (the above prices include p. & p.)