

elektor

up-to-date electronics for lab and leisure

66
October 1980

ISSN 0308-308 X
U.K. 60p
U.S.A. \$2

slide control

touch doorbell

switched capacitors

up-to-date filters in a single IC



selektor	10-01
programmable slide fader (C.R. Wijnen)	10-05
More often than not nowadays two projectors are used at once during slide shows. This does mean however that the operator can be very busy, for not only must he operate the slide fade system and the change mechanism, but he is also expected to provide background music, the commentary, and fulfill all the other activities involved in a slide show. The programmable slide fader described in this article enables all the necessary information for projectors to be included on the cassette containing the commentary and music.	
touch doorbell (Robert L.A. Trost)	10-10
All manner of doorbell variations have been published in Elektor and yet no attention has ever been paid to that little pushbutton at the side of the front door which announces a visitor. We think it is time an electronic alternative to the mechanical switch currently in use was found.	
switched capacitors	10-12
'Chips with everything' seems to be the slogan for electronics in the eighties. If you think we're exaggerating just take a look at this new recipe from the electronics heute cuisine: switched capacitors in integrated form. Ideal for making highly compact and 'steep' filters and by 'steep' we mean with edges of 30-100 dB per octave!	
more TV games	10-17
There is still a distinct lack of ready-made software for the Elektor TV games computer and therefore the introduction of the new ESS cassette (ESS 007) will be welcomed as a major step in the right direction. This article gives an idea of the programs available and describes some further software tricks.	
the junior computer memory card	10-22
The memory expansion card described last month contains a total of 8K of RAM and up to 16K of EPROM. This card was designed to be used with the SC/MP or Junior Computer. In the case of the latter, however, the address decoding must be expanded further and the present article explains how this is possible.	
remote control slide projector	10-24
Although the use of remote control in a slide show can lead to a much smoother presentation, the combination of feet and cables can 'stop the show' rather abruptly. An ultrasonic control will therefore add considerably to the advantages of a remote control projector by removing the major disadvantage.	
video pattern generator (P. Needham)	10-28
Design and construction of high quality video pattern generators is not an easy task for the amateur, but if 'reasonable' quality is acceptable there is no need for the TV enthusiast to go without.	
LCD tuning scale	10-32
If a tuner is to look at all up to date, it will require a digital tuning scale. Thanks to continuing progress in miniaturisation the reader is now able to add a little luxury to his receiver with a minimum of components and at a very low cost. A single IC, one crystal and a liquid crystal display is just about all that is needed in the circuit presented here.	
dual slide faders (P. de Bral)	10-36
The circuit for a dual slide fader published in the March 1980 issue of Elektor suffers from one main disadvantage, namely that it will not change slides automatically on projectors with this facility. In this article the dual fader is combined with a control circuit to provide slide changing on two projectors.	
market	10-39
advertising index	UK-22

contents

content

cont

con

EDITOR:

W. van der Horst

UK EDITORIAL STAFF

T. Day E. Rogans
P. Williams

TECHNICAL EDITORIAL STAFF

J. Barendrecht
G.H.K. Dam
P. Holmes
E. Krempelsauer
G. Nachbar
A. Nachmann
K.S.M. Walraven



**DMM
BREAKTHROUGH**

If you want an Autoranging 3½-digit LCD DMM For only **£39.95**

(inc VAT)

We've got to hand it to you!

- * ZERO ADJUSTMENT
- * 3½-DIGIT LCD WITH
200 HRS CONTINUOUS
BATTERY LIFE
- * AUTO 'BATT'
WARNING
- * FULL AUTORANGING
- * AUTO UNIT DISPLAY
- * CONTINUITY TEST
(6110 and 6100 only)
- * 10 AMP AC/DC (6110
and 6220 only)

Introducing the latest professional state-of-the-art 3½-digit DMM - at really old-fashioned prices! From just an unbelievable £39.95 inc. VAT, plus £1.15 p&p!

	6100	6110	6200	6220
RESOLUTION	Low 12A, 0.1V, or 0.1mΩ			
FULL AUTO-RANGING	✓	✓	✓	✓
RANGE HOLD	✓	✓	✓	✓
UNITS OF MEASUREMENT DISPLAYED	mV, V, mA	mV, V, mA, A	mV, V, mA	mV, V, mA, A
FUNCTIONS DISPLAYED	Ω, KΩ, AUTO, BATT, ADJ, LO, - and AC			
MEASURES DC VOLTAGE TO	1000V	1000V	100V	1000V
MEASURES AC VOLTAGE TO	750V	750V	750V	750V
MEASURES AC DC CURRENT TO	300mA	10A	200mA	10A
ZERO ADJUSTMENT	Zero set in built test sockets for precise measurements			
ACCURACY	±0.5%	±0.5%	±0.8%	±0.8%
LOW POWER OHM-RANGES	For in-circuit resistance measurements on all models			
BUZZER - Continuity Test	✓	✓	✓	✓
BUZZER - Over Range Indicator	✓	✓	✓	✓
COMPLETE WITH	Batteries, pair of Test Leads, Spare Fuse, One Year 1 Guarantee			
PRICE	ONLY £64.95	ONLY £74.95	ONLY £39.95	ONLY £49.95
p&p	£1.15	£1.15	£1.15	£1.15

Why such a low, low price? Because the A/D converter and display are custom built! This is a genuine top-spec DMM. Check these features for unbeatable value - you won't find a hand-held DMM with these features at these prices again!

I believe you! Please send me the DMM's as marked

_____ 6200 @ £41.10 each, inc VAT, p&p Total price £ _____
 _____ 6220 @ £51.10 each, inc VAT, p&p Total price £ _____
 _____ 6100 @ £66.10 each, inc VAT, p&p Total price £ _____
 _____ 6110 @ £76.10 each, inc VAT, p&p Total price £ _____

Total cash/cheque enclosed £ _____
 Cheques payable to
 Maclin-Zand Electronics Ltd - please

Available exclusively from the company that gives
 you tomorrow's technology today
 38 Mount Pleasant, London WC1X 0AP
 Tel 01-278 7369/01-837 1165

ACCESS orders taken. Please write card no and signature

ACCESS NO. _____ 

Name _____

Address _____

Signed _____

ME

Maclin-Zand

Making state-of-the-art affordable

To: Maclin-Zand Electronics Ltd, 38 Mount
 Pleasant, London WC1X 0AP
 Dispatch by return. For overseas orders, please
 add £5 to cost of total order package

1E

selektor

Lightning hazards in the air

On average, aircraft in regular service are struck by lightning about once a year. Nevertheless, the damage is usually negligible and aeroplanes remain very safe compared with other forms of transport. But the problem of protecting them against lightning is becoming more difficult through the growing use of composite materials instead of aluminium alloy structures and with increasing dependence on complex electronic systems, which are particularly susceptible to disturbance or break-down under induced transient voltages and currents. Simulation techniques have been devised at Culham Laboratory to analyse the effects of lightning on aircraft and to provide safety tests.

Hazards

Statistically, aircraft are a very safe form of transport. Usually, if lightning strikes one the damage is negligible. On average, aircraft in regular service are struck once a year; normally, a few burn marks and slight pitting of the metal skin are the only lasting signs, though the strike

itself may be startling. Sometimes there is more severe structural damage, and strikes to the fuel vents or fuel jettison pipes are distinctly dangerous. Electrical and electronic systems, too, are particularly susceptible to damage. The latest aircraft rely on complex electronic systems, including computers, for communication, navigation and other essential tasks. Even the flight of future aircraft may be controlled through electronic systems guided by an on-board computer. Obviously, interference with such equipment must be avoided.

The problem of protecting aircraft has become more difficult with the introduction of new light-weight materials which replace the aluminium alloy used hitherto. A metal skin affords far more protection than glassfibre or carbonfibre composite materials do. To understand the hazards, we must consider what happens when lightning strikes an aircraft.

The first diagram shows the base of a thundercloud, a region of high potential where there are strong electric fields through electric charge, usually negative, produced in the cloud base. When the field is strong enough, there is an electrical break-down and a bright channel grows out of the cloud, advancing in steps towards the ground along a tortuous path that shows frequent branching. This is called a stepped leader. Any aircraft close to the cloud may become part of the channel, in which case it carries the current pulses

that flow as the leader advances. When the leader reaches the ground it forms a bridge between cloud and ground, and a heavy current pulse flows back up the channel and through the aircraft. This is the first return stroke, typically carrying 30 kA (kiloamperes). It causes intense and rapid heating in the channel, which becomes very bright as the pulse passes, and expands rapidly. This expansion causes thunder.

Sometimes, after a pause of a few hundredths of a second, another, faster leader and another return stroke appear, and they may be repeated several times. In a severe storm up to thirty re-strikes have been recorded, though the average throughout the world is about three. The peak current in re-strikes is typically 10 kA. After the last return stroke, a current of several hundred amperes continues to flow for a few tenths of a second; it occasionally appears between earlier re-strikes too. The whole event is called a lightning flash.

Relative Movement

In the course of one strike the aircraft moves significantly with respect to the arc channel. The attachment points of the arc might not change if the channel were strictly axial, as shown in part (a) of the diagram in figure 1b but channels lying at an angle to the nose or the wing-tips, as in (b) and (c), would move backwards with respect to the aircraft, so that successive positions of the forward attachment point would appear

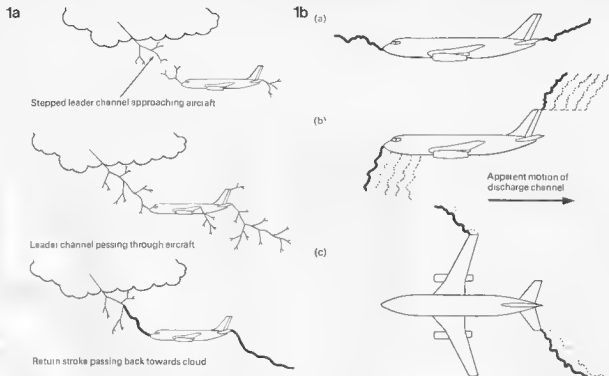


Figure 1a. How an aircraft becomes part of the lightning channel.

Figure 1b. Relative motion of a lightning channel with respect to an aircraft. (a) Lightning stroke in flight path does not sweep aft but tends to keep to original attachment points; (b) Stroke in vertical plane sweeps aft; (c) Stroke in horizontal plane sweeps aft.

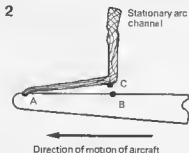


Figure 2. Following original attachment at A, the channel transfers to B when the electric potential across CB is big enough to break down the gap.

as shown by the dotted lines. The rear attachment point cannot move backwards, but some extension of the channel would take place.

The arc attachment point does not slide back continuously. After the aircraft has moved forward, the arc channel takes the form shown in an oversimplified way in the diagram above. The section AC extends until the potential, or voltage drop along it, is big enough to break down the gap BC, whereupon the attachment transfers from A to B. The distance AB is called the step length. Lightning produces a series of attachments along the fuselage or across a wing which follow the air flow roughly, with steps between that vary a great deal. Where these are painted surfaces, the step lengths are longer because the potential along each step must break down the insulation imparted by the paint.

At trailing edges, where further movement of the attachment points becomes impossible, the arc hangs on to the rearmost conductor available to it. The remaining current pulse flows into that point, and it is there that the most severe arc damage occurs. The longest possible hang-on time is taken to be the time between restrikes, for the rapid rise of current in a restrike causes very large induced voltages along every section of the channel, invariably producing new attachment points elsewhere. The generally accepted figure for this maximum time is 50 milliseconds.

Zones

The surface of the aircraft can be divided into three zones taking account of the behaviour of the attachment points. The first attachments take place in what we call zone 1 (see figure 3), which includes all the sharp extremities of the aircraft. Areas into which the attachment points may sweep are defined as zone 2: they lie in the slip-stream behind the forward zone 1 areas. Remaining surface areas, making up zone 3, are unlikely to undergo direct attachments but may carry lightning currents between attachment points, so in these regions, too, some

effects of lightning may be seen. The diagram shows an example of zoning for a typical aircraft.

Every flash differs from all other flashes. Statistics about the peak current, the rise time of the current pulse, the charge transferred and other data have been painstakingly gathered in many countries. Sometimes positive charge escapes to ground, and very often discharges between clouds occur that never transfer any charge to ground. Internationally-agreed standard current waveforms for testing aircraft and aircraft components have been developed on the basis of the characteristics of ground flashes, because they are considered to be the more severe.

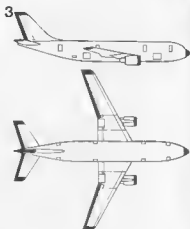
Types of Damage

Damage caused directly by the passage of lightning current includes melting, evaporation and eroding of metal; deformation of structures by magnetic forces and shock waves, and sparking. Very little energy is needed to ignite an inflammable mixture of fuel vapour at a fuel vent. Fortunately, the conditions under which the appropriate mixture of vapour and air is likely to be present are rather rare, but fuel vents are always placed in zone 3 in modern aircraft designs because of that risk.

Indirect effects of lightning are of two kinds. The first arises when the current pulse flows in a continuous metal conductor, such as a metal aircraft without windows or gaps of any sort in the skin. Fast-rising currents flow at first only on the outer surface. The current diffuses into the skin relatively slowly, and a voltage pulse appears later on the inner surface. Its magnitude is determined by the skin thickness and conductivity, the shape of the aircraft, and the form of the current pulse. Such a voltage pulse is injected into electrical circuits connected to the inside of the



Photo 1. Arc-damage test rig with symmetrical current feed.



Zone 1 Zone 2 Zone 3

Figure 3. Typical zones for classifying lightning attachment points.

aircraft skin. The voltage is small with metal skins but large with certain composite ones.

Breaks in Skin

Other indirect effects appear because the aircraft skin is not continuous: the changing magnetic field due to the lightning current penetrates air gaps or apertures covered by electrical insulators such as glass, perspex or glass-fibre composite materials, so voltages are induced in circuits that lie underneath breaks in the metal skin; the size of the voltage depends on the rate of rise of the lightning current and on the position of the circuits. With careful design and good screening the induced voltages can be made small enough to be harmless, but dangerous voltages may arise in badly-placed electrical systems.

In certain recently-designed aircraft, metal skins have been partially replaced by carbon-fibre-reinforced plastic

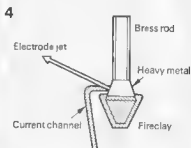


Figure 4. Specially-developed electrode to prevent molten metal from the electrode spraying on to the surface that is under test. The electrode arc spot is confined to the surface of a cone facing away from the test specimen, so the jet of electrode metal sprays away from the specimen and does not disturb the arc root.

materials. These have advantages where light, stiff structures are needed but their electrical resistance is about a thousand times that of metals. The direct damage done in carbon-fibre composites when a lightning current pulse flows is therefore likely to be much greater than in metals. Damage at an arc attachment point is also severe. Neither type of direct damage appears when glass-fibre composites are used, unless they are punctured by lightning, for they are true electrical insulators.

Indirect effects in circuits underneath panels of carbon-fibre composites are nearly as great as if the panels were absent, or made of glass-fibre composites. The penetration of the magnetic field is nearly as fast as through an open aperture. Very high voltages appear across carbon-fibre panels momentarily, but the current soon moves into neighbouring metal if a parallel path can be found. Voltages inside an aircraft made entirely of carbon-fibre composite might be much higher than those inside metal aircraft. Great care must be taken to protect electrical equipment and wiring when composites are used, especially if digital electrical systems are involved.

Simulation

Specially-designed generators enable standard test-current waveforms to be produced in the laboratory. High voltage capacitor banks, charged to 20 kV and 100 kV, supply current to an inductive energy store for studying direct effects, the first use of inductively-stored energy in lightning tests. Other new techniques that have been developed include feeding the current to an arc via multiple



Photo 2. Aircraft fuselage mounted in a quasi-coaxial conductor system for indirect-effects testing, allowing panels of various materials and sizes to be fitted.

5

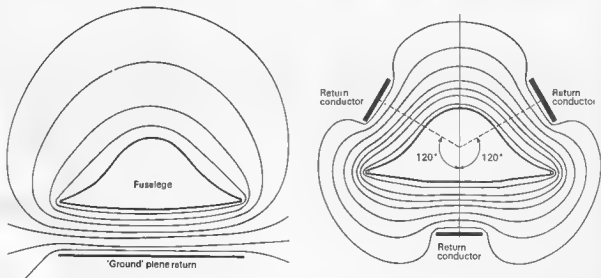


Figure 5. Distortion of magnetic field through using a closely spaced, single return conductor. Right: quasi-coaxial three-conductor system for the return current, giving a realistic computed field distribution.

paths. In photograph 1 the inner conductors of six coaxial cables are extended to surround a central arc; current flows up the conductors and down the centre lead to the arc. The base plate holds the specimen and the current returns to the source via the outer screens of the coaxial cables. The whole system is balanced so that the currents flowing in the cables are the same and there is no net magnetic field at the arc. If such precautions are not taken the arc is moved by the residual magnetic field of the current leads and unrepresentative damage occurs, invalidating the test.

Another important point in tests on damage at the arc root is that metal vapour from the electrode facing the test surface must not spray on to that surface. A jet-diverting electrode has been developed to confine the electrode arc spot to the surface of a cone facing away from the test specimen. The electrode metal then sprays away from the specimen and does not disturb the arc root that is under study. For studying indirect effects a low-inductance 1-MV capacitor band is used. This type of generator is necessary to produce the high rates of rise of current that is needed; the load circuit, too, must be of low inductance. In addition, the current distribution around the aircraft studied must be the same as if that

aircraft were remote from all other bodies if a good simulation of a lightning stroke is to be obtained. If a single, wide, metal strip is used as the return conductor for a current pulse along the fuselage, the magnetic field around the fuselage is stronger near the return conductor than elsewhere. Computations of the field distribution for this configuration give the contours of magnetic flux shown in figure 5. Three symmetrically-disposed conductors give a realistic computed field distribution, and this was confirmed by experiments. Computations for an isolated body gave magnetic fields very close to those in the diagram. Part of an aircraft has been mounted in such a quasi-coaxial system. Tests on cables in the aircraft are excellent simulations of lightning strikes, and panels of various materials and of realistic sizes may be mounted on the aircraft for test purposes.

Precautions

When making measurements, elaborate precautions have to be taken against interference from spark gaps, open arcs and so on. The diagnostic circuits must be carefully placed to eliminate the risk of electrical break-down in the sensitive measuring equipment. The output signals are displayed on oscilloscopes and photographed, or fed into a transient

digitiser for further analysis. Data analysis systems are expected to become more important in the future, as the high-frequency behaviour of electronic equipment in aircraft struck by lightning becomes more important.

From experience gathered over the last eight years, advice may be given on many aspects of lightning protection for aircraft and, for that matter, on problems on board ships and in ground installations. Progress in this field is greatly helped by the good international co-operation between lightning research institutions and testing centres in many countries.

Source: Dr. P.F. Little,
Culham Laboratory,
Oxfordshire
in *Spectrum* No. 167/1980

(577 S)

elektor

up-to-date electronics for lab and leisure
requires

A TECHNICAL EDITOR

to be responsible for the edition of our English language (monthly) magazine and books at our head office in Beek (L), The Netherlands.

The successful applicant should have English as his/her native tongue, and preferably a degree (or equivalent) in electronics and considerable experience as an editor. A good working knowledge of either Dutch or German is essential.

Please send detailed curriculum vitae to:
Mrs. Van der Horst, Elektor B.V.,
Postbus 75, 6190 AB Beek (L), The Netherlands.

programmable slide fader

Slide shows on tape

C.R. Wijnen

More often than not nowadays two projectors are used at once during slide shows. All that is needed is an efficient control system for the pictures to fade into each other on the screen. This does mean however that the operator can be very busy, for not only must he operate the slide fade system and the change mechanism, but he is also expected to provide background music, the commentary, and fulfil all the other activities involved in a slide show. A programmable slide fader enables all the necessary information for the projectors to be put on tape or on cassette. It could even be included on the cassette containing the commentary and music.

Most readers will have returned from their holidays by now and are no doubt eager to show their holiday snaps and slides. Of course slides can be shown quite easily with the aid of a manually operated projector, but after all the less work that is involved for the person running the show, the better, for then he/she too can relive the vacation. In any case, if every slide is to be changed by hand, the whole procedure may take up an entire evening. This can be avoided by making use of two projectors and varying the brightness of each in turn so that the pictures can be made to fade into each other. If, in addition, the whole system can dispense with wires, there is nothing to prevent you from enjoying the show.

This article describes a complete slide fade unit changing slides automatically and enabling a slide show to be preserved for posterity on tape/cassette memory.

The block diagram

Figure 1 gives the block diagram of the programmable slide fader. In order to create an efficient slide fader, four controls are needed: two brightness controls and two switches to operate the change mechanism of the two projectors. The state of these controls over a particular time span must be registered on tape as accurately as possible, which is why it seems logical to select a digital system. To start with, the required brightness of each projector (an analogue value) must be converted into a digital value. This is done by means of an analogue/digital (A/D) converter. Since the data must be examined for one projector at a time, it will have to be indicated for which projector that information is meant. Finally, another two signals are required to change the slides (again, one per projector).

These data must now all be converted from parallel to serial information. This occurs inside block P/S. A transmit circuit adds start, stop and control bits to it and then sends the signal obtained to the tape recorder receive circuit. The latter decodes the entered signal so that the original eight bit serial information is left. At the end of a serial/parallel conversion (S/P) the digital information will have to be translated back to signals that are comprehensible for the projectors. By means of a D/A converter the 'digital brightness' is converted into an analogue voltage, the value of which determines the point on the mains waveform where the triac in the lamp circuit starts to conduct. The two outputs for the slide change each control a relay. Complexity is kept to a minimum by the use of a UART (Universal Asynchronous Receiver/Transmitter). This means that blocks P/S, transmit —

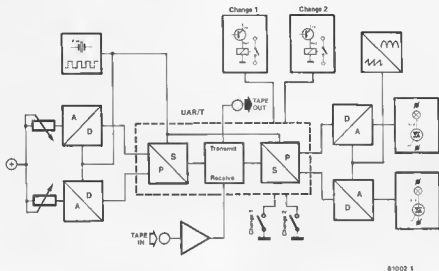


Figure 1. The block diagram of the slide fader circuit. It shows that the UAR/T is of great importance here.

receive and S/P are all contained in a single IC.

The circuit

The full circuit diagram is shown in figure 2. This may seem fairly complicated, but will become clearer with explanation. The UAR/T and the A/D converter require an oscillator. This consists of N1, N2 and a 1 MHz crystal. The gate N5 serves as a buffer. The 100 kHz clock frequency required is obtained by dividing the oscillator output by ten with IC12. If a 100 kHz crystal is available, then IC12 can be 'linked out' on the printed circuit board. Unfortunately a 100 kHz crystal is rather difficult to obtain and is in any case much more expensive than a 1 MHz.

To the far left of the circuit diagram are the two brightness control potentiometers P1 and P2. These are connected directly to the A/D converter consisting of MMV1, MMV3, FF1, FF2 and IC3. This section converts the setting of the potentiometers into 5 bit binary value. Each of the two monostable multivibrators (MMV1 and MMV2) is triggered alternately by the flipflop FF1. The procedure is as follows. When the UAR/T (IC4) transmits a character (8 bit parallel information) a TM8T pulse is generated at pin 22. This (via N3) causes the D type flipflop FF1 to change state. This in turn triggers monoflop MMV2, for instance. The counter, consisting of IC3 and FF2, will count clock pulses for the pulse duration of MMV2. In other words, the time that the counter will count for is determined by the RC time

constant of MMV2 — set by C5 and potentiometer P1. After a maximum of 32 clock pulses the count total (the position of the counter) will be accepted by IC4, the counter will be reset and FF1 will change state so that MMV1 will now be triggered and counting will start for F2. The data input D5 of IC4 is connected to the Q output of FF1 and the presence of either a 1 or a 0 will determine for which projector the information available at that particular moment is meant. To change the slides in projector 1 and 2 respectively, pushbuttons S1 and S2 are used. They are connected to inputs D7 and D8 of IC4.

As has already been seen during the description of the block diagram, the UAR/T IC4 contains various circuits. There are eight inputs for parallel information, D1...D8. This data leaves in a serial form via S0, which takes 1.92 ms. This bit pattern passes to the 'tape out' output and, with S4 in the position drawn, to the serial input S1. After a serial-parallel conversion the information will again be available at the RD1...RDB outputs to be converted into control signals for the projectors. Outputs RD7 and RD8 each control a relay via a transistor to change slides.

To convert the 5 bit signal for the brightness, use is made of two D/A converters, consisting of IC5, IC6, R20...R24 and R29...R33. Depending on the logic level of output RD6, the information of RD1...RD5 is latched to the outputs of either IC5 or IC8. If, for instance, IC5 (if RD6 is low) receives the first character, then the next character will be directed (by RDB being high) to IC6, then IC5

again and so on. The resistor network at the outputs of IC5 and IC6 produces an analogue voltage which is equal to the available binary value.

The triacs are controlled by three comparators of an LM339. A1 generates a sawtooth wave which is synchronous to the supply frequency. The sawtooth wave is connected to the inverting inputs of A2 and A3. The control voltages representing the brightness of each projector are at the non-inverting inputs of these comparators. The moment at which the triacs start to conduct depends on the moment at which the sawtooth voltage is equal to that of the D/A converters.

The dual stage amplifier (T1, T2 and surrounding components) is the tape playback amplifier and ensures that a symmetrical square wave signal will be presented to the S1 input. This will of course only happen when S4 is in the other position. Lastly, the simple power supply uses the well known 7805 voltage regulator.

Construction

Figure 3 illustrates the printed circuit board. All the components are included on the board except for the switches, potentiometers and the transformer. The components should not prove difficult to mount, but a few suggestions will help.

For P1 and P2 it is advisable to use slide potentiometers. These are easy to control and practical. Micro switches can be used for S1 and S2, and mounted at the end of the sliders. In this way the micro switch will close when the corresponding potentiometer reaches

zero and the slide will automatically be changed whenever the light of the projector in question goes out. Instead of two separate potentiometers, a single stereo version may be used. Then however it will no longer be possible to operate the projectors individually. The above remarks only concern projectors which have two buttons for operation of the transport: one button for forwards and one for reverse. In the case of a single button version (press briefly: forwards, hold button: reverse) this system cannot use micro switches. Then two pushbuttons will have to be used to change the slides. The slide projectors must meet these requirements: they must be remote controlled and have a 24 V/150 W lamp. There are two ways to connect the projector lamps to the controls:

1. The triacs are mounted on the printed circuit board. This means that one of the lamp leads in the projector will have to be divided and the two cables brought out to the board. It is advisable to use thick cables not more than three feet long (they may have to carry up to 6 amps). The triacs have to be provided with heat sinks, as they dissipate some 8 W each.
2. The better method: mount the triac and heat sink into the projector, if possible near the fan. The lamp is connected in the same manner as given under point 1. Now two thin cables may be led out and these do not need to be so short. They will be for the gate and terminal 2 of the triac. This method has the advantage that less energy is dissipated. The relay contacts are connected in parallel to the pushbutton contacts of the remote control system. Another possibility is to use a separate connecting cable.

Testing and setting up

With S4 on 'manual' the brightness of each projector should be able to be controlled with P1 and P2. Slides are changed by depressing S1 or S2. It may happen that when regulating the brightness the projector lamp goes out before the potentiometer reaches the end of its travel. This means the monoflop time is too long so that the counter is able to count more than 32 pulses and therefore is reset to zero. This may be avoided by placing a resistor of 180...220 k across the potentiometer. By means of 'tape out' the entire procedure (fading in and out, changing the slide and the time that a slide is projected on the screen) may be put on tape. The recorder used must be good quality and at least meet the DIN 45500 standard, as otherwise the digital signal might not be well reproduced.

P3 must now be adjusted for optimum reproduction. With the aid of an oscilloscope this pot is set so that the length of

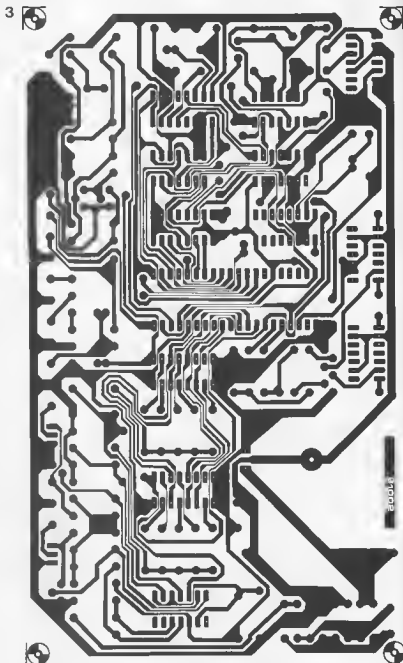
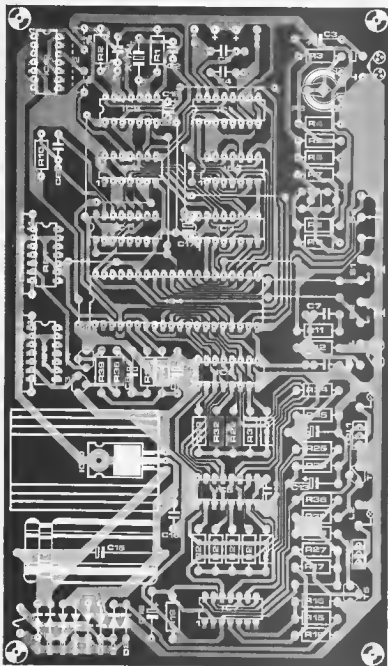


Figure 3. The printed circuit board and copper layout. When using a 1 MHz crystal, the 1a and 1b connections must be made; when using a 100 kHz, however, IC12 is omitted and connection 2 is made.

Parts list	
Resistors	R25, R34 = 27 k
R1 = 2k	R26, R35 = 56 k
R2, R18 = 2k2	R28, R37 = 220 Ω
R3, R5, R23, R32 = 47 k	P1, P2 = 50 k LIN
R4, R10, R21, R27, R30, R36 = 10 k	P3 = 10 k preset pot
R6 = 120 k	Capacitors:
R7, R8 = 1 k	C1, C4, C5 = 10 n
R9, R24, R33 = 100 k	C2 = 470 p
R11 = 68 k	C3 = 4μ7/63 V
R12, R13, R14, R22, R31, R38, R39 = 22 k	C6 = 390 p
R16, R20, R29 = 4k7	C7 = 68 n
R15, R19 = 5k6	C8, C9 = 2μ2/63 V
R17 = 15 k	C10 = 15 n
	C11 = 12 n
	C12, C13, C14 = 2μ2/63 V
	C15 = 2500 μ/16 V



C16 = 100 n
C17, C18 = 2µ/2/35 V tantalum

Semiconductors:

T1, T2, T5, T6 = BC547B
T3, T4 = BC557B
TR1, T/2 = TIC 226
D1, . . . D4 = 1N4001
D5, . . . D8 = DUS
IC1 = 74221
IC2 = 7474
IC3 = 74191
IC4 = AY-3-1015
IC5, IC6 = 74174
IC7 = LM339
IC8 = 74LS00
IC9 = 7402

IC10 = 7805
IC11 = 74123
IC12 = 7480

Miscellaneous

Tr1 = mains transformer primary
220 V, secondary 8 V/1 A
F1 = fuse 100 mA, with fuse holder
S1, S2 = pushbutton switch
S3 = double pole switch
S4 = single pole toggle switch
crystal 1 MHz (100 kHz)
Rel, Re2 = DIL reed relay

the incoming pulses (at T2's output) corresponds to those sent by the UAR/T. If no scope is available, P3 may be preset during several trial recordings until the circuit works well in the playback phase. It must be taken into account that the input circuit's sensitivity is 2 V_{eff}. Thus, 'tape in' must be connected to a headphone output or something similar.

As far as the recorder is concerned, it may well give a phase shift of 180° between input and output. Then no results will be obtained at all even if you adjust P3 until you're blue in the face! The solution is to change round the 'tape in' connections. If this proves necessary, the taping and playback cable cannot be connected at the same time, as then the tape recorder's output would be connected to ground by means of its own input. Thus, the playback plug must be removed during taping, and the taping plug during playback. This can of course also be done with a switch, so that the plugs don't have to be removed at all.

Operation

After reading the above, operation should pose no problems, so that a brief summary should make things sufficiently clear.

Taping. S4 in position 'manual', regulate brightness with P1 and P2 and change slides with S1 and 2.

Playing back. S4 switched to 'tape' position. When using a stereo recorder, the control data can be recorded on channel 1 with commentary and music recorded on channel 2. This will give a much smoother presentation.

As a result of all this effort, you will be able to put on a highly professional slide show. Unfortunately, we have yet to develop a slide fader to make up for poor quality pictures! **M**

electronic pushbutton

Robert L.A. Trost

touch doorbell

All manner of doorbell variations have been published in Elektor and yet no attention has ever been paid to that little pushbutton at the side of the front door which announces a visitor. We think it is time an electronic alternative to the mechanical switch currently in use was found.

Even the most futuristic doorbells — and quite a few have been published in Elektor in recent years — are operated by the familiar pushbutton. A modern doorbell which can play a melody or imitate a bird requires something a little more up-to-date. A touch switch would be more appropriate but for one reason or another is not usually thought of during the design. However, this article proposes to remedy this.

also of course for various other switching functions. The 7555 is used, the CMOS version of the well known 555 timer. The first of these (IC1) is wired as an astable multivibrator with an output frequency of about 200 kHz. This output signal is fed to rectifier D1/D2 via the touch switch (which is in fact a capacitor). The rectified signal charges C3 so that the signal level at pin 2 of IC2 becomes high. In this condition IC2 will not be triggered and, because its output (pin 3) will be low T1 will not conduct. When touching the sensor, the human body represents a capacitance to earth which is a low impedance for a relatively high frequency. This will prevent the output signal of IC1 from reaching the rectifier. C3 will then be discharged by R3 and, as soon as the voltage across C3 drops below half the value preset by P1, IC2

will therefore provide the supply voltage for the circuit while the doorbell is being rung.

The quiescent current consumption will only be about 400 μ A. Even so, this is still too high for a battery supply. Not counting the current consumption while the doorbell is being rung, two 4.5 V batteries can only last about 200 days and this would mean changing them two or three times a year. If it is decided that batteries will be used then the bridge rectifier will not be required.

Generally speaking, the touch switch should not be difficult to build, especially if use is made on the printed circuit board available from Elektor's EPS service. The sensor can be manufactured from double sided circuit board material. If required, thin perspex covered in copper foil may also be used

The circuit diagram

Figure 1 gives the circuit diagram of a universal touch switch which is particularly suitable for doorbells, but

1

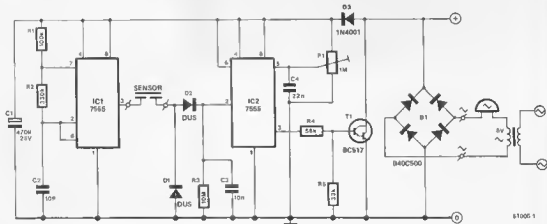


Figure 1. The complete diagram of the touch doorbell. Since CMOS IC's are used, current consumption is low.

2

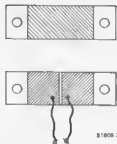
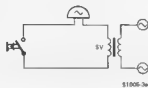
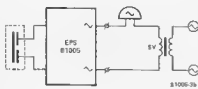


Figure 2. This is what the sensor should look like. The shaded areas are of copper. The front panel consists of a single plate, whereas there are two plates at the rear where the connections to the circuit board are attached.

3a



b



c

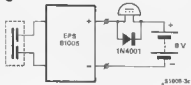


Figure 3. 3a shows a traditional bell circuit. 3b illustrates how the touch switch substitutes the push button. In 3c a diode must be mounted across the bell to protect T1, as the bridge is not required if a battery supply is used.

as indicated in figure 2. The connections between the sensor and the printed circuit board must be kept as short as possible. The darlington T1 can switch about 250 mA, which is sufficient for most types of bells. In exceptional cases, T1 may be replaced by a BD 679, although then a bridge with a higher current rating will be needed.

The connections

The pushbutton for a normal doorbell

4

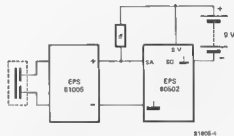


Figure 4. If the touch switch is combined with the 'musical box' published in the September issue of Elektor, an additional resistor will be necessary.

5

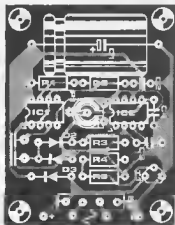
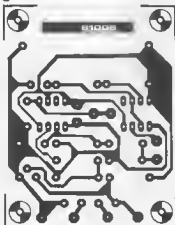


Figure 5. The layout of the touch doorbell printed circuit board.

Parts list

Resistors:

R1 = 100 k
R2 = 330 k
R3 = 10 M
R4 = 56 k
R5 = 33 k
P1 = 1 M

Capacitors

C1 = 470 μ /25 V
C2 = 10 p

C3 = 10 n
C4 = 22 n

Semiconductors:

D1, D2 = DUS
D3 = 1N4001
B1 = B40C500 (40 V 500 mA)
T1 = BC 517
IC1, IC2 = 7555

Miscellaneous:

sensor as figure 2
bell (see text)
bell transformer

system (figure 3a) is replaced by the touch switch as indicated in figure 3b. If a battery is chosen as a supply, as mentioned previously, then a bell that will operate on DC must be used and this needs to be bridged with the aid of a diode to protect T1. The diagram for this is given in figure 3c.

In the September issue a circuit was published for an electronic musical box which could also be used as a doorbell. If one wishes to combine this circuit

with the touch switch, it can be connected as shown in figure 4. The wires between the circuit board and the rest of the circuit are not restricted to any particular length.

Finally it must be ensured that no moisture can bridge any of the three copper surfaces of the sensor. This will have to be taken into account when fixing the sensor to the door — or when selecting the type of door!

Signals are filtered in every possible branch and application of electronics. In every case certain signals have to be selected for a special purpose: for instance, radio and television broadcasts depend on the ability to single out one transmission at a time from a jumble of several. Electronic methods are used to filter out any interfering signals as effectively as possible. As a result a whole arsenal of high pass, low pass, band pass and elimination filters has been built up. Designs with famous names such as *Butterworth* and *Chabychev*.

Even so, progress continues to be made. Recently *active filters* were introduced. By using more amplifier stages (now much cheaper thanks to semiconductor technology) the difficulty of coils can be avoided. This has highly beneficial effects, especially with low frequencies — in audio for instance — where coils are often quite expensive and sensitive to interference.

up-to-date filters
in a single IC

switched capacitors

Integration is 'in'! Soon discrete components will have become extinct. 'Chips with everything' seems to be the slogan for electronics in the eighties. If you think we're exaggerating just take a look at this new recipe from the electronics haute cuisine: switched capacitors in integrated form. Ideal for making highly compact and 'steep' filters and by 'steep' we mean with edges of 30-100 dB per octave! Even though these IC's are by no means 'readily available' as yet, this article provides a few practical filter circuits for enthusiasts.

Active filters use resistors and capacitors apart from the amplifier stages. The latter, of course, are incorporated in IC's, so that these present few problems. In the case of the resistors and capacitors however care is needed with layout and assembly. It would be ideal if they too could be included in an IC together with the amplifiers. Unfortunately, this is not as easy as it sounds.

Technically speaking, it is in fact possible to incorporate resistors in an IC, but only if their values are low. Higher values take up far too much room on the chip. Since the cost of an IC is directly related to the area of the substrate, it will be obvious that resistors formed in this manner would be very uneconomical. For this reason they are usually replaced by current source circuits, but these are not suitable for filter applications. As for capacitors, finding them inside an IC is very rare indeed. This is because a value of a few pF also occupies a fair amount of silicon. Thus, the combination of both resistors and capacitors in a single IC seems as yet a far cry from reality. Especially as certain types of filter require either the capacitor values or the resistor values to be fairly high. This is necessary to reach a certain time constant (the RC time).

Now an elegant solution for these design problems has been found in the form of switched capacitor filters (SCF). It is based upon the principle: *replace a large resistor by a small capacitor*.

This may sound a little strange, but it is possible, as shown in figure 1. Figure 1a gives the resistor we wish to replace.

On one side there is a voltage u_1 , on the other a voltage u_2 . For simplicity's sake it will be assumed that u_1 is greater than u_2 . Then a current i will pass through resistor R from left to right. According to Ohm's Law:

$$R = \frac{u_1 - u_2}{i}$$

Back and forth

Figure 1b constitutes the 'imitation resistor'. Switch S continually switches back and forth between u_1 and u_2 . The frequency at which that happens is called f . Whenever S is in position a the capacitor C is charged to the voltage level u_1 . Whenever it is in position b it is discharged to the level of u_2 (still assuming u_1 to be greater than u_2). This enables a charge to be transferred from u_1 to u_2 , which is exactly what a resistor does, only a resistor is used with a constant current, whereas

the switched capacitor operates in stages. However, as long as the switch frequency f is high enough, you won't notice the difference.

The 'resistance' of the switched capacitor as shown in figure 1b is easy to calculate. The moment switch S switches from position a to b C is charged to the level u_1 . This means that the charge in C (according to the definition of a capacitor) will be equal to $C \cdot u_1$ (coulomb). As soon as S switches from b to a, C is charged to the level u_2 and the capacitor will contain a charge equal to $C \cdot u_2$. In other words, switching S back and forth from u_1 to u_2 causes a charge quantity to be transferred, which is:

$$C \cdot u_1 - C \cdot u_2 = C(u_1 - u_2)$$

As the switching frequency is f , S switches f times back and forth per second. The charge transfer per second will therefore equal $C(u_1 - u_2)f$. And charge (transfer) per second is identical to current. Thus, $i = C(u_1 - u_2)f$, which when included in Ohm's Law produces:

$$R = \frac{u_1 - u_2}{C(u_1 - u_2)f} \text{ or}$$

$$R = \frac{1}{C \cdot f}$$

This equation is not only valid when u_1 is greater than u_2 but also when it is smaller, since neither u_1 nor u_2 appear in the formula (they are cancelled out). This can already be deduced from figure 1b as the layout is completely symmetrical.

How a large resistor can turn into a small capacitor

Equations aren't always as satisfying as this particular one. In the first place this is due to the capacitor C 's value being in the denominator. Thus, the larger the resistance a switched capacitor is required to produce, the smaller the capacitor needed. Since it is impractical to include a resistor in an IC when it is large, the integration of a small capacitor in its place is readily acceptable. In practice, the required chip surface area may be a thousand times smaller.

The second advantage is provided by the frequency f in the denominator, for now a *frequency-dependent resistor* has come into being. As you will see this offers very interesting possibilities, such as voltage controlled filters or 'tracking filters'.

The RC network

A third reason for favouring the formula which substitutes a switched capacitor for a resistor is that filter circuits — like a great many other circuits — often involve highly complicated and long-winded formulae. However complicated the formula is, it will always include RC products if it is a circuit built up from resistors and capacitors. Let us suppose the R in the product is replaced

by a switched capacitor of $\frac{1}{C_1 \cdot f}$ and

that a capacitor worth C_2 is chosen for the C , the value of the RC product (τ) will be:

$$\tau = \frac{C_2}{C_1} \cdot \frac{1}{f}$$

A capacitor value is present both in the numerator and in the denominator. If such a 'resistor' and capacitor combination is integrated it provides two advantages. The value of the RC product is not directly dependent on those of the capacitor but on the ratio of two capacitors. Integrating one capacitance of a highly precise value is not easy, but the ratio of two capacitors can be accurately established thanks to the photolithographic techniques used to make IC's. This has to do with the fact that during integration the surface areas of capacitor plates are under strict control, whereas the density of a dielectric is not. Thus, an accuracy of up to 1% and even 0.1% may be obtained.

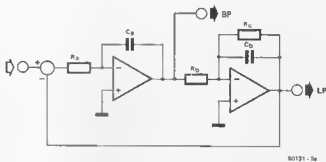
The second advantage is that all sorts of capacitor drawbacks cancel each other out. Their temperature and voltage dependencies, for instance. Really there is no need to try to obtain an as low as possible temperature and voltage dependency, for deviations will merely cancel each other out. Especially as the temperature dependence of 'real' resistors is no longer involved, a switched capacitor filter has a temperature stability of a rare quality.

1

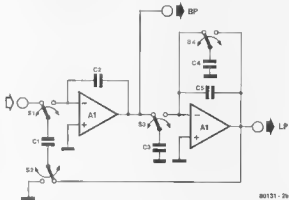


Figure 1. Resistor R in figure 1a may be replaced by the circuit in figure 1b, provided switch S switches to and fro between a and b at a sufficiently high frequency.

2



80131 - 2a



80131 - 2b

Figure 2. The principle of switched capacitors as applied in a state variable filter. The circuit in figure 2a can be replaced by that of figure 2b to be incorporated in a single IC. BP and LP stand for band pass and low pass respectively. High pass and band elimination filters may be made in a similar fashion.

Not all that glitters . . .

Of course there are disadvantages as well. A very important one to start with is the switching frequency. It was seen that this must be 'high'. Sampling is involved and so the well known 'sampling theorem' also applies to switched capacitor circuits. This states that the highest frequency to be processed may be no higher than half the switching frequency. In practice, this means switched capacitor filters in IC form — where the switches are replaced by MOSFET's — may be used

up to 50 kHz. In any case, the audio range limit is well below that.

A filter circuit

Figure 2 illustrates how the principle of switched capacitors may be applied in a real filter circuit. Figure 2a provides the general layout of a 'state variable' filter. Depending on the component values chosen it can have Butterworth, Chebyshev or other characteristics. The filter has two outputs: one indicated as BP (band

Table 1.

Data concerning:

R 5609 low pass filter (elliptic, seven pole, six zero points)

R 5611 high pass filter (Chebyshev, five poles)

R 5612 notch filter, four poles

positive supply voltage (V_+)	4 ... 11 V
negative supply voltage	-4 ... -11 V
supply current	6 ... 11 mA type 9 mA
clock voltage	CMOS/TTL compatible
peak frequency R 5609	0,1 ... 25,000 Hz
R 5611	0,1 ... 8,000 Hz
notch frequency R 5612	0,1 ... 5,000 Hz
clock frequency to notch frequency ratio	
R 5609 97 ... 103 type 100	
R 5611500 ... 530 type 515	
R 5612900 ... 960 type 930	
input impedance	> 1 M Ω
input capacitance	< 15 pF
maximum output voltage	12 V _{pp}
maximum output current	4 mA
dynamic output impedance	< 250 Ω
output noise R 5609	< 2,5 mV
R 5611	< 1,0 mV
R 5612	< 1,5 mV
dynamic range R 5609	> 75 dB
R 5611, R 5612	> 80 dB
total harmonic distortion	< 0,3%

pass), and one marked LF (low pass). Thus, the 'state variable' filter is both a band pass and a low pass filter.

In figure 2b the same circuit is supplied with switched capacitors, S3 and C3 substitute R_b , S4 and C4 substitute R_c . Around C1 the circuit is a little different: together with the two switches S1 and S2, C1 constitutes a switched capacitor circuit called a 'differencer'. It replaces R_a and the summer shown in figure 2a. Thus, the resistor is not the only component which can be imitated with the aid of switched capacitors. There are a great many more and even a self-inducting coil can be simulated.

A thing of the present

Figure 3 proves that switched capacitor filters can already be realized. It is an amazingly simple circuit diagram and yet it consists of a low pass filter with a variable switching frequency and an edge of not less than 100 dB per octave (see the frequency graph in figure 4). The circuit's focal point is IC1, the R 5609 manufactured by Reticon. The IC will not yet be available at every electronics dealer, but it is being delivered. Its price will be around £18, which is a lot for an eight pin DIL IC, but chicken feed for 100 dB/octave filter!

What is remarkable is that the IC requires no external components at all. IC2, P1, the three capacitors and the switch merely serve to generate the control voltage for the electronic switches. The frequency of this control signal is between 97 and 103 (typically: 100) times the filter's peak to peak switching frequency. With the components provided the peak to peak frequency may be preset between

3

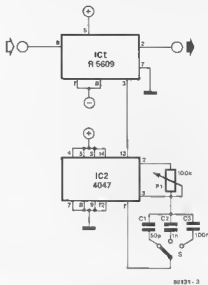


Figure 3. An amazingly simple circuit consisting of a low pass filter with a variable peak frequency having a large range and a filter slope of not less than 100 dB per octave.

4

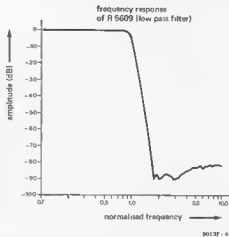


Figure 4. The frequency curve of a low pass filter with a variable peak frequency constructed by means of an R 5609 and a square wave oscillator.

about 0.5 Hz and 25 kHz! S is the range switch.

The circuit can easily be converted from a low pass filter to a high pass filter. All you have to do is replace the R 5609 by an R 5611. High pass filters are a little more difficult to make using switched capacitor technology than low pass filters. Not only does this affect the price, putting it up by several pounds, but the filter slope will be slightly less pronounced (approximately 30 dB per octave, see figure 5, nonetheless a respectable figure). The frequency of the control signal in the R 5611 must be selected 500 to 530 times higher than the desired peak-to-peak frequency.

Changing the circuit in figure 3 into a notch filter is also a simple procedure. Instead of R 5609, use an R 5612. The 'desired' frequency will then be suppressed by about 55 dB (see figure 6). The control signal frequency to elimination frequency ratio will be about 930.

The signal output at pin 4 of the R 5612 (see figure 7) is a square wave at half the clock frequency. This signal can be used to control a second notch filter with a notch frequency of half that of the first filter. A whole row of notch filters switched in series in this manner constitutes a *harmonic comb filter*. This blocks components including the frequencies f , $2 \times f$, $4 \times f$, $8 \times f$... in

5

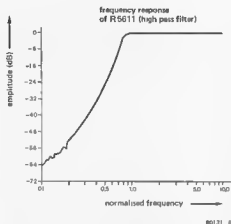


Figure 5. If the R 5609 in figure 3 is replaced by an R 5611, a high pass filter with this frequency curve is obtained. The filter edge is 30 dB per octave.

6

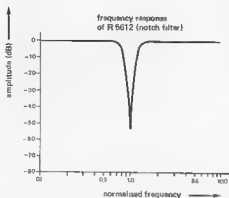


Figure 6. Instead of the R 5609 an R 5612 may be used to produce a band filter suppressing the 'desired' frequency by about 55 dB.

other words: the signal with the frequency and all its upper tones. This means that such a signal will not only be suppressed when it is a sine wave, but also when it has any other (periodical) form.

Tracking filter

Switched capacitor filters like the R 5609, the R 5611 and the R 5612 of course have all sorts of interesting applications. They make building a voltage controlled filter (VCF) child's play. All that is necessary is to control them with the aid of a voltage controlled oscillator (VCO) for which there are numerous circuits.

7

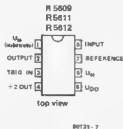


Figure 7. The pin connections are the same for the R 5609, the R 5611 and the R 5612. At pin 4 there is half the frequency of the control voltage enabling a second band elimination filter to be controlled. This is useful when suppressing higher harmonics.

A less obvious application is to use it as a tracking filter. Figure B provides the circuit diagram of a low pass tracking filter using the R 5609. In this case its peak frequency concurs with the fundamental frequency of the input signal. The peak frequency may be exactly as high as the input frequency, or it may be higher or lower in a fixed ratio.

The control signal for the R 5609 is derived from a VCO (voltage controlled oscillator). This is included inside a PLL (Phase Locked Loop), where the frequency is compared to that of the filter's input signal. Between the PLL and the VCO there is a divider circuit, so that the frequency of the VCO will constantly be N times as high as that of the input signal. Between the control signal's frequency and the filter's peak frequency there is also a fixed ratio; the R 5609's peak frequency will therefore always correspond to that of the input signal. If $N = 100$ the peak frequency will be continually equal to that of the input signal. The same principle may of course apply to the R 5611 and the R 5612.

A highly interesting circuit is created when a harmonic comb filter including several band elimination filters (R 5612) is made to lock, for then the most significant component and all its upper tones may be removed from a very complicated signal. Such circuits are used in medical electronics where it is sometimes necessary to separate very weak signals (such as brain waves) from strong interference.

Spectrum analyser

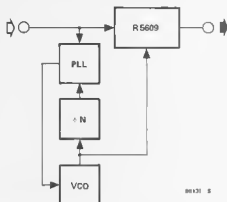
One circuit based on the filtering principle is the spectrum analyser. Switched capacitors are likely to lead to the 'one chip spectrum analyser' within the near future. Although that stage has not yet been reached, Reticon already produces several IC's which are eminently suitable for making a spectrum analyser. These include the R 5604, 5605 and 5606. The R 5604 contains three band pass filters, each of which allow one third of an octave in the spectrum to pass. The three pass bands are next to each other, thus forming exactly one octave. To control the three band pass filters only one control frequency is required. The filters' characteristics meet standard requirements made of Instruments used for acoustic measurements. They are, to be precise, six-pole Chebyshev filters.

The R 5605 is a similar IC, only it doesn't contain three band pass filters for a third of an octave each, but two adjacent band pass filters for half an octave.

Lastly, the R 5606 is the simplest filter: it includes a single band pass filter for a whole octave.

Table 2 provides concise technical data for the three IC's. They are fairly expensive, but well worth it.

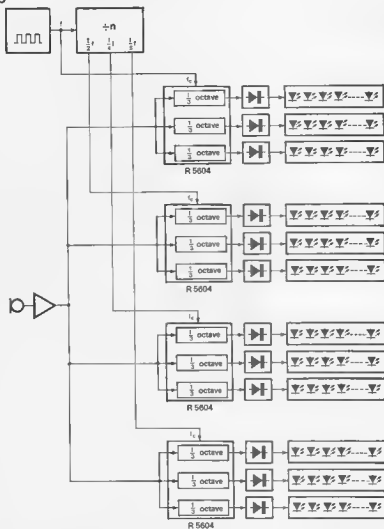
8



80131 8

Figure 8. This block diagram shows how the R 5609 is used as a 'tracking filter'. The peak frequency corresponds to that of the input signal.

9



80131 9

Figure 9. The block diagram of a 'solid state' audio spectrum analyser. The amplified sound is divided by the 1/3 octave filters. The output of each filter is made visible, after rectification, with the aid of an LED thermometer scale.

Table 2.

Data concerning:

R 5604 (3 x 1/3 octave filter)

R 5605 (2 x 1/2 octave filter)

R 5606 (1 x 1 octave filter)

positive supply voltage (V_+) 5 ... 11 V
 negative supply voltage -5 ... -11 V
 clock voltage CMOS/TTL compatible
 middle frequency of the octave 0.5 ... 10,000 Hz

input impedance > 3 M Ω
 input capacitance < 20 pF
 dynamic output impedance 2 ... 10 Ω
 maximum output capacitance load > 50 pF
 maximum output current 4 mA
 output voltage swing 10 V_{pp}
 output noise < 1 mV
 dynamic range > 80 dB
 total harmonic distortion < 0.1%
 temperature drift < 0.002%/°C
 cross talk (R 5604, R 5605) < -50 dB

supply current (type): R 5604 18 mA
 R 5605 12 mA
 R 5606 6 mA
 quality factor (type): R 5604 4.70
 R 5605 3.18
 R 5606 1.73

clock frequency to centre frequency ratio (type)

R 5604 lowest 1/3 octave	135
intermediary 1/3 octave	108
highest 1/3 octave	86.5
R 5606 lower 1/2 octave	108
higher 1/2 octave	77
R 5606	108

Figure 9 shows how these band pass filters could be applied. It is the block diagram of a solid state audio spectrum analyser. Band pass filters have been used rather indiscriminately here. A much more interesting and cheaper circuit could be obtained by using only one band pass filter and 'sweeping' it through the entire audio frequency band by varying the control frequency. Then a kind of multiplex system is created.

The band pass filter described may be used for other purposes as well. For instance in that fascinating new field of electronics belonging to *vocoders* and *synthesizers*. Then there is the second to none in pitch regulation, the *equalizer*. As yet Reticon has not come up with one, but a ten band equalizer on a single chip is being considered...

The four fold programmable switched capacitor filter that has already been included in the Reticon catalogue is intended for microcomputer control. This is especially suitable for the talking and listening computer which is still in the initial stages of development. Thus quite a lot remains to be said about switched capacitors...

Sources:

Reticon (preliminary) data sheets of the R 5604, -05, -06, -09, -11 and -12. The Switched Capacitor Filter: an All Silicon Filter Approach; Reticon Application Note no. 119.

more TV games

over 20 Kbytes on tape

In general, a TV games computer that can only play three or four games soon loses its charm. Fortunately, the Elektor version has the saving grace that it makes it relatively easy to develop your own (games) programs, as more and more readers are discovering. However, there is still the distinct lack of ready-made software. The new ESS cassette (ESS 007), introduced this month, can therefore be seen as a major step in the right direction.

In this article, we will give some idea of the programs available. Furthermore, for true home programmers, we will describe some further software tricks.

The most obvious break with the past is that the new programs are available on tape. There are two good reasons for this. In the first place, most readers use the games computer in conjunction with a cassette deck. Since they are on record, the programs must therefore be transferred to tape for regular use. It seems more logical to supply them on tape in the first place! Furthermore, the cassette interface in the games computer was designed with tape in mind, and it proves to be more susceptible to the kind of errors that occur during playback from a record. The first try (ESS 003) seems to have given quite a lot of problems, and even though the second version (ESS 006) was much better, there is still room for improvement. Our tests so far seem to indicate that the new tapes are virtually trouble-free: using several different decks, all programs run from start to finish without a hitch.

Another advantage of a tape is that it provides room for a large number of programs. An obvious choice, given the file numbering system of the TV games computer, is fifteen programs — corresponding to files 1...F. Some of these are actually improved, 'cleaned up' versions of the more interesting ones on the ESS 003 and ESS 006 records.

File 1: Mastermind

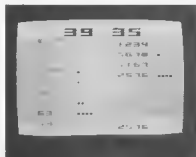
The object of this game is well-known: guess an unknown (colour) code, on the basis of very limited 'feedback'. In this version, purple squares indicate how many correct colours are correctly positioned, and white squares indicate the remaining correct colours in the wrong position. All eight colours are used (black included!), and the same colour may appear more than once in a code.



The computer plays the part of the 'passive' player: it sets up a code, and displays the result of each of your tries.

File 2: Code breaker

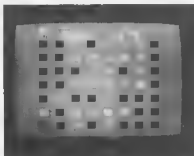
This is the same principle as Mastermind, but the code consists of digits or shapes instead of colours. Furthermore, it is also possible for two players to play simultaneously (each with a different code!), as shown in the photo. Each player's score, and the total number of games played, are displayed at the top of the screen. In all, 24 different variations of the game can be played with the same program.



An interesting point for 'home programmers' to note: when this program is running, the shapes' data (for digits or random shapes) is stored in the monitor RAM area from 0800 on! This is quite permissible, provided no monitor routines are used in the program. The only RAM data that should not be altered is that contained from address 08B9 to 08BF — among other things, this includes the interrupt vector that points to address 0903!

File 3: Reversi

Basically, the object of this game is to capture as many of the opponent's pieces as possible. To do this, you place a piece on the board in such a way that one or more of the opponent's pieces are 'trapped' between two of yours. For example, in the situation shown in the photo a grey square could be placed in the top left-hand corner (second row, second column). This would trap the two squares to its right, so that these can be captured. When captured,



squares change to your colour — they are not removed from the board.

File 4: Amazone

Each 'Amazone' has the capabilities of both Queen and Knight in chess: it attacks squares along horizontal, vertical and diagonal lines, and also any square that can be reached by two horizontal moves followed by one vertical, and vice versa. The players alternately place their Amazone on a square which is not under attack, and which has not been used earlier on in the game. A player loses when there is no legal square left to move, or when he runs out of time.



In this version, the time display consists of the two vertical bars at the left and right of the screen; the score is indicated at the top of the screen. For practice, the game can be played against the computer.

File 5: Space shoot-out

This is an updated version of the game that was originally included on the ESS 006 recording. The object is, quite

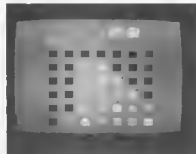


simply, to shoot down the rocket before your time runs out.

A joystick calibration routine has been included, so that the program should run without problems on any TV games computer. Furthermore, it is now an easy matter to modify the time limit and the 'proficiency level': the accuracy required to shoot down the rocket can be varied in three steps from 'beginner's luck' to 'pinpoint'.

File 6: Four in a row

This is the same game that was included on ESS 003. One minor programming 'glitch' has been corrected: in the original version, when a winning row ran down from the top row, only one square would flash instead of all four.



As those who have already tried this program will know, the computer is an infuriatingly skilled opponent.

File 7: Four in a row

Skill comes with practice, and a more challenging game becomes desirable. This version uses an 8 x 7 board, instead of 7 x 6 as in File 6. The extra row and column make quite a difference! It is distinctly noticeable that the computer needs much more time to work out its moves — no trick here, it really is a question of the time it needs for its calculations.



Several readers have asked how the red and green squares are made in this program. Basically, the trick is quite simple. The largest object size is used, and two objects are superimposed for the left-hand half of the screen, the other two being used for the right. Of

the two left-hand objects, one is green and the other red; one shape bit corresponds to one square in the picture. Let us assume now, that the left-hand bit (bit 7) is set in the first row of both objects: the result is a black square in the top left-hand corner of the screen. Resetting this bit in the green object leaves a red square and vice versa. Using the odd rows and odd bits only (1, 3, 5, etc.) produces the display shown.

File 8: Jackpot

This is the well-known 'one-armed bandit'. The rotating drums, 'hold' and 'brake' options and prize display are all included. There are also two novel features. A car on the central line always means 'no prize' — cars cost money! Furthermore, the 'score' at the top of the screen shows the total gain or loss (nearly always the latter ...).



The program is quite interesting, but also highly complicated. For those who feel like exercising their disassembling skills, data is included from 09DE to 09FF, 0B10 to 0B1F, 0C00 to 0D12 and 0FF6 to 0FFF. The odd unused byte is set to 00.

File 9: Surround

The object of this game is to 'box in' the opponent. A point is lost when a player collides with the background,

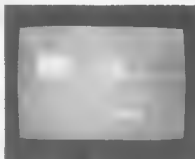


his opponent or even himself. Since the objects move at quite a speed, fast reactions are required to win!

File A: Shapes

This has proved quite popular with the younger generation... Twenty-five

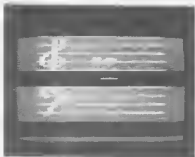
different shapes appear in the 'garage', and then move out to the right. The object is to guess what they represent.



We won't spoil your fun by telling you! The data for the shapes is stored in ten-byte groups from 0A00 on.

File B: Piano

Any desired melody can be keyed in, provided it fits in a two-octave range.



When played back, the corresponding notes are displayed in step with the tune.

File C: PVI programming

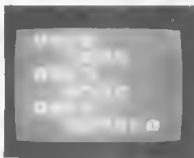
This is a rather complicated program, intended as an aid when developing your own games. It provides the possibility of programming objects and background shapes on the screen, so that the results can be judged more easily. A 'relative address' calculation routine is also included.



This program has proved extremely useful in practice — once you get used to operating the keys!

File D: Disassembler

The object here is quite simple: to make the decoding of an existing program much less laborious! The program to be examined is split up into one-, two- or three-byte instructions, and displayed accordingly.



It should be noted that this program is stored from 08C0 to 08F6 and from 1F80 to 1FAD — it took quite a bit of fiddling to include these two separate program sections as a single File on the tape!

File E: Test patterns

This is exactly what its name implies: a whole series of test patterns for a



(colour) TV set. As such, it has proved extremely useful on numerous occasions...

File F: Lotto

This is intended primarily for our readers in Germany. There, a game is played on the national TV networks that is similar to Bingo. You fill in six random numbers from 1 to 49 on a card, and send it in. At the end of the week, six numbers are 'drawn' in



deathly silence — with umpteen million viewers holding their breath... If your numbers come up, you win. The only mental work involved is in trying to think up six numbers every week. The obvious way to avoid this is to get your home computer to do the job for you...

So much for the games. Now there is one minor point that has come up quite frequently in readers' letters: random numbers. In a previous article, we mentioned that we were thinking of adding a hardware random number generator as part of an extension board. Several readers have pointed out that you can use a software routine for this. True enough; a routine is in fact included in the 'Jackpot' program, from address 0939 to 095C; it generates a random number at address 093A. However, this has one disadvantage in some applications: the number is only random because it depends on the exact moment in time when you operate a key. If a random number were required at regular intervals in a program, this system could not be used: the random number generator would run in synchronism with the program, since it runs off the same clock! This is the main reason why we were — and still are — thinking of adding a simple hardware version. **M**



Britain's first computer kit.

The Sinclair ZX80.

£79.95

Price breakdown
ZX80 and manual £69.52
VAT* £10.43
Post and packing FREE

sinclair
ZX80

Please note many kit makers quote VAT-exclusive prices

You've seen the reviews you've heard the excitement now make it the kit!

This is the ZX80 'Personal Computer World' gave it 5 stars for 'excellent value' Benchmark tests say it's faster than all previous personal computers. And the response from kit and hobbyists has been tremendous.

To help you appreciate its value, the price is shown above with and without VAT. This is so you can compare the ZX80 with competitive kits that don't appear with inclusive prices.

'Excellent value' indeed!

For just £79.95 (including VAT and p&p) you get everything you need to build a personal computer at home. PCB, with IC sockets for all ICs; case, leads for direct connection to a cassette recorder and television (black and white or colour), everything!

Yet the ZX80 really is a complete, powerful, full-featured computer, matching or surpassing other personal computers at several times the price.

The ZX80 is programmed in BASIC, the world's most popular computer language for beginners and experts alike.

The ZX80 is pleasantly straightforward to assemble, using a fine-tipped soldering iron. It immediately proves what a good job you've done: connect it to your TV link it to an appropriate power source and you're ready to go.

Your ZX80 kit contains...

- Printed circuit board, with IC sockets for all ICs
 - Complete component set, including all ICs - all manufactured by selected world-leading suppliers
 - New rugged Sinclair keyboard, touch-sensitive, wipe-clean
 - Ready-moulded case
 - Leads and plugs for connection to domestic TV and cassette recorder (Programs can be SAVED and LOADED on to a portable cassette recorder)
 - FREE course in BASIC programming and user manual
- ### Optional extras
- Memory adaptor of 600 mA at 9 VDC nominal unregulated (available separately - see coupon)
 - Additional memory expansion boards allowing up to 16K bytes RAM (Extra RAM chips also available - see coupon)

*Use a 600 mA at 9 VDC nominal unregulated mains adaptor. Available from Sinclair if desired (see coupon)

The unique and valuable components of the Sinclair ZX80.

The Sinclair ZX80 is not just another personal computer. Quite apart from its exceptionally low price, the ZX80 has two uniquely advanced components: the Sinclair BASIC interpreter, and the Sinclair teach-yourself BASIC manual.

The unique Sinclair BASIC interpreter offers remarkable programming advantages:

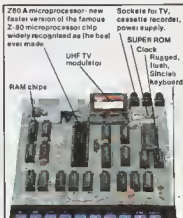
- **Unique 'one-touch' key word entry:** The ZX80 minimal as a great deal of time some typing. Key words (RUN, PRINT, LIST, etc.) have their own single-key entry.
- **Unique syntax check:** Only lines with correct syntax are accepted into programs. A cursor identifies errors immediately. This prevents entry of long and complicated programs with faults only discovered when you try to run them.
- **Excellent string-handling capability:** Takes up to 26 string variables of any length. All strings can undergo all relational tests (e.g. comparison). The ZX80 also has string input request a line of text when necessary. Strings do not need to be dimensioned.
- **Up to 26 single dimension arrays**
- **FOR/NEXT loops nested up to 26**
- **Variable names of any length!**
- **BASIC language also handles full Boolean arithmetic, conditional expressions, etc**
- **Exceptionally powerful edit facilities:** allows modification of existing program lines
- **Randomise function,** useful for games and secret codes, as well as more serious applications
- **Timer under program control**
- **PEEK and POKE enable entry of machine code instructions, USR causes jump to a user's machine language sub-routine**
- **High-resolution graphics with 22 standard graphic symbols**
- **All characters printable in reverse under program control**
- **Lines of unlimited length**

Fewer chips, compact design, volume production - more power per pound!

The ZX80 owes its remarkable low price to its remarkable design: the whole system is packed on to fewer, newer, more powerful and advanced LSI chips. A single SUPER ROM for instance, contains the BASIC interpreter, the character set, operating system, and monitor. And the ZX80's 1K byte RAM is roughly equivalent to 4K bytes in a conventional computer - typically storing 100 lines of BASIC (Key words occupy only a single byte.)

The display shows 32 characters by 24 lines. And Benchmark tests show that the ZX80 is faster than all other personal computers.

No other personal computer offers this unique combination of high capability and low price.



complete



The Sinclair teach-yourself BASIC manual.

It's the specifications of the Sinclair ZX80 mean little to you - don't worry. They're all explained in the specially-written 128-page book free with every kit! The book makes learning easy, exciting and enjoyable... and represents a complete course in BASIC programming - from first principles to complex programs. (Available separately - purchase price refunded if you buy a ZX80 later.) A hardware manual is also included with every kit.

The Sinclair ZX80. Kit: £79.95. Assembled: £99.95. Complete!

The ZX80 kit costs a mere £79.95. Can't wait to have a ZX80 up and running? No problem! It's also available, ready assembled and complete with mains adaptor, for only £99.95.

Demand for the ZX80 is very high - use the coupon to order today for the earliest possible delivery. All orders will be despatched in strict rotation. We'll acknowledge each order by return, and tell you exactly when your ZX80 will be delivered. If you choose not to wait, you can cancel your order immediately and your money will be refunded at once. Again, of course, you may return your ZX80 as received within 14 days for a full refund. We want you to be satisfied beyond all doubt - and we have no doubt that you will be.

sinclair ZX80

Science of Cambridge Ltd

6 Kings Parade, Cambridge, Cambs., CB2 1SN
Tel: 0223 311486

ORDER FORM		To: Science of Cambridge Ltd, 6 Kings Parade, Cambridge, Cambs., CB2 1SN. Remember: all prices shown include VAT, postage and packing. No hidden extras. Please send me	
Quantity	Item	Item price £	Total £
	Sinclair ZX80 Personal Computer (kit) (Price includes ZX80 BASIC manual - excludes mains adaptor)	£79.95	
	Ready-assembled Sinclair ZX80 Personal Computer (Price includes ZX80 BASIC manual and mains adaptor)	£99.95	
	Mains Adaptor(s) (500 mA at 9 V DC nominal unregulated)	8.95	
	Memory Expansion Board(s) (each one takes up to 3K bytes)	12.00	
	RAM Memory chips - standard 1K bytes capacity	16.00	
	Sinclair ZX80 Manuals (manual free with every ZX80 kit or ready-made computer)	5.00	
NB: Your Sinclair ZX80 may qualify as a business expense			TOTAL £
I enclose a cheque/postal order payable to Science of Cambridge Ltd for £			
Please print			
Name: Mr/Mrs/Miss _____			
Address: _____			
			E 10 80

accessed only on pages 00...1F (of which the external pages 04...17 are addressable with signals K1...K5).

Moving the vectors

The NMI, RES and IRO vectors are located in page FF (at addresses FFFA...FFFF). In actual fact in the standard situation the vectors are in page 1F (EPROM IC2). When the circuit given in figure 1 is incorporated, the 6502 will search page FF when an NMI, IRO or reset occur. In other words it will look in vain for IC2. This can be remedied with the aid of figure

2

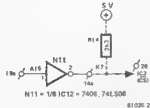


Figure 2. The hardware required to keep vectors NMI, RES and IRQ on page 1F. Figure 4 gives a better, though not always necessary, alternative.

3

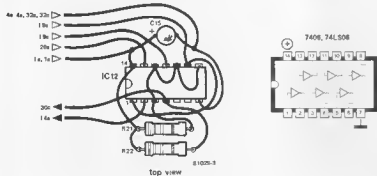
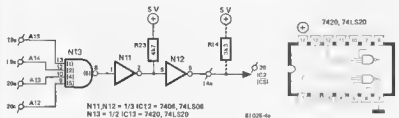


Figure 3. Practical applications for the circuits in figures 1 and 2. A printed circuit board including the decoding hardware as shown in figures 1 and 4 is to be published in due course.

4a



b



Figure 4. An alternative for figure 2 (two hardware possibilities) which provides further options with regard to the maximum amount of external memory. Only the EPROM address block including page FF is not to be used to avoid double addressing (see the article in the Elektor September issue).

2's circuit. As soon as address line A15 is a logic 1 (for instance when addressing page FF), K7 will become a 0 and the IC2 EPROM on the computer main board will be selected.

The solution in figure 2 however has the drawback that a considerable amount of memory is lost. The fact is that any external possibilities with A15=1 (which is 32K of memory) are out of the question. Apart from the standard 8K which is already there, memory extension is only possible on the 96 pages 20...7F. This extension constitutes the 24K available when the memory is absolutely full.

Alternatively, either of the two circuits in figure 4 may be used instead of figure 2 if the full added capability is required. Here K7 will only be zero when the lines A12...A15 are 1. This gives free access to pages 20...EF (a total of 208 pages), amounting to 52K which is enough for another 2 or 3 memory cards.

As already mentioned use of the last 16 pages from F000 to FFFF is limited by the fact that the interrupt Vectors are stored in FFFA...FFFF. Depending on the type of EPROM used, this leads to a greater or smaller limitation. With the 2708, 1K (F000...FFFF) is lost. With the larger 2716, 2K (F800...FFFF) whereas the whole of the last section (F000...FFFF) cannot be used in the 2732.

The drawing in figure 3 shows how the additional hardware (figures 1 and 2) can be built on a temporary basis. "Temporary" means until a circuit board for the hardware extension is published in the Junior Computer Book 3.

missing link

8K RAM card

September 1980, p. 9-04. When using EPROMs type 2732 on this card, the wiring is slightly different to that suggested in the text. Not only must the desired outputs from IC5 be connected to points k, l, m and n, they must also be connected to the inputs of N11. Since the latter only has two inputs, a four-input AND gate must be made with diodes: 1k pull-up resistors are inserted in the spaces provided between connections V and W and the corresponding '4', and two diodes are then connected from each of these points to two of the desired outputs of IC5 (the anodes of the diodes are connected to V or W).

It was also mentioned in the text that 'unused outputs must be connected either to +5V or to an unused output from IC5'. The latter is wrong: they should be connected to +5V only.

remote control slide projector

ultrasonic projector control



Readers who give slide shows regularly will know from bitter experience that the success or failure of the performance can depend on the connecting cables. Although the use of remote control (and its attendant cable) can lead to a much smoother presentation, feet and cables unfortunately do not co-operate very well (particularly in the dark) and can 'stop the show' rather abruptly. An ultrasonic system will therefore add considerably to the advantages of a remote control slide projector by removing the major disadvantage.

The following equation sums up the main problems normally associated with the presentation of slide shows. Feet (guests x 2 and sometimes 4) x number of cables + darkness = ever present and imminent disaster.

There are additional factors of course.

- a) The feet can be very young and therefore far more active. Furthermore, the complete package comes equipped with hands (also active).
- b) Our four-legged friends carry an arsenal of teeth around with them (try buying tooth-proof cable).
- c) The telephone interrupt. 'I'll get it...'

This may all sound 'tongue in cheek' but the fun will really end when the projector leaves its temporary resting place and heads towards a permanent one on the end of a fast-moving cable. The answer is therefore to get rid of the wires and everyone, including the presenter, can get down to enjoy the show.

Four functions

Most modern slide projectors now have a remote control facility. This normally caters for four functions: slide forwards and backwards, focus lens forwards or backwards. It therefore follows that any remote control circuit will have to be able to issue four commands, each at a different time. Simultaneous instructions would be very confusing both for the slide projector and the viewers.

Should our remote control system meet any other requirements? It should, of course, be possible to hold the transmitter section in the hand, in other words, it must be small. It is obvious that it must derive its power from a battery, otherwise wires will have to be brought back into the picture. Current consumption must be as low as possible for the same reason.

As far as the receiver is concerned, we need not worry. It can of course be connected to the mains together with the projector. There is also no need for it to be small.

Ultrasonic

A word that has come up in Elektor time and again. There are various ways in which to transfer commands without the use of wires.

Radio transmission is out because it is illegal. Transferring commands with the aid of infrared light requires a lot of transmission power, so that this possibility must also be excluded. A third possibility remains as the only reasonable one: ultrasonic (sound above human hearing).

To avoid any complications brought about by the doppler effect (variation in the frequency at the receiver end when the transmitter and receiver move with respect to each other) and by differences in signal strength on the part of the receiver, a special form of frequency modulation has been chosen. It is

1

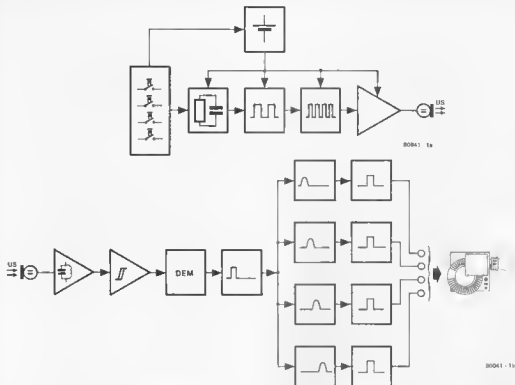


Figure 1. The remote slide control block diagram. Figure 1a shows the ultrasonic transmitter (operation section) and figure 1b the receiver which may be included in or near the slide projector.

possible to increase the 'suitable' frequency modulations in the transmitter, making them much greater than the variations which might well be caused by the doppler effect. Especially if the transmitter frequency does not vary constantly but only has one of two discrete values, which is the case here. If there aren't any commands to be transferred, the transmitter will remain silent and this also helps keep energy consumption at a minimum. Such frequency modulation with two discrete frequencies is called frequency shift keying (FSK).

Block diagram

Both the transmitter and the receiver of the ultrasonic remote slide control are shown in the form of a block diagram in figure 1. Figure 1a illustrates the transmitter section and figure 1b the receiver which can be incorporated in the projector.

The control section includes four pushbuttons, one for each command. Operating one of these pushbuttons changes the RC network, and therefore the frequency, of an astable multivibrator (square wave generator). Its output is connected to the modulation input of a second square wave generator generating the carrier wave for the ultrasonic signal. The carrier wave will thus be modulated by the control frequency.

How often this takes place per second depends on which of the buttons is

pressed.

The carrier wave is amplified and then fed to an ultrasonic transducer which converts the electrical signal into an acoustic one. A similar transducer in the receiver (figure 1b) converts the acoustic signal back to electronics again. A selective amplifier (indicated with an IC loop) considerably amplifies and then limits the signal so that any variations in amplitude do not have an adverse effect on the rest of the circuit. This signal is then demodulated to produce the low frequency signal which contains all the information concerning the transferred commands. A monostable multivibrator shapes the low frequency signal into a series of equal length pulses. Their repetition frequency will now determine the command. Four frequency-dependent circuits (drawn here as band

pass filters) check whether the repetition frequency corresponds to their resonance frequency. If it does, a monostable multivibrator generates a pulse to operate the slide projector.

The transmitter circuit

Figure 2 shows the circuit diagram of the transmitter section of the remote control slide system, in other words the contents of the hand held unit.

The transmitter has to cope with a particular problem in this case, physical size. It must be small enough to fit in the palm of the hand.

For this reason small ICs are used. IC1 is a small voltage regulator, IC2 is a fourteen pin CMOS IC and IC3 is the well known timer 555 in an eight pin DIL case.

S1...S4 are the four pushbuttons. They are all double pole switches, so that digitasts may be used. The 'a' sections of the four pushbuttons act as a supply switch. This means the circuit is only fed with supply voltage when a command is given, thereby resulting in a considerable battery saving.

Use is made of the CMOS IC 4047 to generate the low frequency square waves. This IC is only partly used here. The astable multivibrator (AMV) is the other square wave generator. Its frequency is dependent on which of the pushbuttons is depressed, as they alter the resistance of the RC network. C3 is the capacitor in this network. The astable multivibrator is followed by a



Photo 1. This is what a typical transducer looks like. Note that two different types are used in the transmitter end and the receiver.

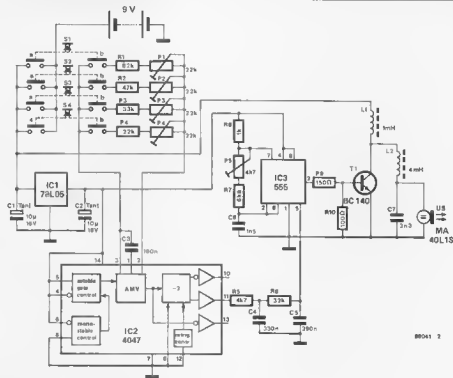


Figure 2. A more detailed view of the transmitter. The circuit has been designed to be as small as possible.

frequency divider which produces a symmetrical square wave of half the frequency.

By way of a low pass filter this square wave reaches the modulation input of IC3, the 555. This IC acts as the modulator for the transmitter. A square wave at its modulation input will frequency modulate. The output signal is amplified with the aid of T1 and then fed to the transducer.

The chokes L1 and L2 enable a fairly large alternating voltage to be available across the transducer, exceeding the supply voltage at both thresholds. This is why T1 receives its supply voltage directly from the battery and not from the 5 V voltage stabilised by IC1. In this manner the transducer can produce a reasonably high acoustic power, and that means another gain in the remote slide control's range and reliability.

The transmitter section circuit contains five preset potentiometers. How these are set will be discussed later.

The receiver circuit

As shown in figure 3, the final circuit for the receiver section of the remote slide control is a little more elaborate than that of the transmitter. This does not present a problem in size since it can be fitted in any convenient case and then placed inside or next to the slide projector.

The ultrasonic signal is received by the ultrasonic transducer. Note that this is a different type from the one in the

transmitter.

The transducer signal is amplified by the circuit around T1. Due to L1 and C2 this amplifier is frequency selective. Op-amps A1 and A2 further amplify the signal which is then passed to the demodulator. This consists of the circuit around A3 and produces the low frequency command signal. The test point TP1 is included at the output of A3 for setting-up purposes and will be explained later.

The op-amp A4 amplifies the low frequency signal and the CMOS schmitt trigger N1 is used to produce a clean symmetrical square wave. N2 together with C14 and R23 form a simple monoflop. It generates a brief pulse for every positive going edge of the command signal waveform.

Digital filters

The output of N4 is fed to four digital filters. One of these is shown in a simplified form in figure 4a. It consists of two monostable multivibrators (or monoflops) MFA and MFB, and an AND gate. The pulse diagram drawn in figure 4b illustrates its operation. At the negative going edge of the input pulses, monoflop MFA is triggered. The negative going edge of its O output (\bar{Q}_A) triggers monoflop MFB. Signals \bar{Q}_A , \bar{Q}_B and the input signal are combined in an AND gate. This 'window' filter will allow pulses to pass, when the input repetition frequency is within the limits of the 'resonant' frequency of the filter. If the

input pulses are too close together (frequency too high) MFA will be continually triggered, MFB will never be triggered and the output signal will remain low. If the input pulses occur at longer intervals (frequency too low), \bar{Q}_A and \bar{Q}_B will have passed before the arrival of the next pulse. Then the output will again be low. Another way of putting it would be to say that every input pulse will keep the gate open for a T_B period (pulse time of MFB) after time T_A (the pulse time of MFA) has passed. The next input pulse will have to arrive during time T_B or it will not get through the gate.

One great advantage of the digital filter is that it is not a real resonance filter, so that it will not only operate well for one specific frequency, but for a whole frequency range within certain thresholds. The frequency curve of a digital filter — if it can be said to have one — has a clearly defined width, is flat in the pass range and (theoretically) has infinitely steep edges.

Figure 3 illustrates the purpose of the digital filters. FF1 corresponds to MFA from figure 4a, and FF2 to MFB. The structure of the other three filters is similar. The 'resonant' frequencies depend on the values of the RC networks that are added. The AND gate is made up of three diodes. The output of each digital filter triggers a monostable multivibrator (FF9... FF12 respectively). These generate the final output pulses which, via schmitt triggers

3

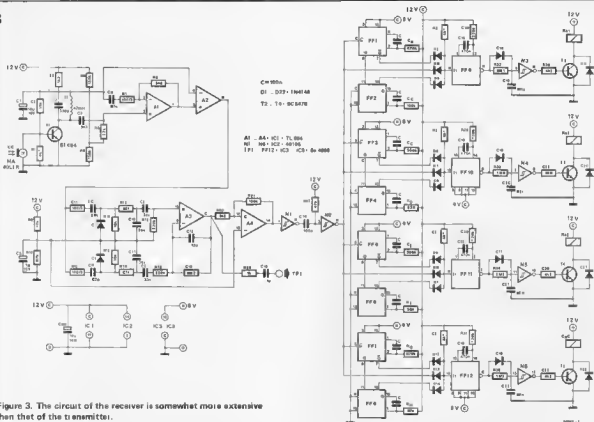


Figure 3. The circuit of the receiver is somewhat more extensive than that of the transmitter.

N3...N6 and transistors T2...T5, will switch the relay. Relays are used as an electro-mechanical solution to cover a wide range of applications. This is because projectors of different makes vary considerably with respect to current switching for slide transfer. In addition, the current may have rather high peaks (up to 2A).

Supply and regulation

The receiver circuit may be supplied from the slide projector's transformer. This is calculated to be between 5 and 12 amps, approximately, so a few extra mA won't be too much of a burden. Fortunately, almost every automatic slide projector is provided with a 24 V transformer. In order to derive the required 12 V direct voltage from this, the circuit in figure 3 may be used.

Unexpectedly perhaps, the remote slide control is set up by ear. The signal at test point TP1 in the receiver circuit is made audible. This can be done by connecting headphones to it (their impedance will need to be at least 200 ohms; if required, a resistor may be switched in series), or the signal may be fed to an amplifier. The resistance of P4 is now increased to a maximum and key S4 is depressed. A fairly low note will be heard (about 75 Hz). P5 must now be adjusted until reception of that note is as clear as possible, even if the transmitter and receiver are both pointing in opposite directions. Now P1 to P4 are adjusted. Above a

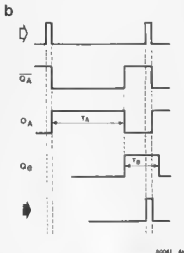
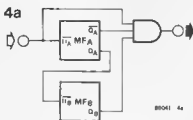


Figure 4. The function of the digital filter, four of them are used in the receiver. Figure 4a gives the circuit diagram and figure 4b the pulse diagram.

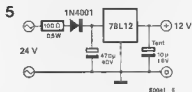


Figure 5. This circuit may be used to supply the receiver circuit from the 24 V transformer.

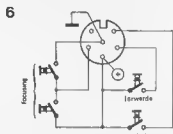


Figure 6. A common connection system in slide projectors. The contacts of the relays in figure 3 will be connected in parallel across the buttons.

certain point in the range of P1, the relay connected to output 1 will be activated. The correct position of P1 will be in the middle of this section. The same procedure applies to presets P2 to P4 with their corresponding relays. After this the setting of P5 is again checked. The circuit will work within a certain range of the preset. Here too the best position is half-way. ■

The original circuit of the video pattern generator (see *Summer Circuits* issue 1979) has been slightly modified and a printed circuit board has been designed for it. The pin numbering of the various gates has been altered, mainly to simplify the layout on the board, and of course the modifications published in *October 1979* have been incorporated. To give a clearer indication of how the unit works, the circuit diagram has been divided into four sections which each carry out a certain function. Block A takes care of the synchronisation pulses. Block B provides the sound output and grey scale circuitry. Block C contains

and a binary counter IC12b. During line and field blanking intervals the oscillator is inhibited and the counter is reset to zero to ensure that each new line is correctly positioned. The outputs of the counter are inverted by N30...N32 to give a descending grey scale. The grey scale is selected by taking the other inputs of these gates high, in other words by operating switch S1.

Pattern generator

The pattern generator (section C) produces eight basic black and white patterns from which a choice can be made with the aid of a rotary switch.

P. Needham

video pattern generator

TV technicians often make use of a video pattern generator to help set up television sets quickly and simply. Pattern generators (normally) produce a video signal which complies with CCIR standards. The video information itself is usually quite simple. The patterns consist of lines, dots and bars, or a combination of them. Design and construction of high quality video pattern generators is not an easy task for the amateur, but if 'reasonable' quality is acceptable there is no need for the TV enthusiast to go without.

the logic required to produce the various patterns and block D comprises the video stage.

Sync generator

The crystal oscillator formed around N3 provides a 1 MHz signal which is divided by IC14 to produce the required 250 kHz input signal. This is then further divided by IC1a to obtain the line frequency (15,625 Hz). The field frequency is produced from the counters IC1b, IC2a and IC2b which twice divide the line frequency (31250 Hz) by 625 to give the required 50 Hz. These counters also control three timers (IC3b, IC4a and IC4b) which, after being triggered by IC3a (the front porch delay), provide the line sync pulse, the field sync pulse and the equalisation pulses. The enable signal for IC3b is also gated with the 12 μ s line blanking pulse (from N4) to ensure correct synchronisation with the line frequency. The flipflop N11/N12 produces the field blanking interval and is reset after every 25 lines. The blanking pulses and the output from the pattern generator are gated by N9 to provide a blanked video drive to the mixer stage.

Sound output

The sound output circuitry consists of little more than a divide-by-sixteen counter, IC12a. This produces a tone of 977 Hz from the line frequency. The amplitude of the output signal is attenuated by R12 and P1 and filtered by C7 to produce a more pleasant sound.

Grey scale

The grey scale is produced by a gated oscillator constructed around N2/N9

Vertical lines

The Q1 output of the grey scale counter (IC12b) is connected to N19 which generates a short output pulse at each transition of the input signal. In this way, fifteen vertical lines are produced.

Horizontal lines

A horizontal line is produced after every 20 TV lines at the output of the flipflop N15/16. The gating on the input ensures that it is one TV line long between the line sync pulses. Fourteen horizontal lines are thus produced.

Crosshatch

For this signal the horizontal and vertical lines are simply ORed together.

Dots

These are produced by ANDing the horizontal and vertical lines together.

Vertical bars

This is the output of the grey scale oscillator (N2 and N29) and gives sixteen vertical bars.

Horizontal bars

The Q3 output of the field counter (IC12a) gives thirteen horizontal bars.

Chessboard

By connecting the horizontal and vertical bar signals to the EXclusive NOR gate N20 a chessboard effect is produced.

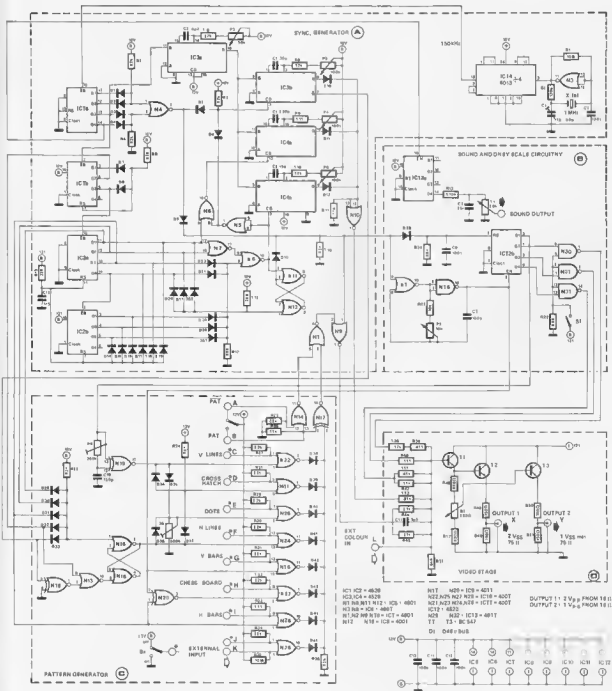


Figure 1. The complete circuit diagram of the video pattern. It is divided into four sections for clarity. A UHF/VHF modulator can be connected directly to the output of the video stage.

External

Provision has been made so that an external pattern signal can be connected to the system via gate N26.

As can be seen, the eight patterns are connected to gates N21...N28. By taking the unused inputs of these gates low the required pattern can be selected.

Gates N14 and N17 allow the choice between 'normal' and 'inverted' patterns. The number of patterns can be extended by selecting several basic patterns together (vertical lines with horizontal bars) or more complex patterns can be produced by utilising the binary outputs of IC12b.

2

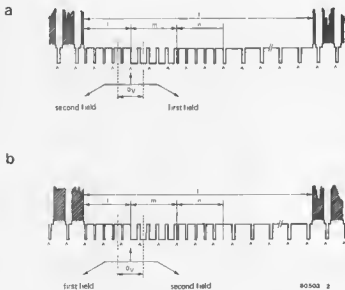


Figure 2. A general idea of what the composite video signal should look like. Figure 2a shows the first field and figure 2b the second.

Parts list:

Resistors:

R1, R35 = 10 M
R2 = 120 k
R3, R4, R5, R7, R11, R13,
R17...R20, R22...R34,
R36 = 22 k
R6, R8, R9, R10,
R38...R42 = 47 k
R12 = 470 k
R37 = 6k8
R43 = 33 k
R44, R45 = 27 k
R46 = 220 Ω
R47 = 330 Ω
R48...R51 = 150 Ω
(R14, R15 and R16 have not been used)

Capacitors:

C1 = 10...60 p
C2, C8, C9 = 100 p
C3 = 8p2

C4 = 330 p
C5 = 33 p
C6 = 15 p
C7 = 15 n
C10 = 150 p
C11 = 3p3
C12 = 1n5
C13...C15 = 100 n

Semiconductors:

T1...T3 = 8C547
D1...D45 = DUS
IC1, IC2, IC12 = 4520
IC3, IC4 = 4528
IC5...IC8, IC10, IC11 = 4001
IC9 = 4077
IC13 = 4011
IC14 = 4013

Miscellaneous:

S1 = single pole switch
S2, S10 = single pole toggle switch

Video stage

In section D the digital input signals are mixed together by the resistor network R37...R45. The composite video signal is then buffered by T1 which drives transistors T2 and T3 to provide two different output levels. The output of T3 can be adjusted by potentiometer P7. Capacitor C11 has been added to improve picture stability. The output from the mixer can be fed to a suitable UHF TV modulator (see Elektor 42, October 1978).

The complete video waveform is shown in figure 2 and figure 3 gives the printed circuit board and component layout for the pattern generator.

Calibration

Initially, potentiometers P3...P6 are set to their mid position and no patterns are selected. The grey scale is switched on with S1 and S2 is placed in the 'invert' position (PAT). Potentiometer P2 can then be adjusted so that eight grey bars of different intensity appear on the screen. The lightest and darkest bars should be at opposite sides of the picture.

Switch S1 is then turned off and vertical lines selected. Potentiometer P9 is then adjusted to give 15 narrow, black, vertical lines on the screen. Dots are then selected and P8 adjusted to give 15 columns.

The CCIR standard can be approached by using an oscilloscope. Potentiometers P3, P4, P5 and P6 control the front porch delay, the field sync, the line sync and the equalisation pulses respectively. The front porch delay should last 1.5 μs, the field sync pulse should last 27.3 μs, the line sync pulse should be 4.7 μs wide and the equalisation pulses should be about 2.35 μs wide.

In some cases the line and field sync pulses can be brought onto the TV screen by switching on the grey scale, switching S2 to 'normal' (PAT) and selecting horizontal lines. The width of the line sync pulse appearing vertically in the picture can be adjusted by P5 until it amounts to 40% of the width of the grey blanking pulse. Potentiometer P3 should then be adjusted until the start of the line sync pulse is about 12.5% away from the left edge of the blanking pulse. The thickening on the horizontal field sync pulse is due to the equalisation pulses. These are adjusted by P6 until they are half the width of the line sync pulse. Finally, the field sync pulse can be adjusted by P4 so that the width of the gap in the beam is equal to the width of the line sync pulse.

The pattern generator produces interlaced pictures only. By removing D19 the interlacing disappears. The representation of an even or uneven field depends on random switch-on phenomena. This may be noticed by the occurrence of half lines in the horizontal bar pattern.

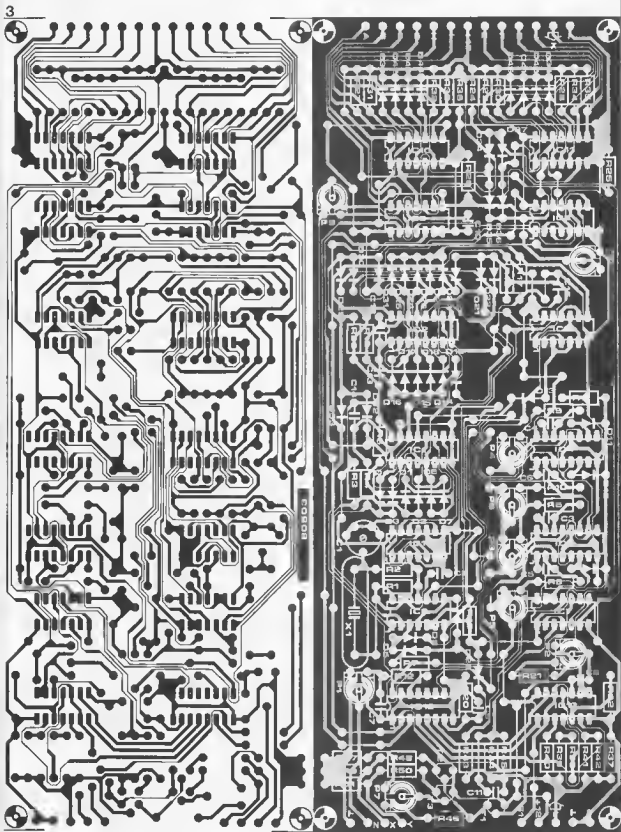


Figure 3. The printed circuit board and component layout for the video pattern generator.

Tuning scale with LCD

LCD frequency counter

If a tuner is to look at all up to date, it will require a digital tuning scale. Thanks to continuing progress in miniaturisation the reader is now able to add a little luxury to his receiver with a minimum of components and at a very low cost. A single IC, one crystal and a liquid crystal display is just about all that is needed. Other advantages of this circuit include high input sensitivity and low current consumption.

A few years ago, building a digital tuning scale required printed circuit boards riddled with ICs. Modern semiconductor technology has brought everything down to size — to a single IC in fact. The SDA5680A recently produced by Siemens includes everything needed to replace the mechanical tuning scale of a receiver with a five figure digital readout.

By using a liquid crystal display (FAN5132T) current consumption is reduced to such an extent that it is even possible to build it into a portable receiver. The only snag is that the choice of MW stations is limited.

The circuit

The complete circuit diagram given in figure 1 shows that apart from the IC and the display, very few components are required. There is no need to worry about the LCD control. The display is connected directly to outputs 12...28 of the counter. For a minimum of connections and a maximum output, three step multiplexing (as described in the 'LCDisplay' article published in

Elektor, May 1980) is used. The potentiometer P1 presets the nominal threshold value of the multiplex voltage. This allows the brightness to be evenly distributed throughout the display.

The frequency counter has three inputs. Pin 2 is the FM oscillator input, pin 4 is the long, medium and short wave oscillator input and pin 5 is an added input for the second IF of double-superhet receivers.

Switch S1 enables the frequency range of the display to be chosen. In principle, this is done by selecting one of the oscillator inputs with S1b. The other part of the switch, S1a, simultaneously presets the right IF for each range.

Table 1 indicates the voltage required for point A (for FM) and for point B (for AM) respectively. Another control input (pin 7) enables the circuit to be preset to 'single-super' or 'double-super'. If points e and f are linked (single-super), the IF is derived from the AM oscillator frequency to obtain the transmitter frequency. If this connection is not made (double-super), the fixed oscillator frequency (multi-conversion input) is derived from the AM oscillator frequency and the IF is added to it.

The frequency counter's time base uses a 4 MHz crystal. This narrows the reading's accuracy down to about 10 kHz on FM and 1 kHz on the other ranges. The quality of the supply need

not be exceptional, however it is important that the supply voltage must never exceed 6 V. A voltage regulator (IC2) maintains the voltage at +5 V. The entire circuit's current consumption is around 30 mA, so that the whole system can be supplied from the receiver itself. If this voltage is less than 8 V, it is advisable to replace IC2 by a zener diode and a resistor.

Construction

The entire circuit as shown in figure 1 can be mounted on the printed circuit board illustrated in figure 2a. This consists of three sections: a bezel plate with a cutout to be placed at the front of the display, a mounting plate with connections for the display, and a section for the rest of the components. Depending on how much space is available. The printed circuit can be used in two different ways — by sawing off the rear section or leaving it as it is.

The LCD must be treated with care. It has no soldering pins and may therefore not be soldered. Contact between the display and the printed circuit board is achieved by a strip of conductive rubber. For proper contact the connections on the printed circuit board will have to be tinned.

Figure 2b shows how the display is mounted. Once the tracks on the rear plate are tinned, the display and the conductive strip can be placed on it. It is a good idea to place another rubber strip (rubber band) on the bottom edge of the display. A rubber ring is placed on the front and then the front plate is mounted (with the aperture cut out). After this the display is tightly screwed between the pressure plates. Not too tightly, however, as this would damage the display. The rubber's elasticity should keep the display in a fixed position.

Connection:

It is possible to couple the digital tuning scale directly to the oscillator circuit of the receiver. This, however, often causes problems — for instance, the oscillator circuit may be mistuned or highly dampened.

The simplest solution is to couple the oscillator inductively by means of a pick-up coil (for FM 1 to 2 turns; for lower frequencies 5 to 20). This is placed near the oscillator, making sure the axis of the coil is parallel to the oscillator coil. Obviously, the letter must not be shielded.

In most FM tuners the pick-up coil can be inserted into the adjustment hole of the oscillator coil screening can. Although there are several coils in a tuner it is quite easy to find out which one belongs to the oscillator. Insert a screwdriver or any other metal object through the adjustment hole of each screening can. The oscillator coil will be the one where most mistuning occurs. The diameter of the pick-up coil should

2a

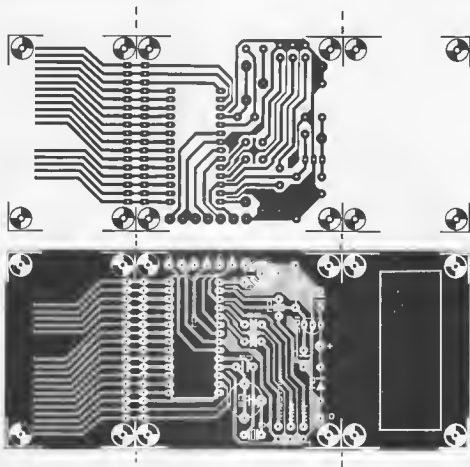


Figure 2a. The copper and component side of the printed circuit board.

Parts list:**Resistors:**

P1 = 250 k preset potentiometer

Capacitors:

C1, C2, C3 = 10 nF

C4, C6 = 100 nF

C5 = 100 μ /10 V

C7 = 3p3

C8 = 10 - 40 pF trimmer

Semiconductors

IC1 = SDA 5680A

IC2 = 78L05

D1 = 1N4001

Miscellaneous:

X1 = 4.0 MHz

Dp = LC-Display

type FAN 5132T

S1 = waferswitch 3 positions,

2 earth contacts

conductive rubber type LZ 302

1 28-pin IC-socket

(All parts available from Doram.)

fiers may be used with various supply voltages when the following values are given to R_A and R_B :

$$R_A = \frac{U_b \cdot 1}{12} \text{ [k } \Omega \text{]} \text{ for FM}$$

$$R_B = \frac{U_b \cdot 1}{6} \text{ [k } \Omega \text{]} \text{ for AM}$$

If the amplifiers are to be connected to the +5 V of the voltage controller on the printed circuit board, R_A will be 330 Ω and R_B 680 Ω .

When everything is functioning properly, the pick-up coils can be permanently fixed with a drop of glue or nail varnish.

Trimming

Trimming is easy - no test equipment will be required. First the light-dark ratio of the display is set at a minimum with P1. Then the quartz oscillator will have to be trimmed. This must be set at a frequency of exactly 4 MHz with the aid of trimmer C8. Since transmission frequencies are very accurate, this can be easily accomplished. Tune to an FM transmitter with a well know frequency and adjust the trimmer until this figure also appears on the display.

Table 2

Package:	28-pin DIL
Supply voltage:	+5 V
Current consumption:	30 mA
Input sensitivity:	150 mV _{eff} 600 kHz < f < 1 MHz
	80 mV _{eff} 1 MHz < f < 2 MHz
	40 mV _{eff} f > 2 MHz
Max. input voltage	1.5 mV _{eff}

Table 2. Technical data of the SDA 5680A.

2b

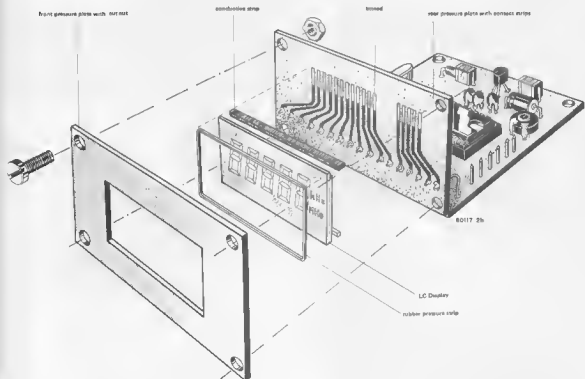


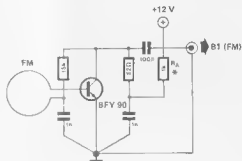
Figure 2b. A drawing showing how to mount the display.

MW programming and screening

In the introduction the fact that the choice of MW stations is limited was mentioned. With FM this will be no problem. 10.7 MHz is the 'normal' IF. As far as the other ranges are concerned, this will be different: 480 kHz \pm 1 kHz is only used by a few German manufacturers. Other receivers work with an IF of 455 kHz producing a display which indicates 5 kHz too little on a single-super and 5 kHz too much on a double-super. As this error goes for the entire AM range, however, it will not present too much of a problem.

Some care should be taken when screening the digital tuning scale. To prevent interference, the circuit is best mounted inside a metal case. **M**

3a



* see text

b

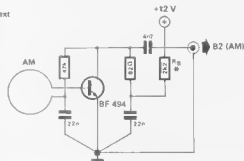
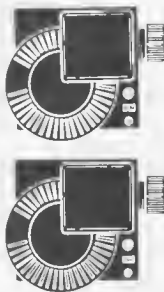
80108.3
80117.2

Figure 3. Two preamplifiers, one for FM and one for AM signals.



dual slide fader III

The circuit for a dual slide fader published in the March 1980 issue of Elektor suffers from one main disadvantage, namely that it will not change slides automatically on projectors with this facility. In this article the dual fader is combined with a control circuit to provide a slide changing on two projectors.

The dual slide fader has proved to be a highly popular circuit both to construct and to use. This article sets out to add a little more sophistication to the original circuit. The purpose of the slide fader is to change the picture on the screen from one projector to the other by simply fading one projector lamp on and the other off. This is carried out by operating a potentiometer. It will be apparent that if a slide is to be changed, it will be on the projector that is not showing a slide, and at a time that the projector lamp is not lit. In other words, when the lamp is turned off — change the slide.

The circuit diagram in figure 1 shows the original slide fader as it was published in March (the low voltage lamp version). It will be useful to briefly recap on the operation of the circuit.

The trigger for the two 555 timer IC's is derived from the mains waveform. Whenever an IC is triggered, the impedance at pin 7 rises and the voltage at pin 3 becomes roughly equal that of the supply. Capacitor C2 (at IC1) will then charge via potentiometer P2a and resistor R2. As soon as the voltage across C2 is higher than 2/3 of the supply voltage, pin 3 becomes

'low' and pin 7 high impedance. C2 then discharges quickly. At the following trigger pulse to pin 2 the cycle will repeat. The waveform at pin 3 will therefore be a pulse train that is synchronised to the mains and this switches the projector lamp by the use of a triac. The duty cycle of the waveform (and therefore the brightness of the projector lamp) is adjustable by P2a. Since P2a and P2b are a dual ganged potentiometer, both circuits are operated simultaneously, but in antiphase. That is, they are wired so that when the resistance of P2a is high, the resistance of P2b will be low. The one control will then regulate the brightness of both projectors — as one projector is being faded on, the other will be fading off.

The slide changer

The circuit diagram for the slide change controller is shown in figure 3. Since the slide must always be changed when the projector light goes out, the level of light in the lamp can be detected. This can be done at the timer output (pin 3). When the average value of the output waveform is at its highest, the lamp will be off.

1

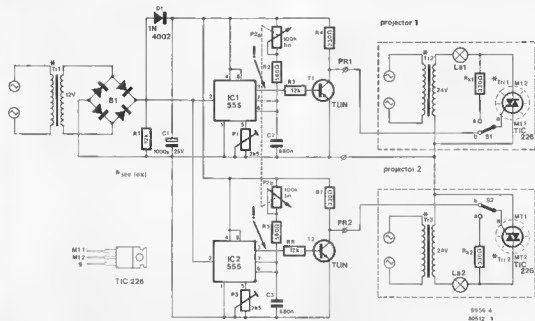


Figure 1. The slide fader as published in Elektor's March 1980 issue.

2

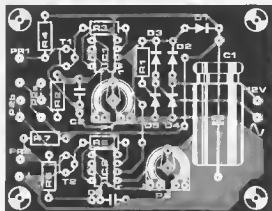
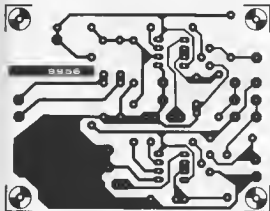


Figure 2. The dual slide fader printed circuit board.

Parts list**Resistors:**

- R1, R7 = 47 k
- R2 = 18 k (see text)
- R3, R6 = 10 k
- R4 = 1 M
- R5 = 100 Ω
- R8 = 39 Ω (see text)
- P1 = 100 k preset potentiometer

Capacitors:

- C1, C2 = 100 μ /25 V

Semiconductors:

- D1, D3 = DUS
- D2 = 5V6/400 mW zenerdiode
- T1 = BC 140
- IC1 = 741

Miscellaneous

- S1 = single pole switch
(if required: S1 + S1 = double pole switch)
- Re1 = relay 1x normally opened
12 V/max 100 mA)

The output at pin 3 is also connected to the non-inverting input of a 741. This waveform is integrated by means of C1, so that a smoothed DC voltage reaches the IC. The dividing factor may be preset with P1. The inverting input of the 741 is connected to a reference voltage which is derived from the supply voltage via P2 and P3. If the input voltage is higher than the reference voltage, the output of the op-amp will be high. The switching point is adjusted by P1 to enable the op-amp's output to be high when a lamp is off. When the 741 output becomes high the relay will be operated by transistor T1 for a short period of time. The relay

market

WORLDWIDE

Solid-state a.c. mains power controllers

A new range of solid-state a.c. mains power controllers for use on loads up to 3000 watts at 240 volts 50/60 Hz has been introduced by United Automation Ltd. Produced in the form of a thick-film silicon chip with maximum dimensions of 49.2 x 15.9 x 6.4 mm, the new controllers offer a 50 : 1 size reduction, as well as considerable savings in cost, when compared with conventional units using discrete components.



The CSR (Controlled Silicon Rectifier) Series 1004 is rated at 10 amps and the CSR Series 1504 at 15 amps. Both types are supplied in a convenient 3-terminal package containing all the components necessary to govern power up to 3000 watts by means of phase-angle control. When fitted with a potentiometer they will control load power smoothly from 0% to 99%. As their firing pattern is symmetrical, they are ideal for controlling transformer outputs as well as mains supplies.

Both 10-amp and 15-amp versions have either small mounting-tabs for riveting or bolting to a heat-sink or chassis, or large tabs for bush mounting on a potentiometer. The 15-amp device can also be supplied ready-fitted with a potentiometer, either in an open form or as a totally-enclosed power controller with an integral heat-sink.

United Automation Ltd.,
237a Liverpool Road,
Birkdale, Southport,
Merseyside PR8 4PF, England,
Telephone: Southport (0704) 65713

(1630 M)

The answer to low-cost EPROM-erasing

Fast and efficient erasure of EPROMs is provided by these low-cost ultraviolet erasers, manufactured by the Spectronics Corporation of the United States and now available in the UK from Chiptech Limited.

They have been designed primarily for the small systems and computer hobbyist at a cost which is well within their reach.

For as little as £56.00, the customer can purchase from stock an ultraviolet eraser - model PE-14 - with the capacity to completely erase up to 8 EPROM chips at one time, in as little as 19 minutes. Rated life of the high intensity UV tubes used is 600 hours. A similarly rated unit, model PE-14T, is fitted with a 60-minute timer automatically shut off the unit and costs £76.58.



All erasers are fitted with safety interlocks and housed in gold-enodised aluminium casings which combine to make them extremely safe. Other more powerful, faster erasing versions of the PE-14 series are also available. The PE-24T will erase up to 9 EPROM chips at one time in as little as 15 minutes. The lamp's double-tube construction provides broader and more intense ultraviolet distribution, making it more suitable for larger systems users and data processing centres. Automatic unit shut-off with a 60-minute timer is again provided. Cost of model PE-24T is £111.22.

Chiptech Limited,
Unit One,
Tewin Court,
Walwyn Garden City,
Hertfordshire AL7 1AU,
Telephone: 07073 33266.

(1634 M)

Sub-miniature relay

Designated the Type GZ, this sub-miniature relay incorporates two double-pole, double-throw contacts. The standard relay contains gold over silver-nickel alloy contacts with a switching capability of 3 A at 30 V d.c. or 120 V a.c., resistive. For heavy-duty operation of up to 5 A at 30 V d.c. or 120 V a.c., resistive, gold over silver-nickel alloy contacts are used; and for low-power requirements, gold over silver-palladium bifurcated contacts provide a 1 A at 30 V d.c. or 120 V a.c. switching capability. Other operational characteristics include coil voltages of 6, 12, 24 and 48 V d.c., power



consumption of 0.65 W, minimum operating power of 0.27 W, and an operational temperature range from -30°C to +70°C.

The type GZ sub-miniature relay is designed for direct mounting onto a printed circuit board, and measures 27.9 mm x 18.5 mm

x 22.0 mm when mounted. Optional p.c. terminal arrangements are available, with either 0.3 in. terminal spacings which conform with the industry standard 0.1 in. grid format, or non-standard spacings for applications in which the track requirements are non-conventional or critical.

Diamond H Controls Ltd.,
Vulcan Road North,
Norwich NR6 6AH,
Telephones: Norwich (0603) 45291/9,
Telex: 975163.

(1633 M)

Digital tachometer for use in sunlight

This portable digital tachometer (model 1893), designed for measuring rpm in areas of high ambient light, is made by Power Instruments Inc of the USA and imported exclusively by Electronic Brokers Ltd. The instrument measures rpm instantly at between 1/4" to 30" distance from a rotating object, using a beam of light. A piece of reflective tape is attached to the object, and the beam of the tachometer is pointed towards the reflective material. A 'target eye' lights up showing contact is made, and the speed can be read off on the five 1/2" high LCD's, with a memory button recalling the last reading.

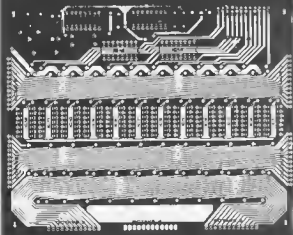


With a quartz controlled accuracy of ± 1 rpm, model 1893 covers a range from 10 - 100,000 rpm, operating from a standard 1.5 V battery and 9 V transistor battery. Overall dimensions are 8 1/2" x 4 1/2" x 2", and the instrument weighs 1 1/2 lbs. It is complete with a carrying case, marking tape and disc set, plus two feet of one inch reflective tape and ten discs. Price is £165, plus VAT and carriage.

Electronic Brokers Ltd,
49/53 Pancras Road,
London NW1 2QB,
Tel: 01-837 7781

(1640 M)

SERVICES TO READERS



EPS print service

Many Elektor circuits are accompanied by printed circuit designs. Some of these designs, but not all, are also available as ready-etched and pre-drilled boards, which can be ordered from any of our offices. A complete list of the available boards is published under the heading 'EPS print service' in every issue. Delivery time is approximately three weeks.

It should be noted however that only boards which have at some time been published in the EPS list are available, the fact that a design for a board is published in a particular article does not necessarily imply that it can be supplied by Elektor.

Technical queries

Please enclose a stamped, self-addressed envelope, readers outside UK please enclose an IRC instead of stamps.

Letters should be addressed to the department concerned — TQE (Technical Queries). Although we feel that this is an essential service to readers, we regret that certain restrictions are necessary

1. Questions that are not related to articles published in Elektor cannot be answered.
2. Questions concerning the connection of Elektor designs to other units (e.g. existing equipment) cannot normally be answered, owing to a lack of practical experience with those other units. An answer can only be based on a comparison of our design specifications with those of the other equipment.
3. Questions about suppliers for components are usually answered on the basis of advertisements, and readers can usually check these themselves.
4. As far as possible, answers will be on standard reply forms.

We trust that our readers will understand the reasons for these restrictions. On the one hand we feel that all technical queries should be answered as quickly and completely as possible; on the other hand this must not lead to overloading of our technical staff as this could lead to blown fuses and reduced quality in future issues.

NEW NICKEL CADMIUM

CELLS		
D Cell 1U2 size 4A/H	£2 20	
C Cell 1U11 size 2A/H	£1 50	
BR Cell 1 2A/H	£1 10	
3C Cell 0 7A/H	£1 00	
AA Cell 0 5A/H	£0 50	

All above cells are vented + suitable for fast charging

BUTTON CELLS

1 2a	
200mA/H 40p	280mA/H 55p
500mA/H 70p	900mA/H £1 05
1 75A/H £1 50	

Ribbon cable 8 way 25p/metre
20 way 60p/metre

HIGH PERFORMANCE POWER SUPPLY KIT

Zener 30v 5mA x 1 SA	
O/P resistance 1mΩ (at board D/P)	
Noise/slope 1mV amp short current limit generally idiosyncratic	
Kit of parts P/G PCB trimmed controls	
more all components	£1 00
Schools/Colleges	£1 00
P & P	85p

Version on 10m ² Ceramic Filters	85p
455K Ceramic Filter	80p
Stereo Cassette Deck Top Loading	50p
(£8 00p)	

Mono Cassette Amp /DSC Board with	
Control	£1 50
LM107 Op Amp sum 741 307	
Uncompensated 30U but no offset null!	

Hum/drv Switch Adjustable	20p
As operated Switch 1/PS1	£1 00 130p
2 Photo Mains Latching Relay £1 00 130p	
Cradle Relay 600U 12v Verley type with base	65p
as above but 12v	75p

READ TRANSISTORS NTC Res at

207 250R 1x2 20k 50k 220k 1mΩ 60p	
-----------------------------------	--

Mini Relay 2p C/O ex caps	50p
GPD Buzzers 12v 50v	50p
PCB with Umc 2W2846	60p

plus 4p C/O 12v relay	
100k 10 Turn Potentiometer ideal	
FM/TV Tuner	80p £20 00p

10 Turn Trimpot 10R 20R 100R	£100 000
200R 500R 2k 5k 20k 22k 50k 40p	
1000pF 10kV Caps Joly available	25p
Sprague 30A RFI Filter	£5 00 180p

SUB MIN BUTTON MICROSWITCH 337 829	50p
FUTABA FLUORESCENT DISPLAY	50p
8 dip 9 CT 01 3L	£1 50
SPRARR 30M ROLL	£1

Headshrink Sleeving	
Assorted 1m lengths	£1 50 135p
250 mixed Resistor	£1 120p
3 1/2 digit LCD Display	£4 125p
4 digit LCD Display	£4 125p

Mono Cassette R/P Head	£1 125p
Cassette Erase Head	50p 112p

Rubber 13A Menneplug	65p 130p
Rubber 13A Ironing S&I	65p 130p
Regulators 78V series	
5v, 12v, 15v, 24v	80p 112p

Convergence Pots 20 assorted	£1 125p
LM324 Quad 741 14 pin DIL 70p 112p	
1458 Dual 741 8 pin DIL	80p 112p

£R0 150v 10%AX 750v	£3 50 00p
£R0 100v 10%AX 100v	£4 00 00p
£R0 10v 10%AX 100v	£2 50 00p
2p 2 C80	£81 00p, £201 00p
1pS MULLARD AX	£7 100

Capacitors	
Sprague 26 000v 30v	£1 80 138p
4700v 25v	80p 125p
4700v 35v	70p 120p
4700v 63v	80p 125p

Paper 1μ 700v — ideal electronic ignition	70p 125p
---	----------

MIN ORDER £2/MIN P&P 35p	
UNIVERSITIES COLLEGES SCHOOLS GOVT DEPARTMENTS WILL REFUND EXCESS P&P	

OFFICIAL ORDERS WELCOME	
SCHOOLS GOVT DEPARTMENTS (P&P SHOWN IN BRACKETS)	

ADD 15% VAT TO TOTAL	
----------------------	--

KEYTRONICS	
------------	--

332 LEY STREET, ILFROUQ, ESSEX	
Shop open Mon. - Sat. 9.30 a.m. - 2 p.m.	
TELEPHONE 553 8863	

DIODES

IN914 Equiv IN4148	£1 50/100
153470 Ge	£1/100
1544	£1 25/150
IN4003 1A 300v	£3/100

BRIDGE RECS

3A 200v	30p
1 5A 200v	25p
2 5A 100v	30p
SCR 800v 10A	50p
TRIAC 800v 8A	85p
TRIAC 400v 4A	60p
SCR 100A 600v	£3
BC107B 1TT	£8/100
BC261 B	£8/100
£S754	£1 00/150
BFY54	£8/100
PBC 106 1TO192	£4/100

1A TOS TRANSISTORS	
5m BFY51 but 25v	£10/100

TESTED 2N3055 ex ant	20p
SCR C106F no Tets 4A 100v	£20 100

2N5777 Photo Darlington	50p
BC238 BC239	£30/100
PCB PINS 1x1 0 1 Varobond	£5/100
	50p/100
	£3/100

WV RESISTORS	
0 11 10v 10w	25p
0 31 1w 10v 25w	35p
T1591 UNLI	30p
2N3886	60p
OC29	50p
NEFL12 Photo Darlington 1base o/c	50p
Photo Diode	25p
KSP 1052 Equiv 2N3440	50p
Light Dependent Resistor	
TO18 case	
LDR RPY58	50p

Zenex 400mW	£4 50/100
2x7 3x3, 3x3 4x7, 5x5 6x2,	£35/1 000
Zenex 1w 1w3	£7/100
5x5 7x8, 8x2 12x 15v, 10v, 27v, 33v 5v	

TO3 Mounting Kit	£2 50/100
TO220 Mounting Kit	£2 10/100

Zenex 400mW	£4 50/100
2x7 3x3, 3x3 4x7, 5x5 6x2,	£35/1 000
Zenex 1w 1w3	£7/100
5x5 7x8, 8x2 12x 15v, 10v, 27v, 33v 5v	

TO3 Mounting Kit	£2 50/100
TO220 Mounting Kit	£2 10/100

Zenex 400mW	£4 50/100
2x7 3x3, 3x3 4x7, 5x5 6x2,	£35/1 000
Zenex 1w 1w3	£7/100
5x5 7x8, 8x2 12x 15v, 10v, 27v, 33v 5v	

TO3 Mounting Kit	£2 50/100
TO220 Mounting Kit	£2 10/100

Zenex 400mW	£4 50/100
2x7 3x3, 3x3 4x7, 5x5 6x2,	£35/1 000
Zenex 1w 1w3	£7/100
5x5 7x8, 8x2 12x 15v, 10v, 27v, 33v 5v	

TO3 Mounting Kit	£2 50/100
TO220 Mounting Kit	£2 10/100

Zenex 400mW	£4 50/100
2x7 3x3, 3x3 4x7, 5x5 6x2,	£35/1 000
Zenex 1w 1w3	£7/100
5x5 7x8, 8x2 12x 15v, 10v, 27v, 33v 5v	

TO3 Mounting Kit	£2 50/100
TO220 Mounting Kit	£2 10/100

Zenex 400mW	£4 50/100
2x7 3x3, 3x3 4x7, 5x5 6x2,	£35/1 000
Zenex 1w 1w3	£7/100
5x5 7x8, 8x2 12x 15v, 10v, 27v, 33v 5v	

TO3 Mounting Kit	£2 50/100
TO220 Mounting Kit	£2 10/100

Zenex 400mW	£4 50/100
2x7 3x3, 3x3 4x7, 5x5 6x2,	£35/1 000
Zenex 1w 1w3	£7/100
5x5 7x8, 8x2 12x 15v, 10v, 27v, 33v 5v	

TO3 Mounting Kit	£2 50/100
TO220 Mounting Kit	£2 10/100

Zenex 400mW	£4 50/100
2x7 3x3, 3x3 4x7, 5x5 6x2,	£35/1 000
Zenex 1w 1w3	£7/100
5x5 7x8, 8x2 12x 15v, 10v, 27v, 33v 5v	

TO3 Mounting Kit	£2 50/100
TO220 Mounting Kit	£2 10/100

Zenex 400mW	£4 50/100
2x7 3x3, 3x3 4x7, 5x5 6x2,	£35/1 000
Zenex 1w 1w3	£7/100
5x5 7x8, 8x2 12x 15v, 10v, 27v, 33v 5v	

TO3 Mounting Kit	£2 50/100
TO220 Mounting Kit	£2 10/100

Zenex 400mW	£4 50/100
2x7 3x3, 3x3 4x7, 5x5 6x2,	£35/1 000
Zenex 1w 1w3	£7/100
5x5 7x8, 8x2 12x 15v, 10v, 27v, 33v 5v	

TO3 Mounting Kit	£2 50/100
TO220 Mounting Kit	£2 10/100

Zenex 400mW	£4 50/100
2x7 3x3, 3x3 4x7, 5x5 6x2,	£35/1 000
Zenex 1w 1w3	£7/100
5x5 7x8, 8x2 12x 15v, 10v, 27v, 33v 5v	

TO3 Mounting Kit	£2 50/100
TO220 Mounting Kit	£2 10/100

Zenex 400mW	£4 50/100
2x7 3x3, 3x3 4x7, 5x5 6x2,	£35/1 000
Zenex 1w 1w3	£7/100
5x5 7x8, 8x2 12x 15v, 10v, 27v, 33v 5v	

TO3 Mounting Kit	£2 50/100
TO220 Mounting Kit	£2 10/100

Zenex 400mW	£4 50/100
2x7 3x3, 3x3 4x7, 5x5 6x2,	£35/1 000
Zenex 1w 1w3	£7/100
5x5 7x8, 8x2 12x 15v, 10v, 27v, 33v 5v	

TO3 Mounting Kit	£2 50/100
TO220 Mounting Kit	£2 10/100

Zenex 400mW	£4 50/100
2x7 3x3, 3x3 4x7, 5x5 6x2,	£35/1 000
Zenex 1w 1w3	£7/100
5x5 7x8, 8x2 12x 15v, 10v, 27v, 33v 5v	

TO3 Mounting Kit	£2 50/100
TO220 Mounting Kit	£2 10/100

ELEKTOR BOOK SERVICE



SC/MPUTER (1) — describes how to build and operate your own microprocessor system — the first book of a series — further books will show how the system may be extended to meet various requirements.

Price — UK £3.70 Overseas £3.90

FORMANT — complete constructional details of the Elektor Formant Synthesiser — comes with a FREE cassette of sounds that the Formant is capable of producing together with advice on how to achieve them.

Price — UK £4.50 Overseas £4.70

300 CIRCUITS for the home constructor — 300 projects ranging from the basic to the very sophisticated.

Price — UK £3.50 Overseas £3.70

DIGIBOOK — provides a simple step-by-step introduction to the basic theory and application of digital electronics and gives clear explanations of the fundamentals of digital circuitry, backed up by experiments designed to reinforce this newly acquired knowledge — supplied with an experimenter's PCB.

Price — UK £5.00 Overseas £5.20

BOOK 75 — a selection of some of the most interesting and popular construction projects that were originally published in Elektor issues 1 to 8.

Price — UK £3.50 Overseas £3.70

When ordering please use the Elektor Readers' Order Card in this issue (the above prices include p. & p.)