

EEV
February 1978
ELEKTOR
up-to-date electronics for lab and leisure

Swinder Singh

U.K. 50 p
U.S.A./CAN. \$ 1.50

**throwing some light
on LEDs**

CMOS function generator

development timer

infra-red light gate

Austria	S. 33
Belgium	F. 55
Denmark	Kr. 9
France	F. 7
Germany	DM. 3.80
Netherlands	DFL. 3.25
Norway	Kr. 9
Sweden	Kr. 9 incl. moms
Switzerland	F. 4.40

elektor 34

Volume 4

Number 2

Editor : W. van der Horst
 Deputy editor : P. Holmes
 Technical editors : J. Barendrecht
 G.H.K. Dam
 E. Krempelsauer
 G.H. Nachbar
 A. Nachtmann
 K.S.M. Walraven
 Subscriptions : Mrs. A. van Meyel

International head offices: Elektuur B.V.
 P.O. Box 75
 Beek (L), Netherlands
 Telex: 56617 Elekt NL

U.K. editorial offices, administration and advertising:
 Elektor Publishers Ltd., Elektor House,
 10 Longport Street, Canterbury CT1 1PE, Kent, U.K.
 Tel.: Canterbury (0227)-54430. Telex: 965504.
 Please make all cheques payable to Elektor Publishers Ltd.
 at the above address.

Bank: 1. Midland Bank Ltd., Canterbury, A/C no. 11014587
 Sorting code 40-16-11, Giro no. 3154254.
 2. U.S.A. only: Bank of America, c/o World Way
 Postal Center, P.O. Box 80689, Los Angeles,
 Cal. 90080, A/C no. 12350-04207.

Assistant Manager and Advertising : R.G. Knapp
 Editorial : T. Emmens

ELEKTOR IS PUBLISHED MONTHLY on the third Friday of each month.

1. U.K. and all countries except the U.S.A. and Canada:
 Cover price £ 0.50.
 Number 39/40 (July/August), is a double issue,
 'Summer Circuits', price £ 1.—.
 Single copies (incl. back issues) are available by post from our
 Canterbury office, at £ 0.60 (surface mail) or £ 0.95 (air mail).
 Subscriptions for 1978, January to December incl.,
 £ 6.75 (surface mail) or £ 12.00 (air mail).
2. For the U.S.A. and Canada:
 Cover price \$ 1.50.
 Number 39/40 (July/August), is a double issue,
 'Summer Circuits', price \$ 3.—.
 Single copies (incl. back issues) \$ 1.50 (surface mail) or
 \$ 2.25 (air mail).
 Subscriptions for 1978, January to December incl.,
 \$ 18.— (surface mail) or \$ 27.— (air mail).
 All prices include post & packing.

CHANGE OF ADDRESS. Please allow at least six weeks for change of address. Include your old address, enclosing, if possible, an address label from a recent issue.

LETTERS SHOULD BE ADDRESSED TO the department concerned:
 TQ = Technical Queries; ADV = Advertisements; SUB = Subscriptions;
 ADM = Administration; ED = Editorial (articles submitted for
 publication etc.); EPS = Elektor printed circuit board service.

For technical queries, please enclose a stamped, addressed envelope or a self-addressed envelope plus an IRC.

THE CIRCUITS PUBLISHED ARE FOR domestic use only. The submission of designs or articles to Elektor implies permission to the publishers to alter and translate the text and design, and to use the contents in other Elektor publications and activities. The publishers cannot guarantee to return any material submitted to them. All drawings, photographs, printed circuit boards and articles published in Elektor are copyright and may not be reproduced or imitated in whole or part without prior written permission of the publishers.

PATENT PROTECTION MAY EXIST in respect of circuits, devices, components etc. described in this magazine.

The publishers do not accept responsibility for failing to identify such patent or other protection.

National **ADVERTISING RATES** for the English-language edition of Elektor and/or international advertising rates for advertising at the same time in the English, Dutch and German issues are available on request.

DISTRIBUTION in U.K.: Spotlight Magazine Distributors Ltd.,
 Spotlight House 1, Bentwell Road, Holloway, London N7 7AX.

DISTRIBUTION in CANADA: Gordon and Gotch (Can.) Ltd.,
 55 York Street, Toronto, Ontario, M5J 1S4.

Copyright © 1978 Elektor publishers Ltd - Canterbury.

Printed in the Netherlands.

decoder

What is a TUN?
 What is 10 n?
 What is the EPS service?
 What is the TQ service?
 What is a missing link?

Semiconductor types

Very often, a large number of equivalent semiconductors exist with different type numbers. For this reason, 'abbreviated' type numbers are used in Elektor wherever possible:

- '741' stand for μ A741, LM741, MC641, MIC741, RM741, SN72741, etc.
- 'TUP' or 'TUN' (Transistor, Universal, PNP or NPN respectively) stand for any low frequency silicon transistor that meets the following specifications:

U _{CEO} , max	20V
I _C , max	100 mA
h _{fe} , min	100
P _{tot} , max	100 mW
f _T , min	100 MHz

Some 'TUN's are: BC107, BC108 and BC109 families; 2N3856A, 2N3859, 2N3860, 2N3904, 2N3947, 2N4124. Some 'TUP's are: BC177 and BC178 families; BC179 family with the possible exception of BC159 and BC179; 2N2412, 2N3251, 2N3906, 2N4126, 2N4291.

- 'DUS' or 'DUG' (Diode Universal, Silicon or Germanium respectively) stands for any diode that meets the following specifications:

	DUS	DUG
U _R , max	25V	20V
I _F , max	100mA	35mA
I _R , max	1 μ A	100 μ A
P _{tot} , max	250mW	250mW
C _D , max	5pF	10pF

Some 'DUS's are: BA127, BA217, BA218, BA221, BA222, BA317, BA318, BAX13 BAY61, 1N914, 1N4148.

Some 'DUG's are: OA85, OA91, OA95, AA116.

- 'BC107B', 'BC237B', 'BC547B' all refer to the same 'family' of almost identical better-quality silicon transistors. In general, any other member of the same family can be used instead.

BC107 (-8, -9) families:

BC107 (-8, -9), BC147 (-8, -9), BC207 (-8, -9), BC237 (-8, -9), BC317 (-8, -9), BC347 (-8, -9), BC547 (-8, -9), BC171 (-2, -3), BC182 (-3, -4), BC382 (-3, -4), BC437 (-8, -9), BC414

BC177 (-8, -9) families:

BC177 (-8, -9), BC157 (-8, -9), BC204 (-5, -6), BC307 (-8, -9), BC320 (-1, -2), PC350 (-1, -2), BC557 (-8, -9), BC251 (-2, -3), BC212 (-3, -4), BC512 (-3, -4), BC261 (-2, -3), BC416.

Resistor and capacitor values

When giving component values, decimal points and large numbers

of zeros are avoided wherever possible. The decimal point is usually replaced by one of the following abbreviations:

p (pico-) = 10^{-12}
 n (nano-) = 10^{-9}
 μ (micro-) = 10^{-6}
 m (milli-) = 10^{-3}
 k (kilo-) = 10^3
 M (mega-) = 10^6
 G (giga-) = 10^9

A few examples:

Resistance value 2k7: 2700 Ω .

Resistance value 470: 470 Ω .

Capacitance value 4p7: 4.7 pF, or 0.000 000 000 004 7 F . . .

Capacitance value 10n: this is the international way of writing 10,000 pF or .01 μ F, since 1 n is 10^{-9} farads or 1000 pF.

Resistors are $\frac{1}{4}$ Watt 5% carbon types, unless otherwise specified.

The DC working voltage of capacitors (other than electrolytics) is normally assumed to be at least 60 V. As a rule of thumb, a safe value is usually approximately twice the DC supply voltage.

Test voltages

The DC test voltages shown are measured with a 20 k Ω /V instrument, unless otherwise specified.

U, not V

The international letter symbol 'U' for voltage is often used instead of the ambiguous 'V'. 'V' is normally reserved for 'volts'. For instance: U_B = 10 V, not V_B = 10 V.

Mains voltages

No mains (power line) voltages are listed in Elektor circuits. It is assumed that our readers know what voltage is standard in their part of the world! Readers in countries that use 60 Hz should note that Elektor circuits are designed for 50 Hz operation. This will not normally be a problem; however, in cases where the mains frequency is used for synchronisation some modification may be required.

Technical services to readers

• **EPS service.** Many Elektor articles include a lay-out for a printed circuit board. Some - but not all - of these boards are available ready-etched and predrilled. The 'EPS print service list' in the current issue always gives a complete list of available boards.

• **Technical queries.** Members of the technical staff are available to answer technical queries (relating to articles published in Elektor) by telephone on Mondays from 14.00 to 16.30. Letters with technical queries should be addressed to: Dept. TQ. Please enclose a stamped, self addressed envelope; readers outside U.K. please enclose an IRC instead of stamps.

• **Missing link.** Any important modifications to, additions to, improvements on or corrections in Elektor circuits are generally listed under the heading 'Missing Link' at the earliest opportunity.

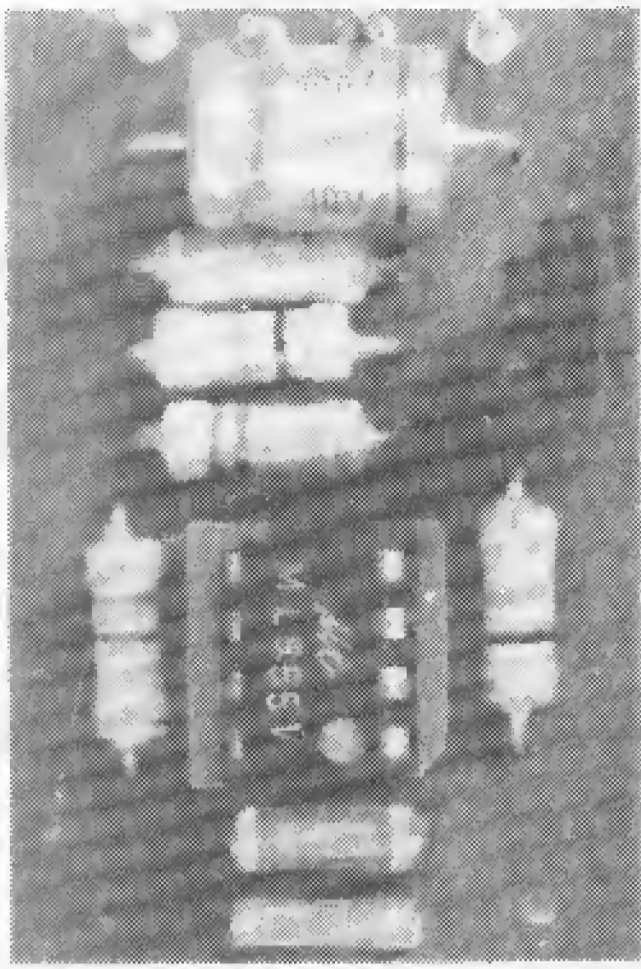

The infra-red light gate can be used in a wide variety of applications ranging from intruder alarms to automatic garage door openers. When the light beam from the infra-red source is interrupted, the receiver circuit detects this and energises a relay.

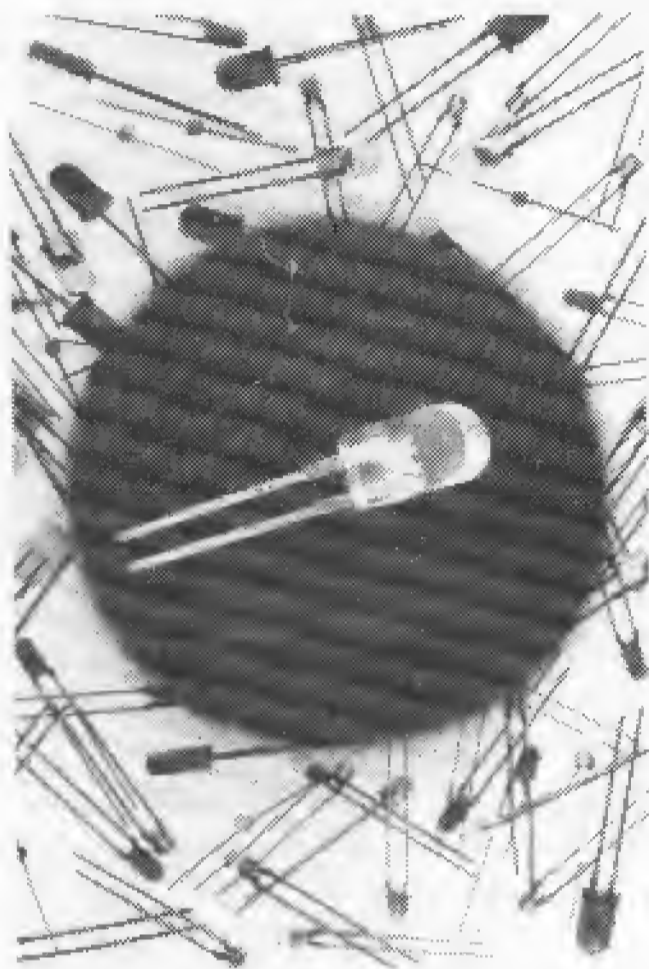

'Throwing some light on LEDs' aims to dispel some of the mystery surrounding LEDs, so that the constructor can choose the most suitable type for his requirements, and calculate the operating conditions.

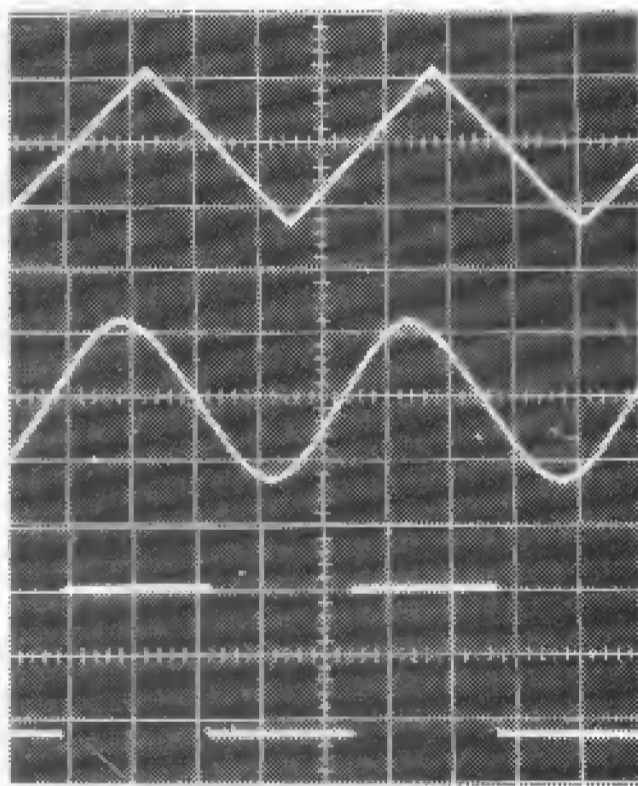

Using only one inexpensive CMOS IC and a handful of discrete components, it is possible to build a versatile CMOS function generator that will provide a choice of three waveforms over the entire audio spectrum and beyond.

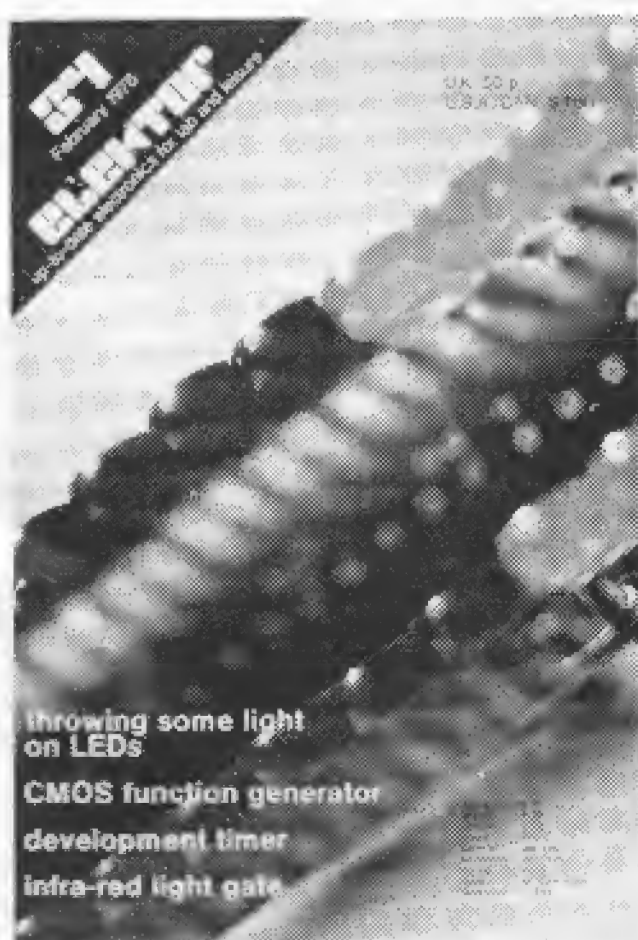

The reason why LED displays are becoming ever more popular is obvious: they look so neat! Quite apart from being reliable and requiring relatively little power.

throwing some light on LEDs
CMOS function generator
development timer
infra-red light gate

contents

selektor	2-01
infra-red light gate	2-02
throwing some light on LEDs	2-06
formant — the elektor music synthesiser (8) ..	2-10
C. Chapman	
This article continues the discussion of the tone-forming circuits with a description of the Dual VCA module, which can be used in conjunction with the envelope shaper for dynamic control of signal amplitude, and also for periodic amplitude modulation of the signal waveform (tremolo).	
slow on/off	2-17
The slow on/off fader circuit will fade the lighting up and down slowly, rather than switching it on and off abruptly.	
CMOS function generator	2-20
zener tester	2-22
This simple tester provides a reliable means of measuring zener voltages and of plotting the variation of zener voltage with zener current.	
development timer	2-24
Developing photographic films can be something of a chore. Not only is it necessary to measure the total development time, but it is also necessary to agitate the development tank at frequent intervals to ensure even development of the film. This means that the clock must be watched continuously. The development timer described in this article overcomes these problems by measuring the intervals at which and the length of time for which the tank must be agitated, as well as the total development time.	
experimenting with the SC/MP (4)	2-28
H. Kampschulte, H. Huschitt	
By abolishing the restriction of having to work exclusively in binary code, the hexadecimal input/output unit described in this article considerably increases the ease and speed with which the user can communicate with the SC/MP — providing, of course, that he has a thorough grasp of the relevant software.	
market	2-39
advertiser's index	E-16



Conference on microprocessors

The advent of the microprocessor, coupled with the availability of inexpensive high density memory devices is resulting in a development of singular importance in the state of the art of electronics. This development, which provides inexpensive and reliable intelligence to the widest possible variety of equipment, ranging from toys and washing machines to supersonic aircraft and space probes, could revolutionise society. The Institution of Electronic and Radio Engineers conference on Microprocessors in Automation and Control at the University of Kent at Canterbury, in September 1978, will provide a forum for recent advances in the application of the latest technology on microprocessors through the medium of original technical papers and debate. The following list outlines the scope of the conference and shows the topics on which papers are solicited. The list is meant to be a guide and the organizing committee is prepared to consider papers in other areas which are appropriate to the general theme of the conference.

Industrial Automation, Telecommunication Systems, Interfaces, Commercial Applications, Social, Psychological and Financial Implications, Consumer and Entertainment Applications, Transport Systems, Security Applications, Medical Equipment, Military Systems, Educational and Instructional Uses, Software, System Simulation, Design and Development Aids, Energy Conservation, Systems Reliability and Maintenance and New Developments.

All enquiries to the Conference Secretariat, The Institution of Electronic and Radio Engineers, 99 Gower Street, London, WC2

(259 S)

Computer aid for IEA 78 visitors and exhibitors

One of the many special facilities provided for exhibitors and visitors at

IEA 78 - the 12th Instruments, Electronics and Automation Exhibition at the National Exhibition Centre, Birmingham, 13-17 March 1978 - will be a computerised visitor registration and enquiry system, operating in four languages.

The system will enable visitors to obtain specific-interest information on product categories, companies exhibiting, stand locations and so on. The system will provide an excellent two-way information service - benefiting visitors and exhibitors alike. Some 300 companies and organisations from the UK and countries in Europe, America and Asia have already reserved stand space for IEA 78.

The international influence of IEA 78 will be illustrated by exhibits from at least 17 overseas countries - to date these are Belgium, Canada, Czechoslovakia, Finland, France, East Germany, West Germany, Holland, Ireland, Japan, Monaco, Norway, Poland, Sweden, Switzerland, USA. IEA 78 will occupy the largest hall at the NEC and will have three sections - for Electronic Components, Process Control Instrumentation and a General classification. Products on show will include professional and industrial electronics, active and passive components, process control and scientific instrumentation, machine tool control and automation, computer techniques and data handling. The show will be the only recognised trade fair in 1978 covering the electronic and instruments industries in the United Kingdom. It will again be held alongside ELECTREX, the 19th International Electrical Exhibition, following the most successful coming together of the two shows in 1976 at the NEC.

For further information contact Industrial and Trade Fairs Limited, Radcliffe House, Blenheim Court, Solihull, West Midlands, B91 2BG

(257 S)

Cable testers use pulse 'radar' technique

The Tektronix 1502 and 1503 cable testers are small, portable, rugged, battery-powered instruments designed for locating and identifying faults and discontinuities in any type of cable. The testers use a system known as time-domain reflectometry, based on 'radar' type techniques of sending pulses down the cable and examining the characteristic shape and timing of the reflected pulse. The two testers cover the entire range of cable types from simple electrical connections to coaxial systems.

The Tektronix 1502 is a high-resolution instrument designed to locate faults to within 1½ centimetres over distances up to 600 m, and is ideal for checking

coaxial and other cables in aircraft, ships and radar systems. The 1503, on the other hand, is designed for long-range applications (up to 15 000 m) with a resolution of 1 m, and is appropriate for testing long runs of coaxial or twisted-pair cables in telephone and other communications applications.

Both testers are designed for use as field maintenance tools, and each weighs less than 8 kg. The units can operate for more than 5h on their internal batteries before recharging is required. A built-in cathode-ray tube provides facilities for direct visual observation and photography.



An optional plug-in Y-T chart recorder is available to provide a self-contained hard-copy capability. A plug-in X-Y output module can drive an external X-Y recorder.

The model 1502 high-resolution tester is directly calibrated in reflection coefficient (ρ) and distance, and is thus very simple to operate. It uses 110 ps step-type excitation signals, and provides fault resolution to within 1.5 cm. The tester is matched to 50 Ω cables, but may be used on other cables by adjusting a front-panel gain control or using optional impedance adaptors. Because the limited bandwidth and relatively high losses of long cables require special high-energy, controlled bandwidth test signals, the Tektronix 1503 provides 10 V, half-sinewave shaped pulses, and is calibrated in decibels for direct readings of return loss. Impedance levels of 50, 75, 93 and 125 Ω are pushbutton-selected.

Tektronix U.K. Ltd., Beaverton House, P.O. Box 69, Harpenden, Herts.

(258 S)

infra-red light gate

The use of an infra-red light source is an obvious choice for this type of application. In the first place, for intruder alarm applications the light beam must be invisible, which limits the choice to infra-red or ultra-violet light. Ultra-violet light can cause visible fluorescence of certain materials, which makes it less suitable than infra-red. In the second place, relatively powerful solid-state infra-red sources, and infra-red sensors, are available at modest cost, whereas there are no solid-state UV sources commercially available. The circuit described here uses the Siemens LD 241 infra-red emitter and BPW 34 IR photodiode.

Although these devices are not exorbitantly priced, neither are they inexpensive, so in order to minimise the number of IR emitters necessary to achieve a given range the transmission system should be as efficient as possible. Since the light level received at several metres distance from the transmitter will be very low, the receiver must have a high gain. This immediately excludes the simpler types of photoelectric switch that use a continuous light beam and a DC-coupled receiver, since a high-gain DC coupled receiver amplifier would be prone to offsets, temperature drift and other effects that could lead to poor sensitivity on the one hand, or false triggering on the other.

The choice therefore falls on an AC modulated light beam and AC-coupled receiver, since a high AC gain can be achieved without offset problems. Such a system can be either narrowband or wideband. The advantages of a narrowband system are a higher signal-to-noise ratio and less susceptibility to extraneous interference, either in the form of ambient light or transients on the supply lines. The disadvantage of a narrowband system is that the transmitter and receiver frequencies have to be accurately aligned.

In a wideband system, the light source is simply pulsed on and off, and the amplification stages of the receiver have a fairly large bandwidth. The advantages of this system are simplicity and ease of alignment, but the disadvantages are poor signal-to-noise ratio and susceptibility to interference. However, advan-

This article describes an infra-red light source and detector, which can be used in a wide variety of applications ranging from intruder alarms to automatic garage door openers. When the light beam from the infra-red source is interrupted, the receiver circuit detects this and energises a relay.

tage may be taken of the fact that the infra-red emitting diode will withstand a peak current that is much larger than the average current (1 A peak as against 100 mA continuous). Small duty-cycle, high-power pulses may thus be transmitted, which will give an improved signal-to-noise ratio over a larger duty-cycle transmission of the same average power.

The effects of external sources of interference may be reduced by careful attention to constructional layout, mounting the unit in a screened box, and suppression of the supply lines. With these precautions a wideband system can give quite acceptable performance and was thus chosen because of its other advantages.

Transmitter circuit

The simple transmitter circuit is shown in figure 1. It consists of a 555 timer connected as an astable multivibrator, driving an output transistor which switches the IR emitter on and off. The duration of the transmitted light pulses is about 10 μ s and the repetition rate is just less than 1 kHz. The average current drawn by the circuit is about 12 mA and the peak current through the IR diode is around 700 mA.

The LD241 is available in three versions, LD 241/I, LD 241/II and LD 241/III, which have different radiant intensities. For the same forward current, the light output of the LD 241/II is typically 1½ times, and the light output of the LD 241/III typically 2½ times, that of the LD 241/I.

The power supply for the transmitter is not critical provided the output voltage is no greater than 6 V, as this could result in the maximum current rating of the LD 241 being exceeded. A suitable circuit is given in figure 2 and can be built up on the board for the 'Local Radio' power supply (Elektor 22, February 1977).

Note that the component values for this circuit differ from those of the original circuit (see parts list) and that the following components are omitted: R5, C2 (replaced by R6), D1, D2, T1 (base and emitter connections linked on the p.c.b.).

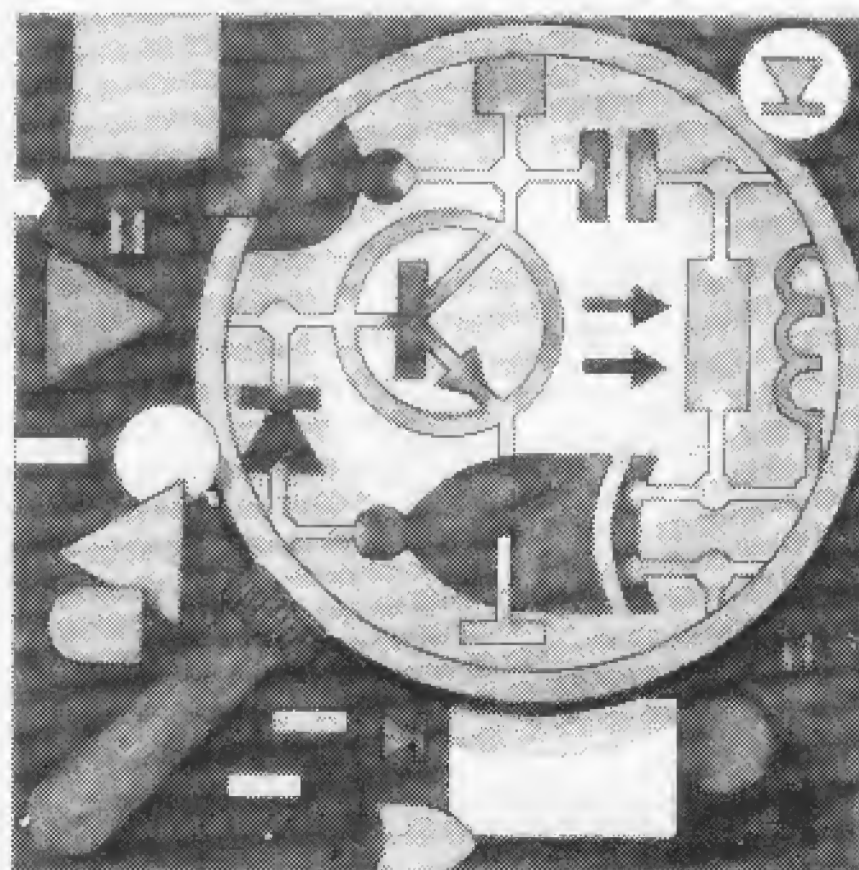

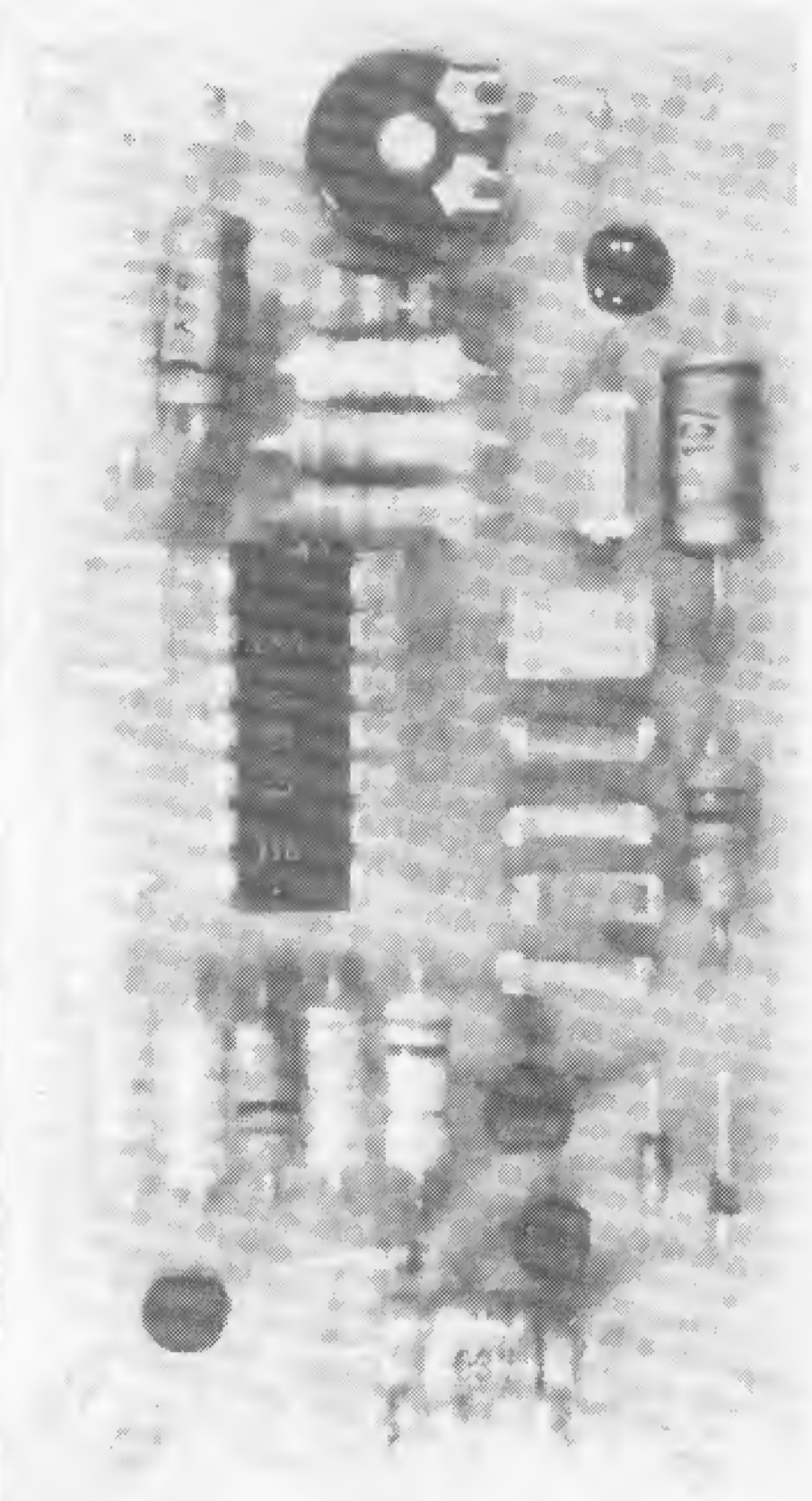
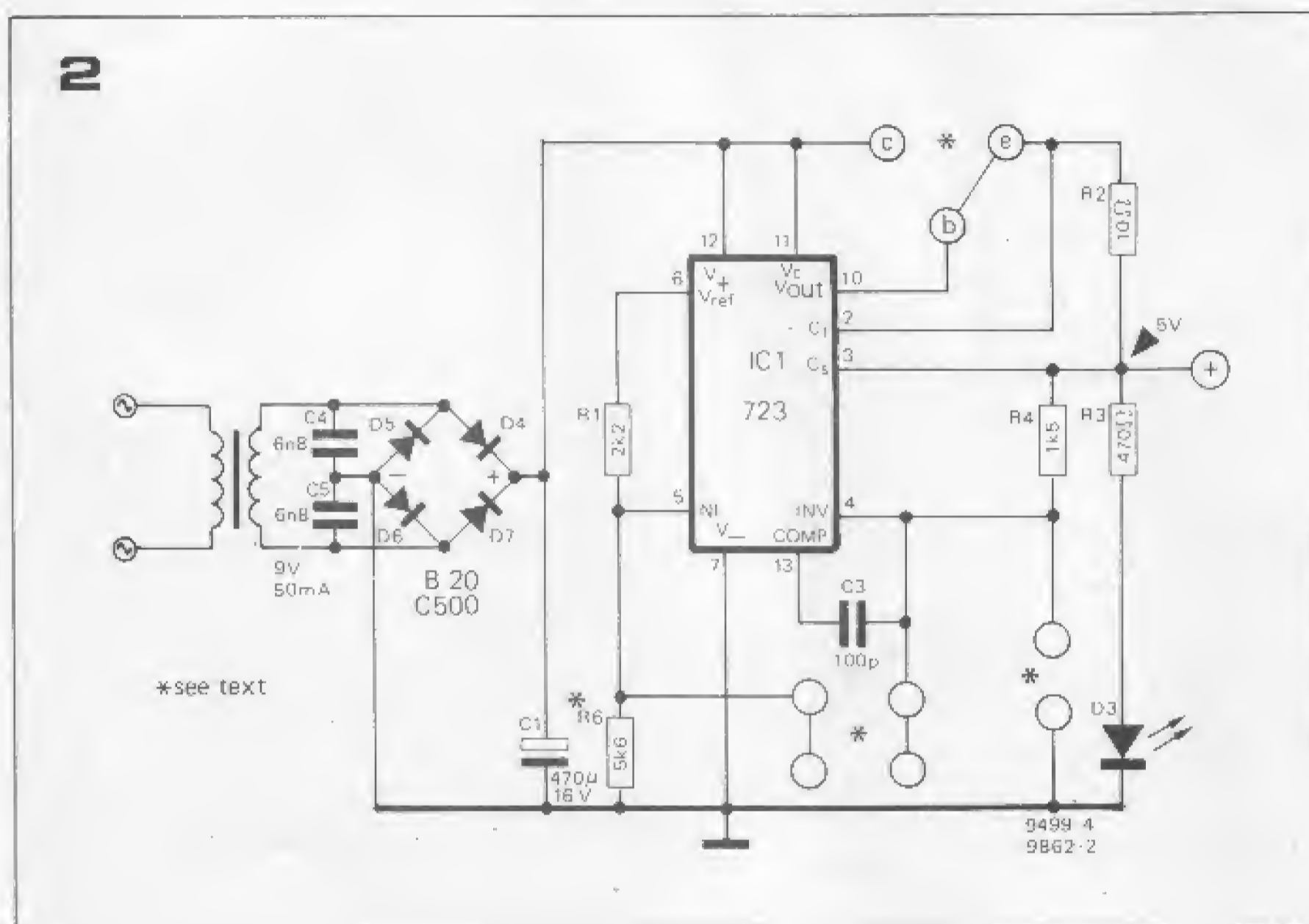
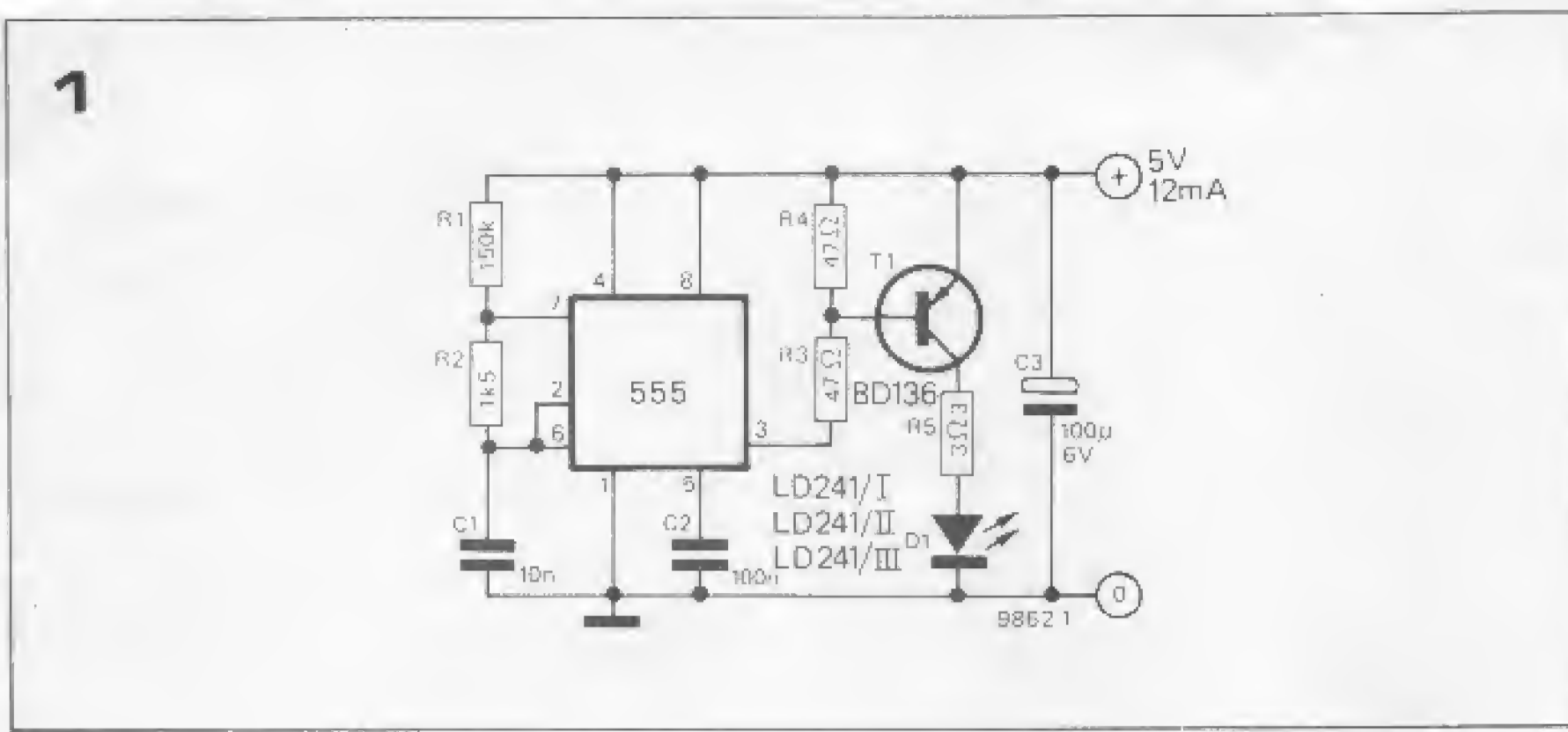

Figure 1. Circuit of the infra-red transmitter.

Figure 2. The 'Local Radio' power supply may be modified to provide a 5 V supply for the IR transmitter. Since the average current is only 12 mA, the external transistor T1 may be omitted.

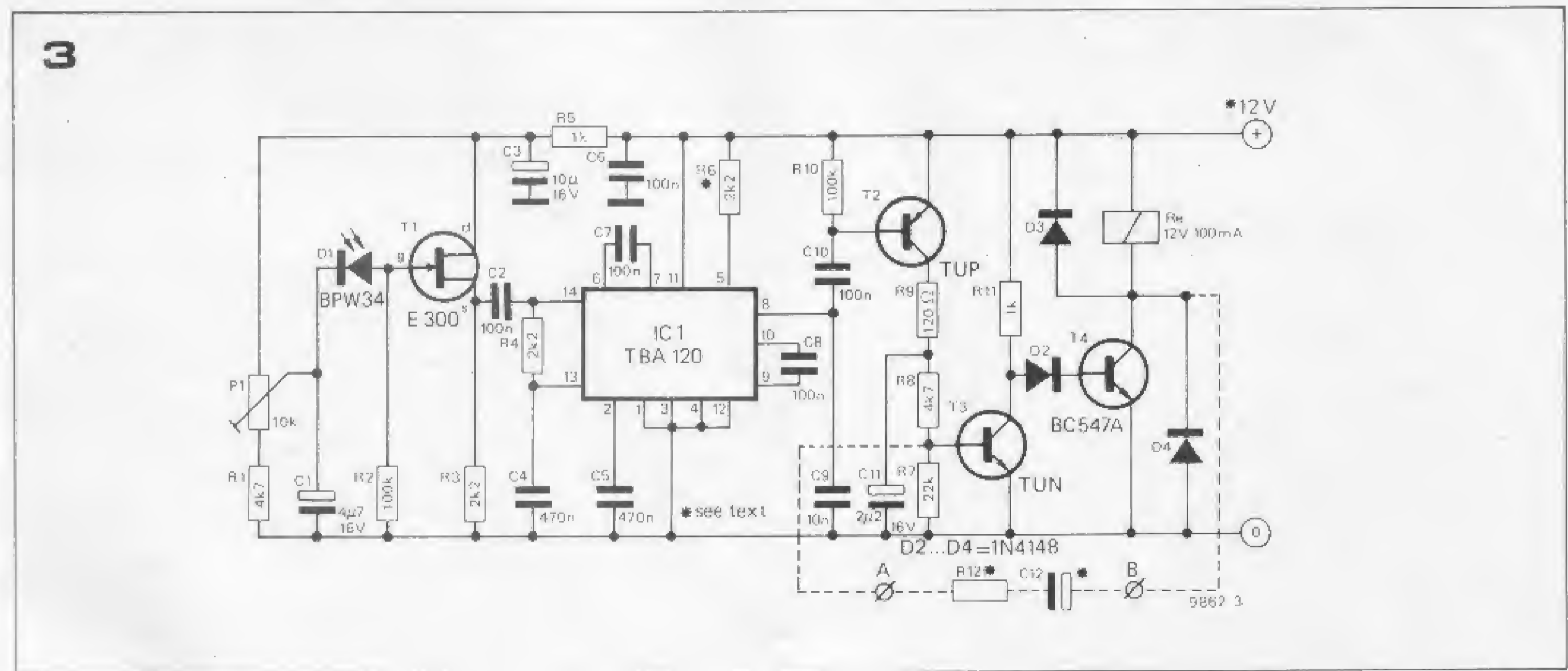

Figure 3. Circuit of the infra-red receiver.

Receiver circuit

The receiver circuit is shown in figure 3. A BPW34 infra-red photodiode is operated in the reverse-bias mode. The leakage current of this diode varies with the light received from the transmitter, which causes a varying voltage to appear across resistor R2, the gate resistor of the FET source-follower T1. The signal appearing at the source of T1 is fed to IC1, which is used as an ampli-

fier and limiter. P1 varies the sensitivity by altering the reverse bias voltage of the diode. When light pulses are being received from the transmitter, a negative-going pulse train with an amplitude in excess of 1 V peak-to-peak appears at the output of IC1 (pin 8). This turns T2 on and off continually, charging up C11. T3 is thus always turned on, T4 is turned off and relay Re is not energised.

When the light beam between the transmitter and receiver is interrupted, the amplitude of the pulse train from the output of IC1 will fall. T2 will be cut off, C11 will discharge, T3 will turn off and T4 will turn on, pulling in the relay. Once the light beam is restored the relay will, of course, drop out again, but can be made to hold in for several seconds after the light beam has been restored by adding the components shown dotted. R12 should be

4

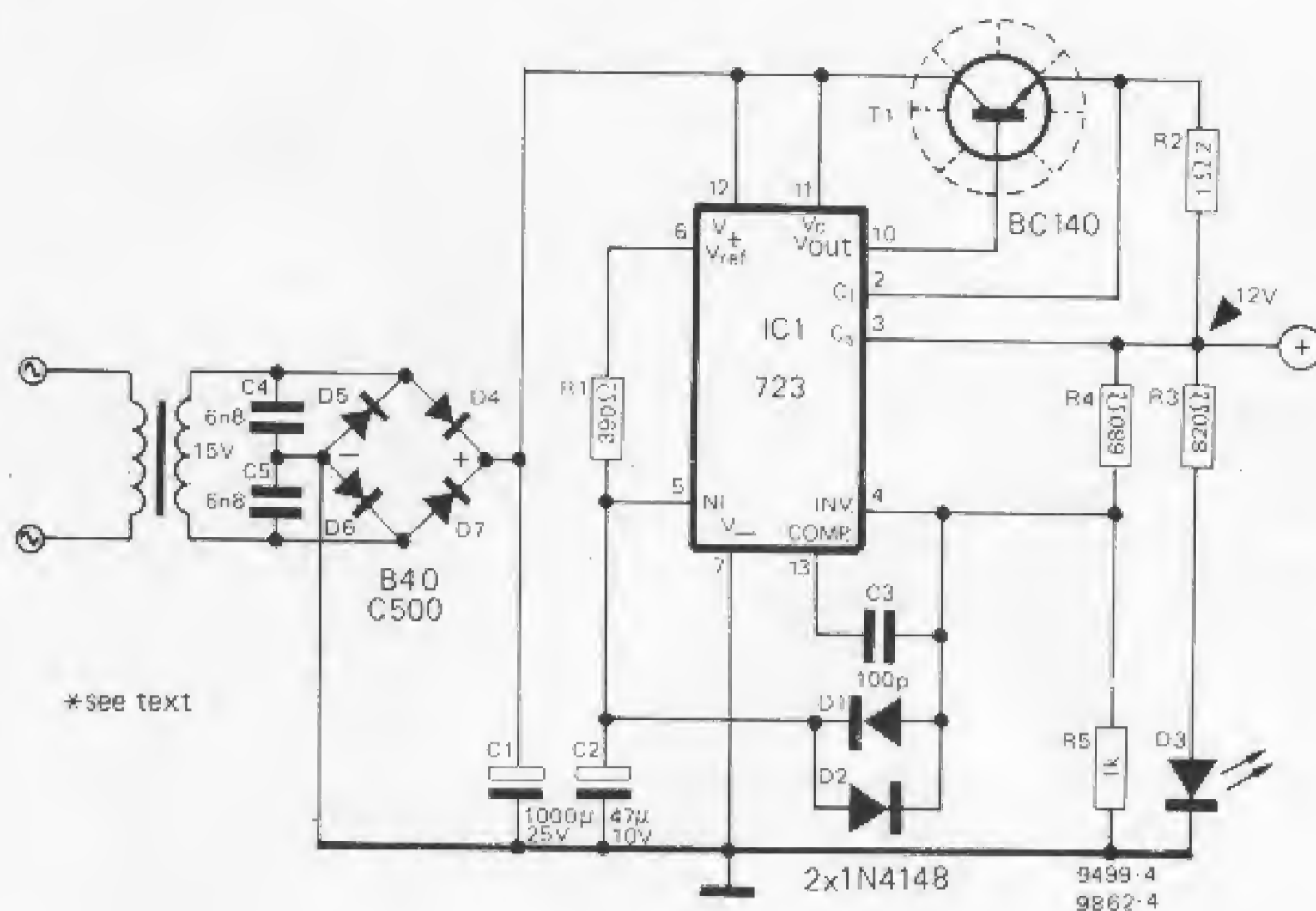

*see text

Figure 4. The power supply for the receiver is simply a 12 V version of the 'Local Radio' power supply.

Figure 5. Printed circuit and component layout for the transmitter. (EPS 9862-1).

Figure 6. Printed circuit board and component layout for the receiver (EPS 9862-2).

Figure 7. Printed circuit board and component layout for the power supplies (EPS 9499-2).

5

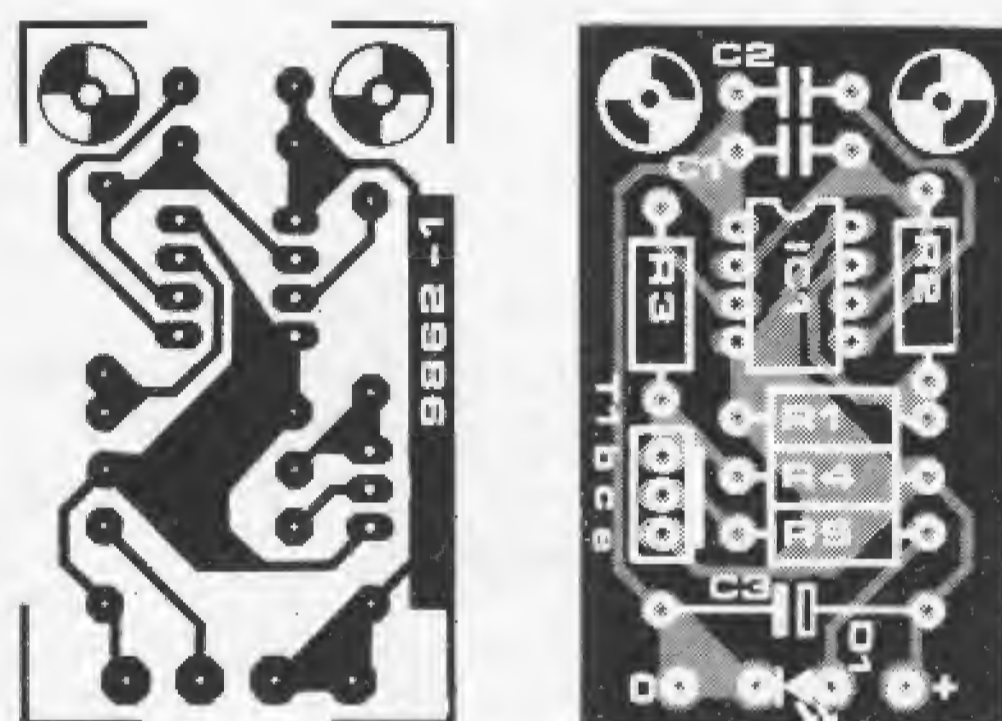

Parts list for figure 5

Resistors:

R1 = 150 k
R2 = 1k5
R3, R4 = 47 Ω
R5 = 3Ω3

Capacitors:

C1 = 10 n
C2 = 100 n
C3 = 100 µ/6 V tantalum

Semiconductors:

IC1 = 555 timer
T1 = BD 136
D1 = LD 241/I, II or/III

4k7 and C12 can be from 10 µ to 100 µ, depending on the desired hold-in time. Alternatively a latching arrangement may be used that will hold the relay in until a reset button is pressed.

Power supply

A power supply for the receiver circuit is shown in figure 4. This is virtually identical to the power supply for the 'Local Radio' and may be built on the same board.

Construction

Printed circuit board and component layouts for the transmitter and receiver are given in figures 5 and 6. Construction of the transmitter should present no problems.

When constructing the receiver, great care must be taken with the layout due to the high sensitivity and large bandwidth. The leads to the BPW 34 photodiode must be as short as possible, as otherwise they may pick up interference. The relay should preferably *not* be housed in the same box as the receiver, as the magnetic field set up when it is energised may completely saturate the

sensitive receiver input stage, causing the relay to drop out immediately. The receiver will then begin to function again, the relay will pull in and the whole process will repeat. If the relay must be mounted in the same box as the receiver, then it should be mounted as far as possible from the receiver input stage, and must be magnetically and electrically screened.

The receiver itself should be mounted in a metal box for screening, the only holes in the box being for relay and supply leads, an adjustment hole for access to P1 and a hole for the photodiode. Since the photodiode is sensitive to visible as well as infra-red light, it must be fitted with an infra-red filter (obtainable from photographic suppliers) if the unit is to be used in daylight. Even with the infra-red filter, direct sunlight should not be allowed to fall on the photodiode, since its large infra-red content could affect the diode biasing and hence the receiver sensitivity. Some kind of hood or tube to screen the diode may be necessary in such circumstances.

Adjustment

The transmitter diode and receiver diode should be aligned with one another, although the radiation pattern of the one and the acceptance angle of the other are so wide that a slight misalignment will have little effect (but remember that a screening hood or tube on the photodiode will reduce the acceptance angle). The circuit is then checked for reliable operation at close range by breaking the infra-red light beam, after which the transmitter and receiver are moved progressively further and further apart, whilst P1 is adjusted to obtain the maximum range. If the photodiode is well screened from ambient light, this adjustment will have little effect and the wiper of P1 can simply be turned fully clockwise.

As it stands, the circuit will function at distances of up to 6 meters between the transmitter and receiver. If lenses are used to concentrate the transmitted light into a much narrower beam and to focus the received light on the photodiode then much greater ranges can be achieved. However, the physical

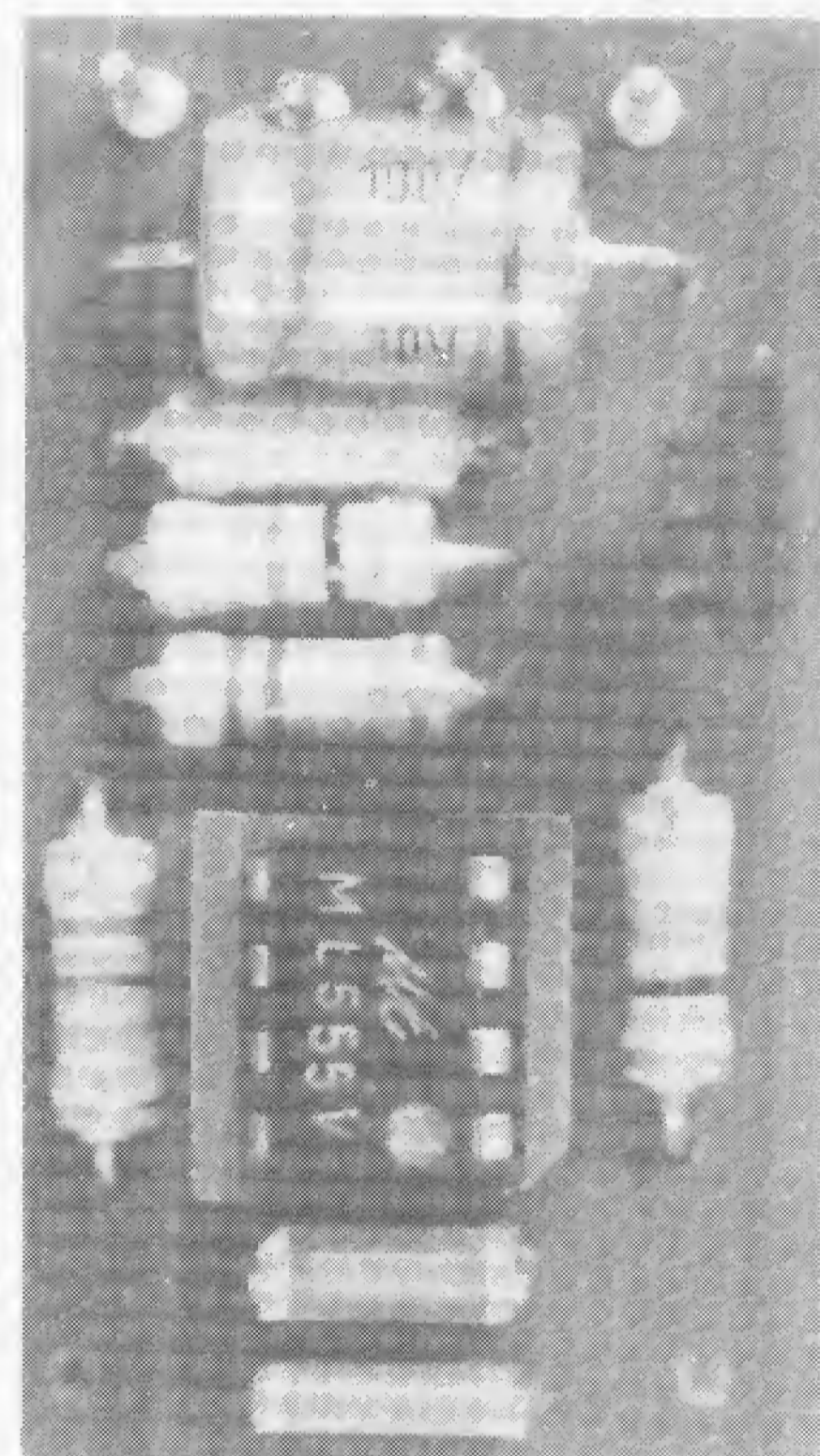

6

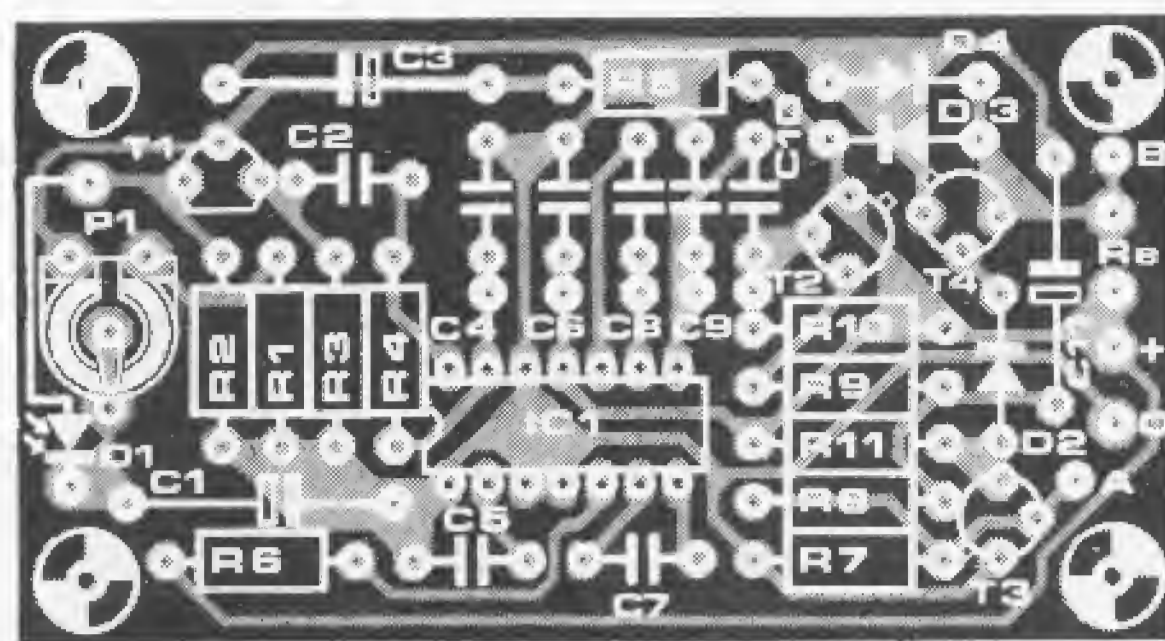
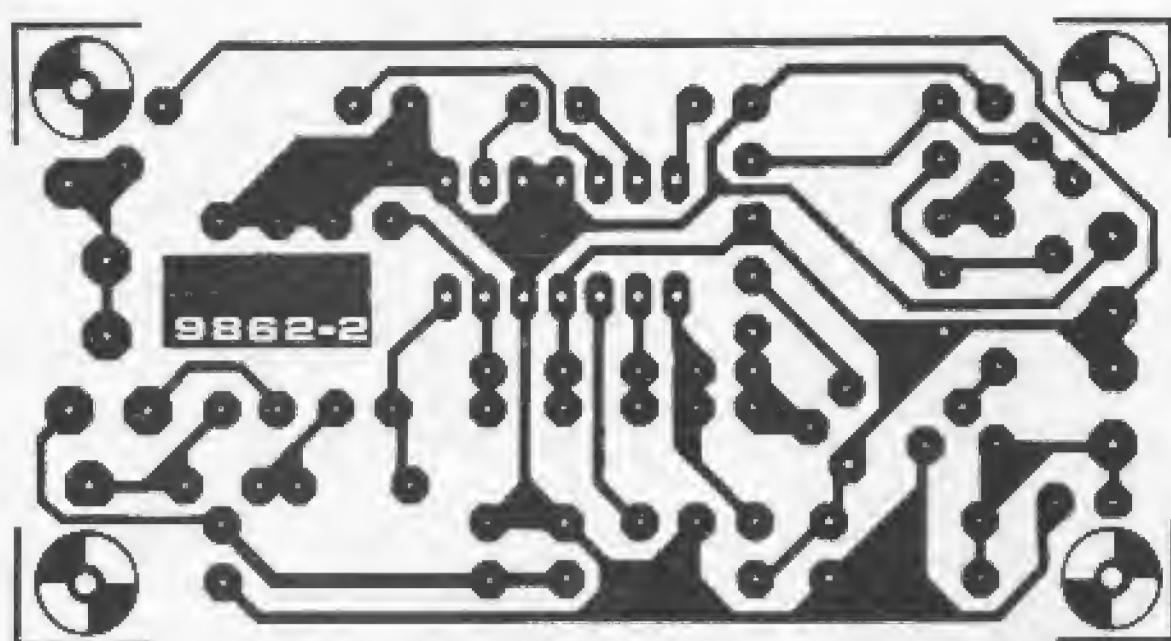

Parts list for figure 6

Resistors:

- R1, R8 = 4k7
- R2, R10 = 100 k
- R3, R4, R6 = 2k2
- R5, R11 = 1 k
- R7 = 22 k
- R9 = 120 Ω
- R12 = see text

Capacitors:

- C1 = 4μ7/16 V
- C2, C6, C7, C8, C10 = 100 n
- C3 = 10 μ/16 V
- C4, C5 = 470 n
- C9 = 10 n
- C11 = 2μ2/16 V
- C12 = see text

Semiconductors:

- IC1 = TBA 120
- T1 = E 300
- T2 = TUP
- T3 = TUN
- T4 = BC 547A, BC107A
- D1 = BPW 34 IR photodiode
- D2, D3, D4 = 1N4148

Miscellaneous:

- P1 = 10 k preset
- Re = relay with 12 V/100 mA(max) coil

7

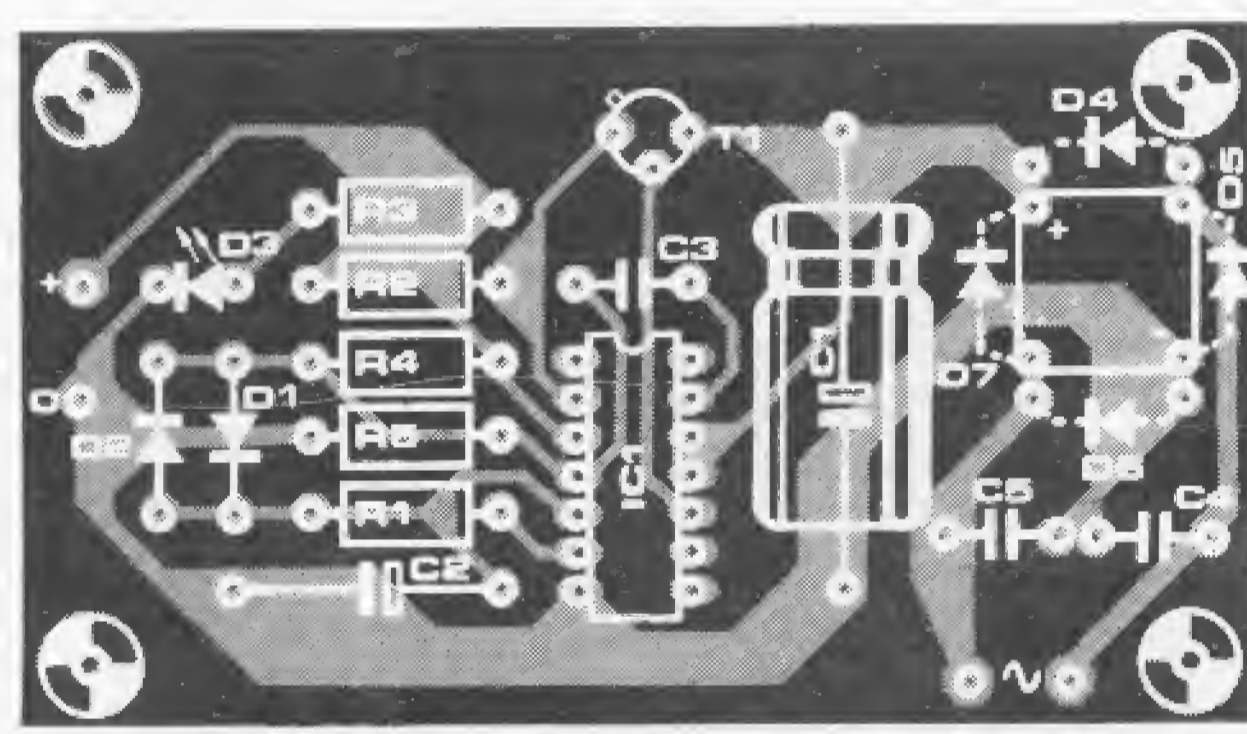
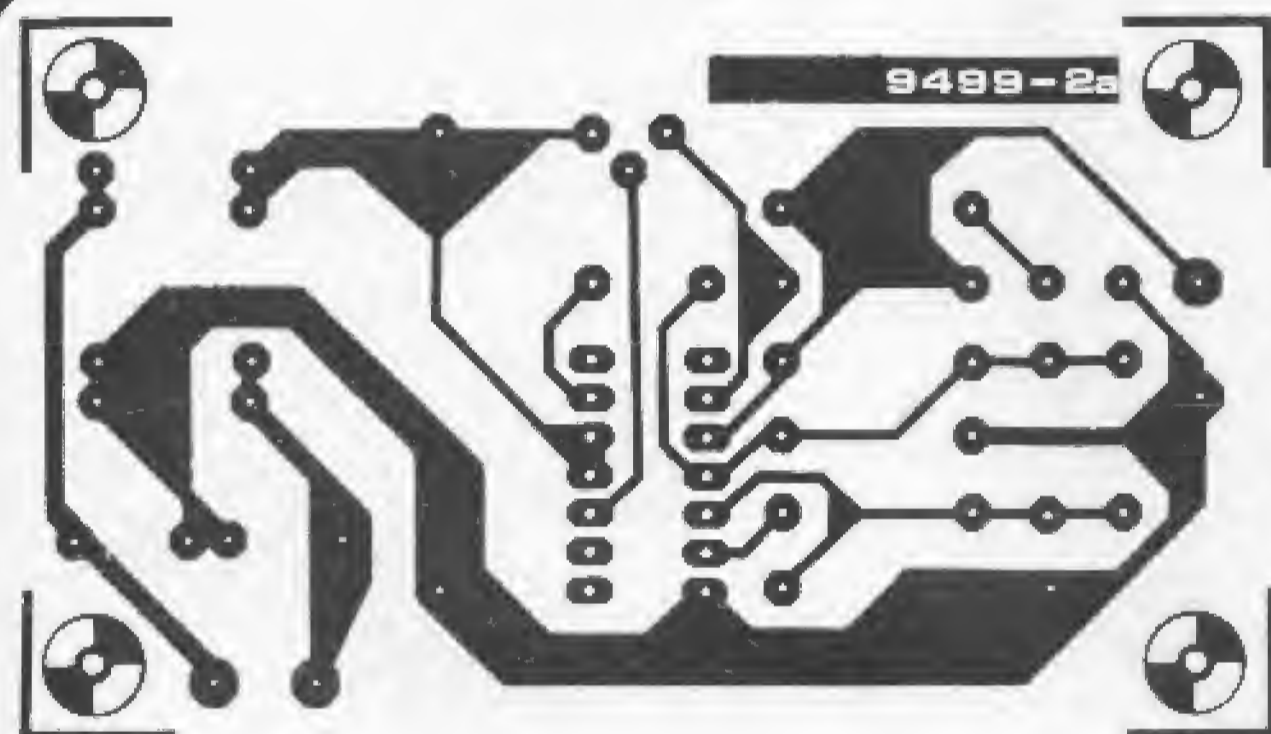

Parts list for figure 7, for circuit shown in figure 2:

Resistors:

- R1 = 2k2
- R2 = 10 Ω
- R3 = 470 Ω
- R4 = 1k5
- R5 = omitted
- R6 = 5k6 (replaces C2 on p.c.b.)

Capacitors:

- C1 = 470 μ/16 V (tantalum)
- C2 = replaced by R6
- C3 = 100 p
- C4, C5 = 6n8

Semiconductors:

- T1 = omitted
- IC1 = 723
- D1, D2 = omitted
- D3 = LED
- D4 ... D7 = 4 x 1N4002, or 20 V 500 mA bridge rectifier

Miscellaneous:

- Transformer = 9 V 50 mA sec.

Parts list for figure 7, for circuit shown in figure 4:

Resistors:

- R1 = 390 Ω
- R2 = 1 Ω
- R3 = 820 Ω
- R4 = 680 Ω
- R5 = 1 k

Capacitors:

- C1 = 1000 μ/25 V
- C2 = 47 μ/10 V
- C3 = 100 p
- C4, C5 = 6n8

Semiconductors:

- T1 = BC 140
- IC1 = 723
- D1, D2 = 1N4148
- D3 = LED
- D4 ... D7 = 4 x 1N4002 or 40 V/500 mA bridge rectifier

Miscellaneous:

- Transformer = 15 V/250 mA sec.

alignment of the transmitter and receiver will then be much more critical.

Notes on the TBA 120

The TBA 120 is produced by several manufacturers, and several different versions are available. All of these should function satisfactorily in the receiver circuit. However, in some cases it may be necessary to omit R6 (see figure 3) or connect it to ground instead of +U_b, to obtain the best signal-to-noise ratio. To check this the output of the IC should be monitored, either on an oscilloscope, or by connecting a pair of high impedance (> 500 Ω) headphones between pin 8 of the IC and +U_b. When receiving a signal from the transmitter a 1 kHz signal should be heard (or seen). The effect of omitting R6, or connecting it to ground, can thus be investigated. The optimum result is indicated by the loudest (highest amplitude) signal. Care should be taken when altering R6 not to disturb the relative positions of the receiver and transmitter, as this could give false results.



throwing some light on LEDs

Light emitting diodes were first made in 1954, when it was discovered that a point-contact diode made with gallium phosphide (GaP) as the base material emitted red light when forward biased. Although it was realised that this material offered the prospect of making a commercial solid-state light source, the physics of light emission from semiconductors was poorly understood, the technology to make the material was difficult, involving high temperatures and pressures, and it was some time before commercial devices appeared. Early LEDs were packaged in metal TO-18 type transistor housings, with a glass or plastic end window or lens, and costs were initially very high; furthermore, one could have any colour, provided it was red. Efficiency (i.e. light output for a given power input) was also very low.

When the phenomenon of semiconductor light emission was better understood, it was realised that the red emission of early GaP diodes was due to zinc and oxygen impurities in the GaP material. LEDs made with purer GaP produce a green light. Various exotic semiconductor materials for LEDs have now been developed, but the most common compound used is gallium arsenide phosphide (GaAsP). The advantage of this material is that the colour of light emitted can be varied by altering the proportions of arsenic and phosphorus in the material, from infra-red radiation, obtained with pure GaAs, to green radiation, obtained with pure GaP. At present there is no commercially available LED that emits blue light.

The most popular colour for LEDs is still red, using GaAsP material with the formula $\text{GaAs}_{0.6}\text{P}_{0.4}$ (i.e. the ratio As:P is 6:4). LEDs using this material are easiest (and hence cheapest) to produce, and have the highest efficiency. Green LEDs are the least efficient, but this disadvantage is offset to some extent by the fact that the human eye is more sensitive to green light than to red light.

LEDs are now commonly available in four colours; red, orange, yellow and green. An important factor to be considered when choosing the colour of

Light-emitting diode (LED) lamps are replacing incandescent filament lamps in a variety of indicator applications, as they offer improved reliability and performance at a comparable price. A bewildering variety of LEDs of different shapes, sizes, colours and prices is now available, and the amateur constructor may find it difficult to choose a device for a particular project, especially if the parts list simply says that a 'LED' should be used, with no indication of type. This article aims to dispel some of the mystery surrounding LEDs, so that the constructor can choose the most suitable type for his requirements, and calculate the operating conditions.

a LED is the proposed application. For example, red is conventionally used for warning lights, but green and yellow may be aesthetically more pleasing for other purposes.

Cost is always an important consideration. Green and yellow LEDs may be up to twice as expensive as red LEDs, as well as being less efficient. This inefficiency is not necessarily a disadvantage, provided low-current (e.g. battery) operation is not required. For comparable light output from a green LED it may be necessary to run it at twice the current of a red LED, but if a mains power supply is available this is no great problem, provided the ratings of the LED are not exceeded.

In general, it is true to say that, in terms of efficiency, 'yer gets what yer pays for' with LEDs. The high-efficiency, 'state-of-the-art' devices now appearing on the market are considerably more costly than the less efficient second generation devices that are commonly available to the amateur constructor, since the technology required to make high-efficiency LEDs is considerably more difficult, and development costs still have to be recouped.

Packaging

The high cost of the early LEDs was partly due to the expensive metal-can package, which is still used for some military and industrial devices. Modern consumer LEDs utilise a much cheaper form of encapsulation, the semiconductor wafer and its leadouts simply being encapsulated in a moulded epoxy resin housing. A typical selection of modern, epoxy-encapsulated LEDs is shown in photo 1.

Although the diode junction is essentially a point source of radiation, the encapsulation can have a profound effect upon the radiation pattern of the LED. For example, if the epoxy encapsulation is transparent then the LED functions as a point source, with the emitted light being confined to a relatively small angle, as shown in figure 1a. If the epoxy material is translucent, then the light produced by the LED is diffused over a much wider

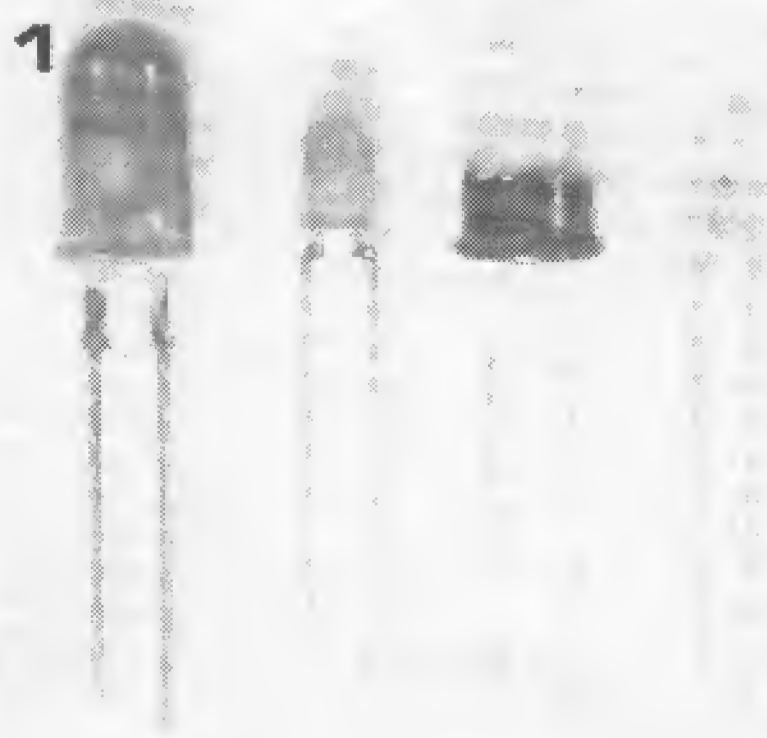

1a

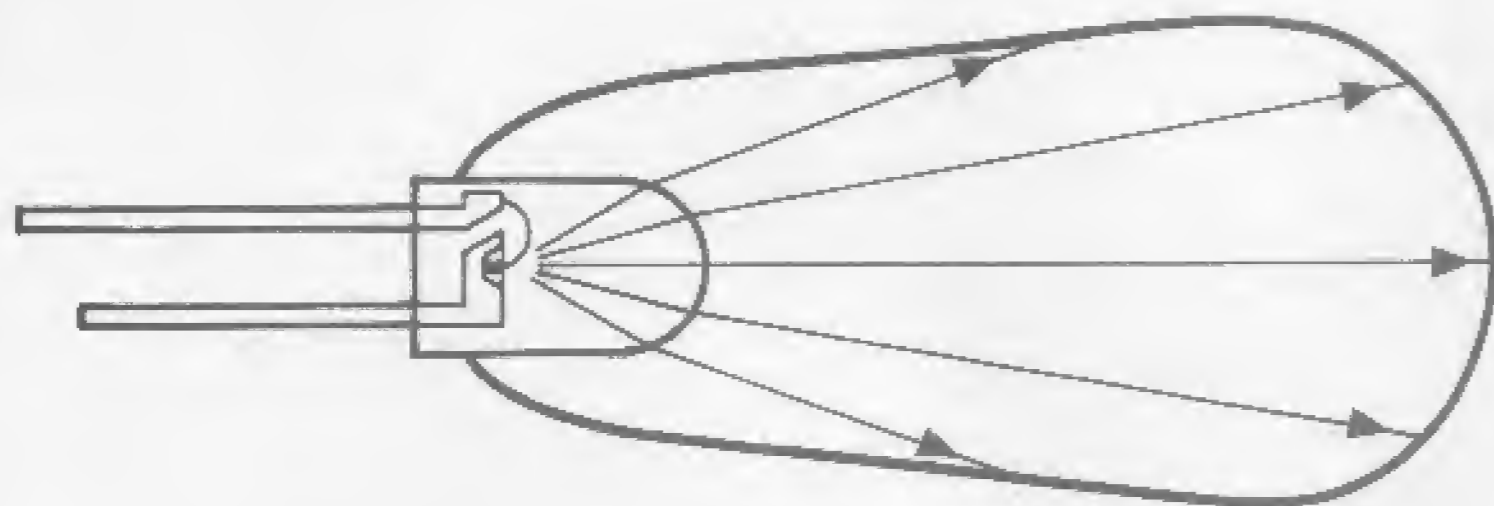

1b

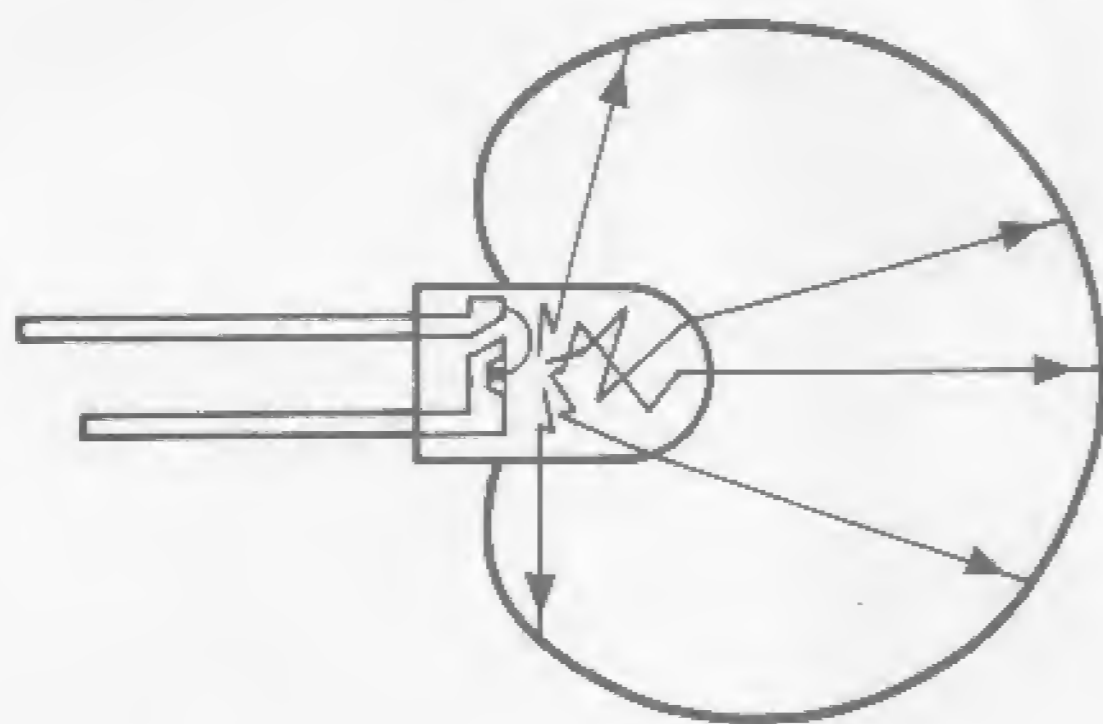

9852 1a

Figure 1a. A point source LED produces a fairly narrow beam of light.

Figure 1b. A diffuse LED produces a much more even radiation pattern, and has a wider viewing angle.

Figures 2a and 2b. The LED encapsulation acts as a lens, the shape of which has a marked effect on the radiation pattern.

Photo 1. A typical selection of commonly available LEDs.

angle, as shown in figure 1b. For a given light output from the LED chip, the point source LED will appear brighter, when viewed on axis, than the diffuse LED. However, off axis the brightness of the point source LED falls off rapidly, while the diffuse LED provides even illumination over a much wider viewing angle.

The shape of the encapsulation also has a marked effect on the radiation pattern, since it acts as a lens. For example, a LED in a cylindrical encapsulation with a domed end produces a radiation pattern as shown in figure 2a, whereas one with a parabolic cross-section produces the radiation pattern in figure 2b. It is apparent that the radiation pattern of figure 2b would produce much more even illumination of a plane surface placed at right-angles to the axis of the LED.

As well as being transparent or translucent, the LED encapsulation may be either clear or coloured. Of course, a coloured encapsulation does not influence the colour of light emitted by the LED, this is determined by the semiconductor material. If a coloured encapsulant is used it must be the same colour as the light emitted by the LED, otherwise the light output will be seriously attenuated.

Special packages

Most commonly available LEDs have a circular cross-section, for the simple reason that, for panel mounting purposes, round holes are easiest to

2a

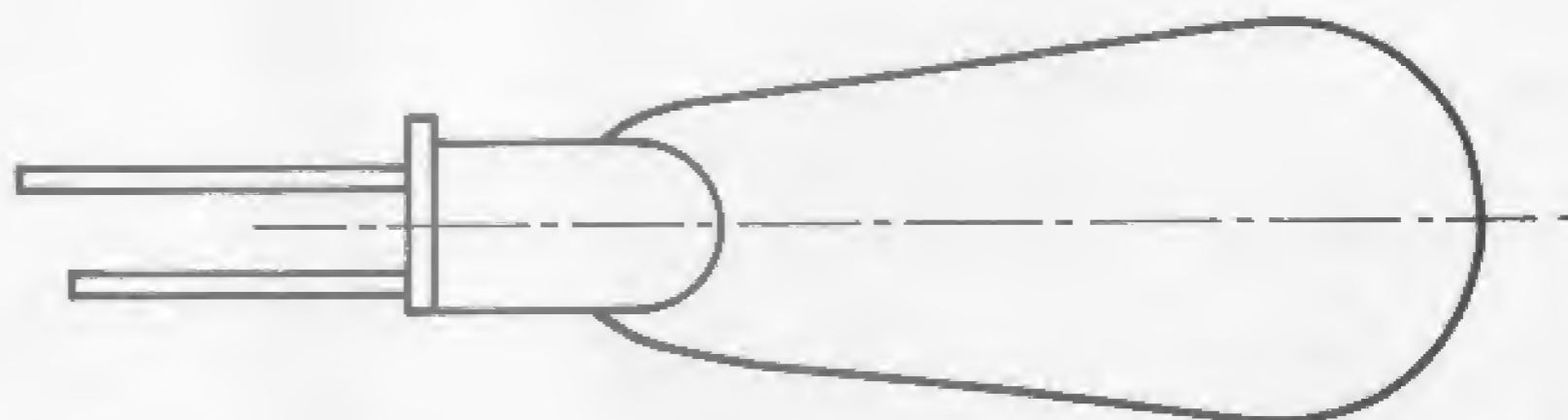

2b

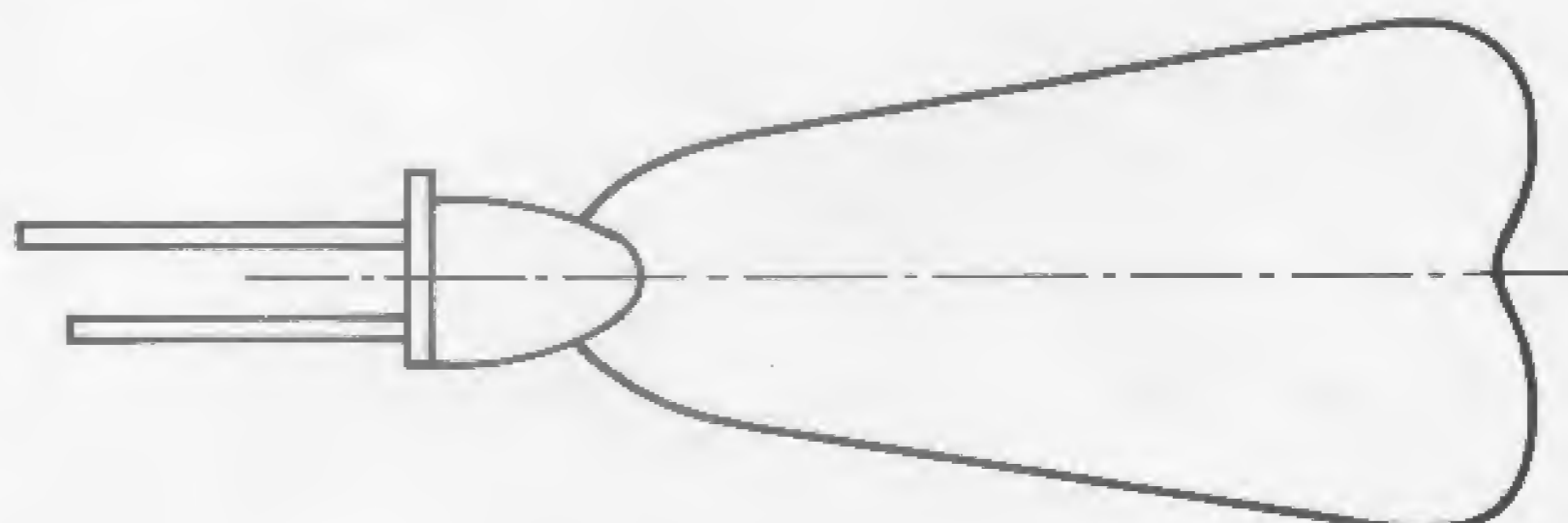

9852 1b

drill. However, with the demand for types of LED display other than single panel lamps (e.g. bar graph type displays), different types of package have appeared. Photo 2 shows a LED which has a flat rectangular cross-section with a rounded top. The dimensions of this type of LED (2.5 x 5 mm cross-section) allow it to be stacked on a standard 2.54 mm (0.1") pitch, to form arrays for such applications as audio level meters.

Another interesting shape is shown in photo 3. This type of LED has a transparent plastic case fitted with a flat diffuser screen, which makes it particularly suitable for backlighting of legends. In fact, press-on lettering or transfers can be applied direct to the diffuser screen.

Integrated LED arrays, housed in dual-in-line packages, are also becoming quite popular. Such an array of 10 LEDs is shown in photo 4.

Electrical characteristics of LEDs

Electrically, LEDs behave like normal semiconductor diodes, which is not surprising, since they consist of a single PN junction. However, the forward voltage drop of LEDs is considerably greater than that of, say, a silicon diode. Furthermore, this forward voltage drop is not the same for all LEDs: it depends on the type and colour. Earlier types of LED had forward voltages varying from around 1.6 V for red, to around 2.4 V for green. However, modern high-efficiency LEDs tend to have forward voltages around the 2 V mark, irrespective of colour.

As with normal diodes, the forward resistance of LEDs is very low, which means that once the forward voltage is exceeded the current through it will increase very rapidly for only a very small increase in voltage. This makes it essential to use an external, series, current-limiting resistor if the LED is to

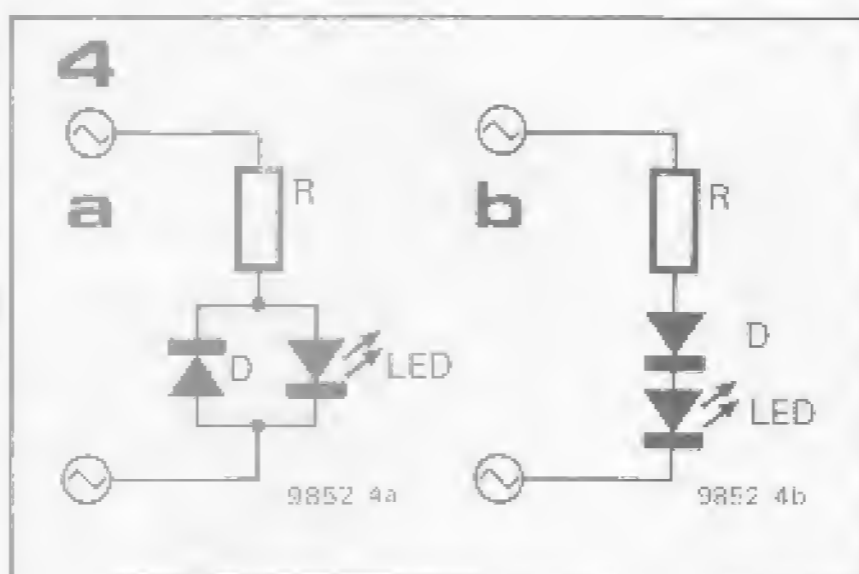
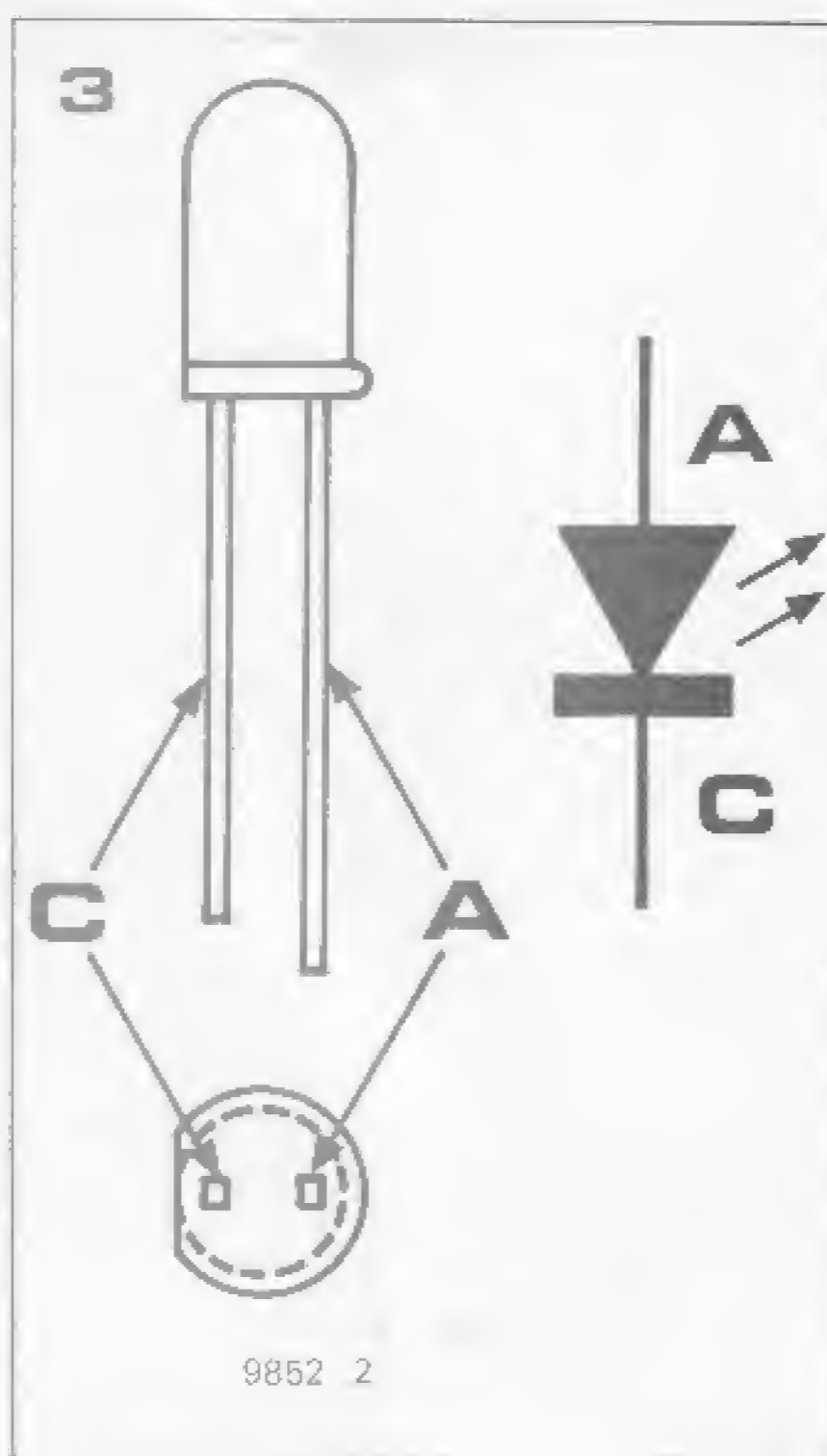

be connected to a voltage source. For DC operation, the required series resistor is found from the equation:

$$R = \frac{U_s - U_f}{I}, \text{ where}$$

U_s = supply voltage
 U_f = LED forward voltage
 I = required current

If data on a LED is unobtainable (e.g. unmarked, untested types) then as a rule of thumb, most LEDs will withstand a forward current of up to 40 mA (many will withstand more and only a few types will withstand less). Using 2 V as a value for the forward voltage drop will also not be far out.

However, if a LED is to be used with a low supply voltage then extra care must be taken not to operate the LED too near its maximum current, since a small variation in the supply voltage could lead to a large increase in current.

Care should also always be taken to connect LEDs the correct way round, since they have a very low reverse-breakdown voltage (typically 4 V) and are easily destroyed by excessive reverse voltages. For this reason great care should always be taken when trying to identify the leadouts of an unknown LED. A 3 V supply with a 150 Ω series resistor should be fairly safe. However, most manufacturers identify the leadouts of LEDs in one of two ways. The cathode, which is connected to the more negative supply voltage, has a shorter leadout than the anode (which is connected to the more positive supply voltage), or else the LED package has a flat side next to the cathode leadout (this only applies to circular cross-section LEDs). These identification marks are shown in figure 3.

AC operation

LEDs can be used to replace low-voltage incandescent lamps where only an AC supply voltage is available. The LED conducts only on one half cycle of the AC waveforms and is reverse biased on the other half cycle. The LED must therefore be protected from excessive reverse voltages. This can be done by connecting a diode in reverse parallel with the LED, as shown in figure 4a. The diode conducts on the negative half-cycle of the waveform and this limits the reverse bias on the LED to the diode forward voltage drop.

Another method is to connect a diode with a high breakdown voltage (greater than peak supply) in series with the LED, as shown in figure 4b.

The first method has the advantage that the diode need not have a high reverse breakdown voltage, since it is protected by the LED. However, it has the disadvantage that current flows through the series resistor during the whole cycle, so the resistor dissipates twice as much power as in the second circuit, where the resistor conducts only on positive half-cycles of the waveform.

In either case, when calculating the resistor value it is important to remember that the LED is conducting for only half the time, so the average LED current will be only half that expected from the calculated resistor value. To allow for this the approximate required resistor value is obtained from the equation:

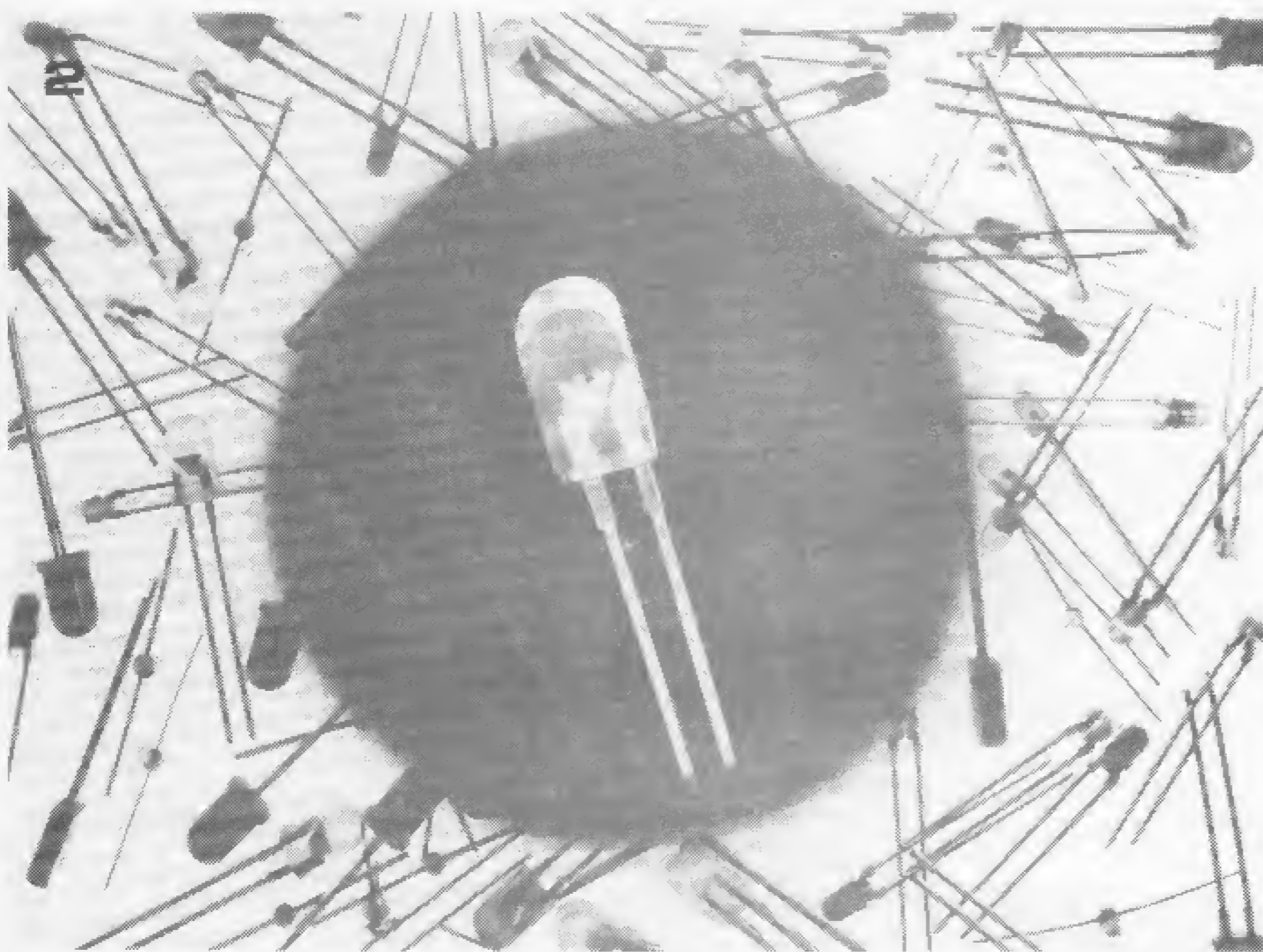

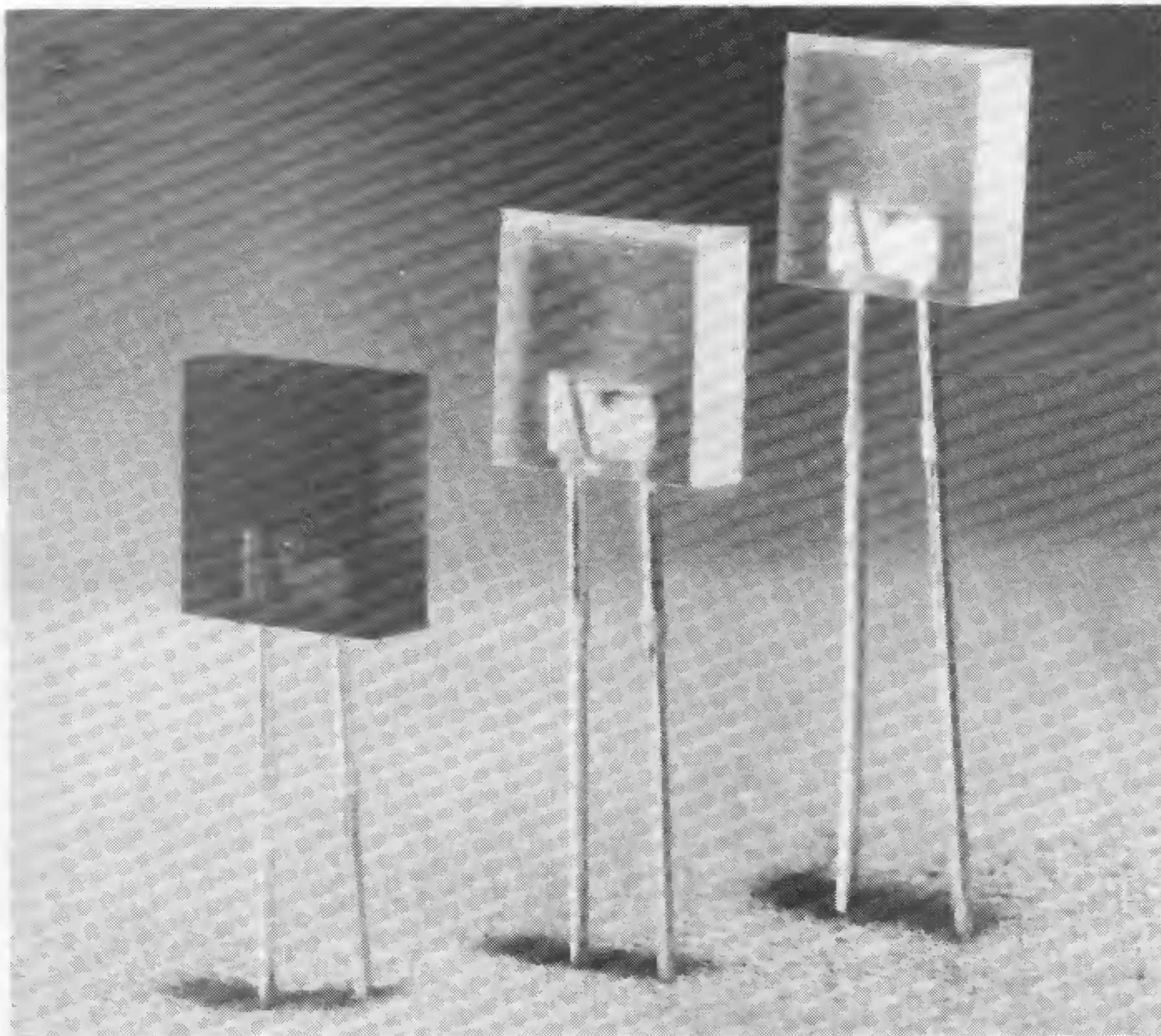

angle) than a comparable diffuse LED. If high light output and/or low power consumption are prime considerations, then it is worth considering a high-efficiency LED from a reputable manufacturer, though this will inevitably be more expensive.

For special applications, such as bargraph type displays, interesting possibilities are offered by the integrated LED arrays and the new shapes of LED packages now available.

Readers wishing to pursue the subject further are recommended to read the

'Optoelectronics Applications Handbook' from Hewlett-Packard. ■

$$R = \frac{U_{RMS} - U_f}{2I}, \text{ where}$$

U_{RMS} = AC supply voltage
 U_f = forward voltage of diode(s)
 I = required average current

The protecting diode must have a current rating greater than I .

Lifetime of LEDs

Early LEDs had problems with copper contaminants poisoning the diode junction, which caused a reduction in brightness after only a few hundred operating hours. Modern LEDs, however, if properly treated, should have an operating life of at least 100,000 hours, and possibly up to 1,000,000 hours (defined as the time taken for the light output to fall to 50%).

For the constructor, ensuring that a LED has a long life starts with careful handling of the device. The leads of a LED should never be bent closer than about 2 mm from the encapsulation; pliers should always be used to relieve the strain, otherwise the package could be damaged, resulting at best in the ingress of moisture, and at worst in complete disintegration of the package. When soldering LEDs the junction temperature should never be allowed to exceed 125°C, so a heat shunt should be used on the leads.

LEDs should not be operated at excessive temperatures. A LED operating at a temperature of 75°C produces only half the light output that it does at 25°C and also has a shorter life. The rule as far as the constructor is concerned is thus to keep LEDs away from hot spots in equipment, and not to operate them too near their maximum current rating.

Conclusion

To sum up, the choice of a LED for a particular application should be based on several criteria. For general indicator lamp applications in mains powered equipment, most LEDs are adequate, and the choice can be made on the basis of cost and the required colour. If a narrow viewing angle is acceptable, then a point-source LED will give greater apparent brightness (within its viewing

Figure 3. The leadouts of a LED may be identified by a shorter lead for the cathode, or a flat on the package next to the cathode.

Figures 4a and 4b. Two methods of connecting a LED for AC operation.

Photo 2. LEDs are also available in a rectangular package with a half-round end, specifically for use in arrays.

Photo 3. These LEDs are fitted with a flat diffuser screen, and are ideal for back illumination of legends.

Photo 4. An array of 10 LEDs housed in a dual-in-line package.

4

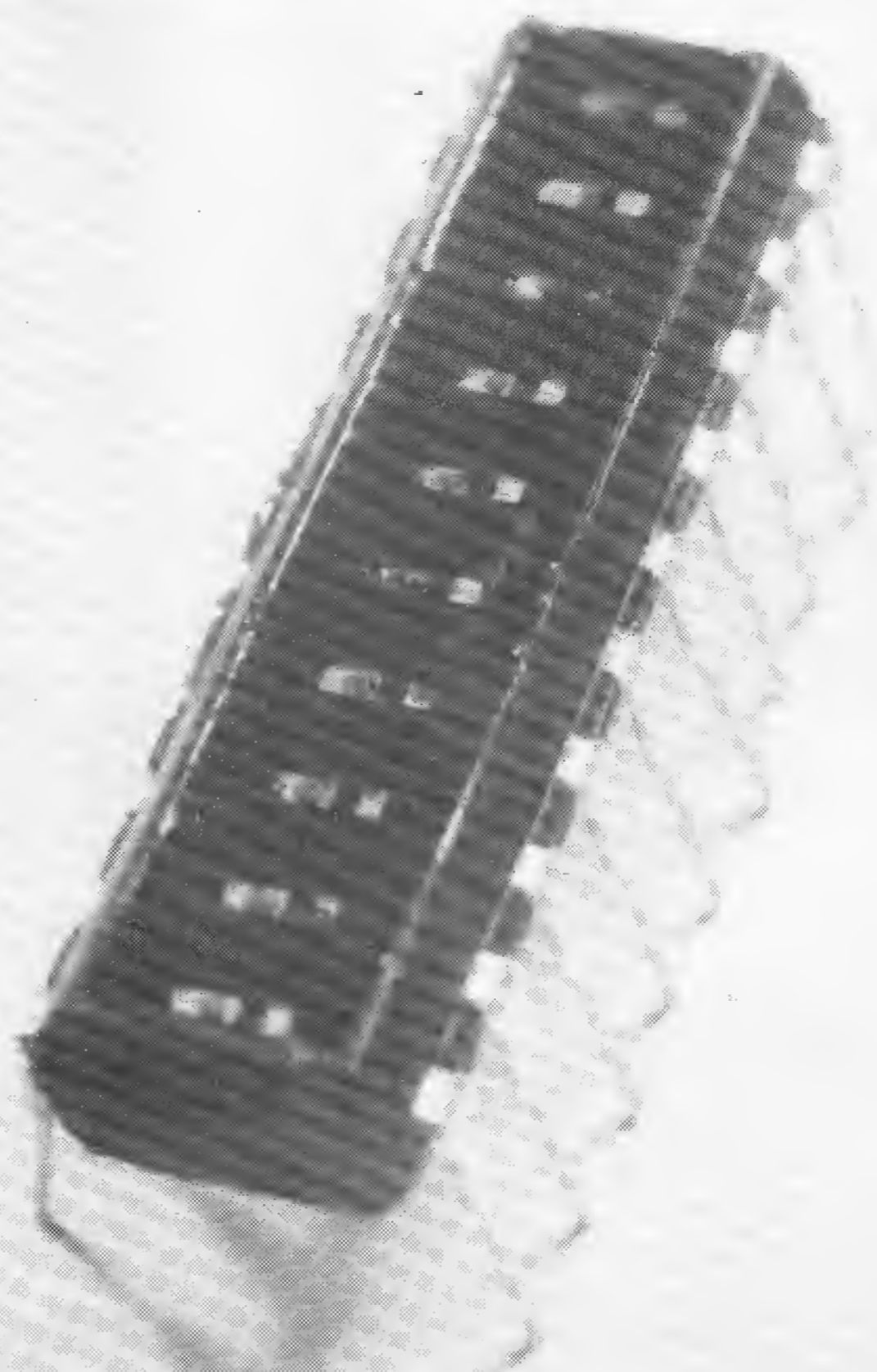

formant

the elektor music synthesiser (8)

The voltage controlled amplifier module is called a 'Dual VCA' because it contains two cascaded, but independently controlled, amplifiers. The gain of the first amplifier is voltage controlled via an exponential converter, and is used for envelope shaping. The second has a linear gain-control input and is used for periodic modulation of signal amplitude (tremolo). The VCA is provided with a modulation indicator, which allows the best compromise to be obtained between signal-to-noise ratio and overload margin.

Connection of the VCA in the synthesiser system

Figure 1 illustrates how the VCA fits into the synthesiser system. The VCA takes its input from the output of the VCF, which in turn takes its input signal from the VCOs.

The VCF and VCA can both be controlled by the ADSR envelope shapers, so allowing dynamic variation of tone colour and amplitude during the playing of a note. However, the VCF has a KOV input from the keyboard to allow it to function as a tracking filter, but the VCA lacks this, since there is no pitch related control of signal amplitude.

Using the VCA and the VCF

It may be interesting at this point to spend a little time comparing and contrasting the effects produced by the VCA and VCF, and discussing how they are used to complement one another in the synthesiser system. As an example, consider the case where the VCA and VCF are both controlled by the same waveform from the envelope shaper, consisting of a rapid attack and a relatively slow exponential decay, as shown in figure 2a, and are fed with a 440 Hz sawtooth waveform.

If the VCF is used alone in the lowpass mode and the cutoff frequency of the filter is initially set very low, the input signal will be completely suppressed. However, during the attack phase of the envelope control waveform the cutoff frequency of the filter will rise very rapidly, and the amplitude and harmonic content of the note will both increase as first the fundamental, then

This article continues the discussion of the tone-forming circuits with a description of the Dual VCA module, which can be used in conjunction with the envelope shaper for dynamic control of signal amplitude, and also for periodic amplitude modulation of the signal waveform (tremolo).

C. Chapman

the harmonics, are passed. During the slow decay phase the note will die away slowly as the cutoff frequency falls, starting with the higher harmonics, then the lower harmonics, and finally the fundamental. The variation in turnover frequency of the filter is illustrated in figure 2b.

The tone thus produced is not unlike that of a clavichord, or of a piano which has had drawing pins stuck into the hammers to produce a jangly, honky-tonk effect.

If the same signal and control waveforms are fed to the VCA, the signal amplitude will rise rapidly as the gain increases during the attack phase, and will fall away slowly during the decay phase. However, the harmonic content of the signal will remain unaltered. The sound thus produced is similar to that of percussion instruments such as the piano and xylophone.

By varying the attack and decay times of the envelope shapers a wide variety of tone colour and amplitude dynamics can be produced using the VCF and VCA in conjunction.

VCA design considerations

The dual VCA contains two amplifiers whose gains are independently voltage-controllable, and the design of the VCA poses certain problems, the principal one being that of obtaining adequate dynamic range, as is illustrated in figures 3a to 3d.

Figure 3a shows a control contour from the envelope shaper. At the peak of the control contour the VCA must have a finite maximum gain, which, for the purposes of the discussion, it will be assumed is unity, or 0 dB. At the beginning and end of the note the signal must be inaudible, which means that the gain of the amplifier should ideally be infinitesimally small at these moments in time. In practice, if the gain is around -70 dB then this will be adequate.

What happens if the dynamic range is inadequate is shown in figure 3b. Suppose the gain of the amplifier can be varied by a range of only 40 dB or so, and is set to 0 dB on the peak of the control contour. At the start and end of the note the signal will only be 40 dB

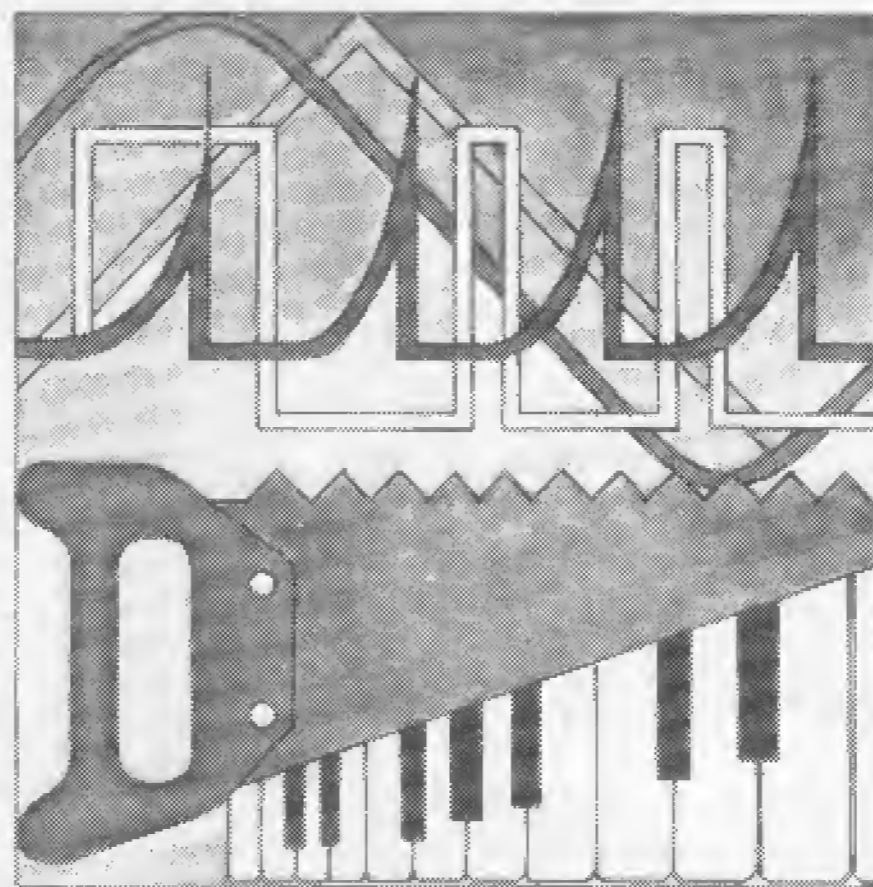

Figure 1. Block diagram illustrating how the VCA fits into the Formant synthesiser system.

Figure 2. Envelope control of the VCF and VCA. The attack-decay contour of figure 2a, when applied to the VCF, varies the turnover frequency of the filter, which provides dynamic alteration in the tone colour of the sound (figure 2b). When applied to the VCA, the envelope contour alters the gain of the VCA, and thus the amplitude of the sound (figure 2c).

down, and if the note is being played fortissimo then this residual signal will still be quite audible.

Another fault of badly-designed VCAs is illustrated in figure 3c. In this example, the VCA cuts off completely below a certain level of control voltage, and so misses part of the attack and decay period of the note. This might be said to be the opposite fault to that of figure 3b, though it is not directly related to dynamic range, but rather to extreme non-linearity of the control characteristic.

Returning to the example of the VCA with only 40 dB dynamic range, if the gain is adjusted so that the signal is inaudible at the beginning and end of the note (i.e. some 70 dB down), it will only be able to increase by 40 dB when the control voltage is applied, instead of the 70 dB required to reach the 0 dB level. The result is an amplitude plateau, as shown in figure 3d.

As mentioned briefly earlier in the article, control of the envelope shaping section of the VCA is carried out exponentially. This is to compensate for the logarithmic loudness response of the human ear. On the other hand control of the periodic amplitude modulation section (tremolo) is linear, since this gives the 'softest' and 'sweetest' sound to the tremolo effect.

Principle of the Formant VCA

The VCA in Formant uses the CA3080 OTA as the controllable amplifier, as in the VCF, and to refresh their memories with regard to the operation of the OTA, readers are referred back to part 6 in the December 1977 issue. The principle of the Formant VCA is illustrated in figure 4. The input voltage U_i is converted to a proportional output current $I_o = g_m \cdot U_i$. However, since we are interested in voltage amplification this output current must be converted into an output voltage, and this is done simply by feeding the current through a load resistor R_L to produce an output voltage $U_o = g_m \cdot U_i \cdot R_L$.

The transconductance of the amplifier, g_m , may of course be varied by a control current I_{ABC} , as explained in part 6, and the gain of the VCA may

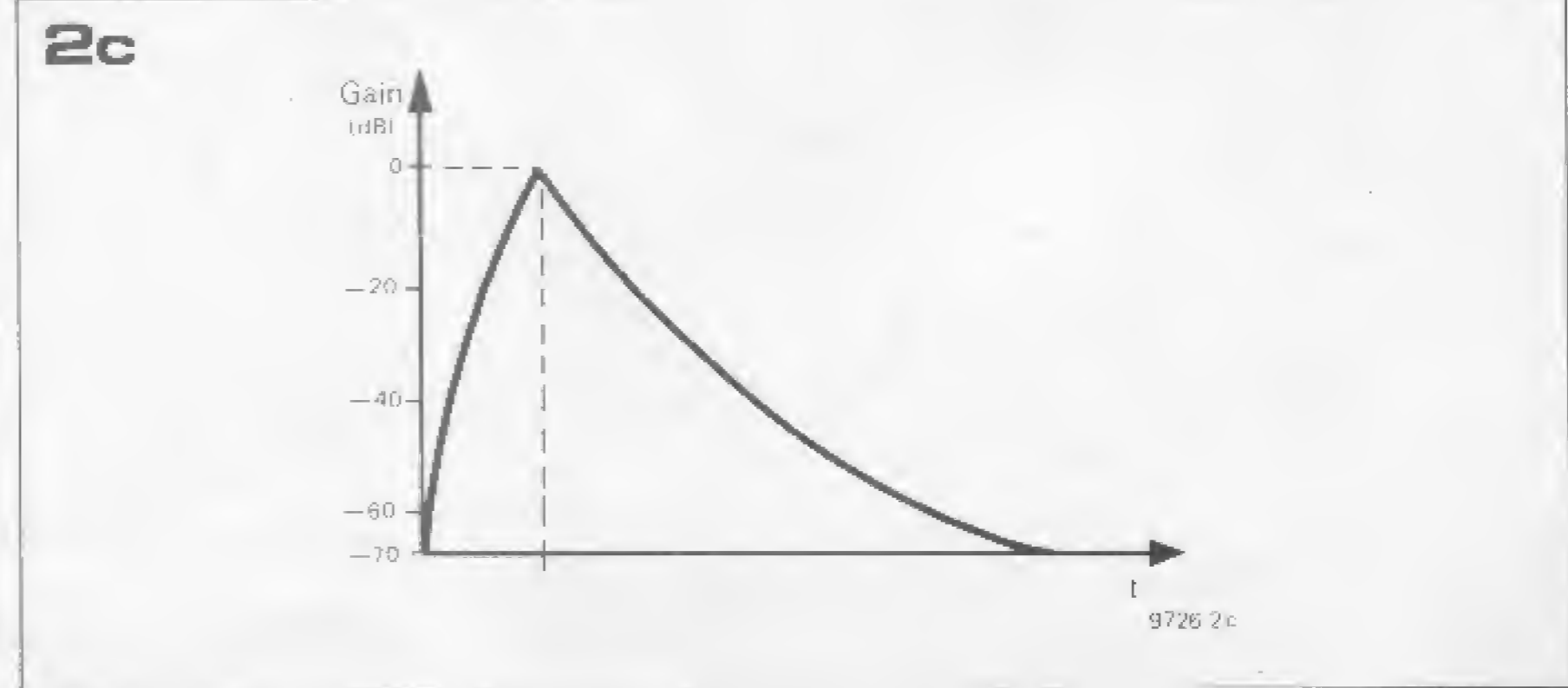
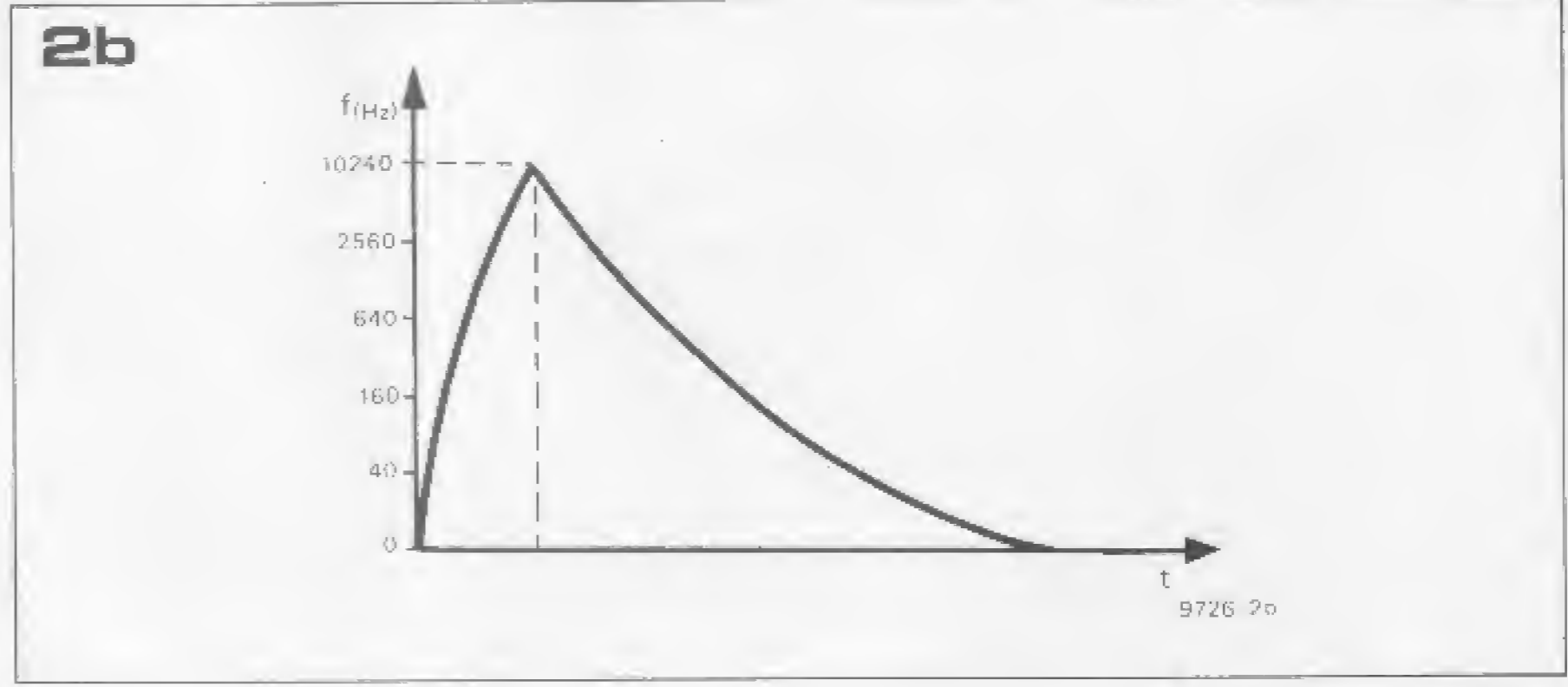
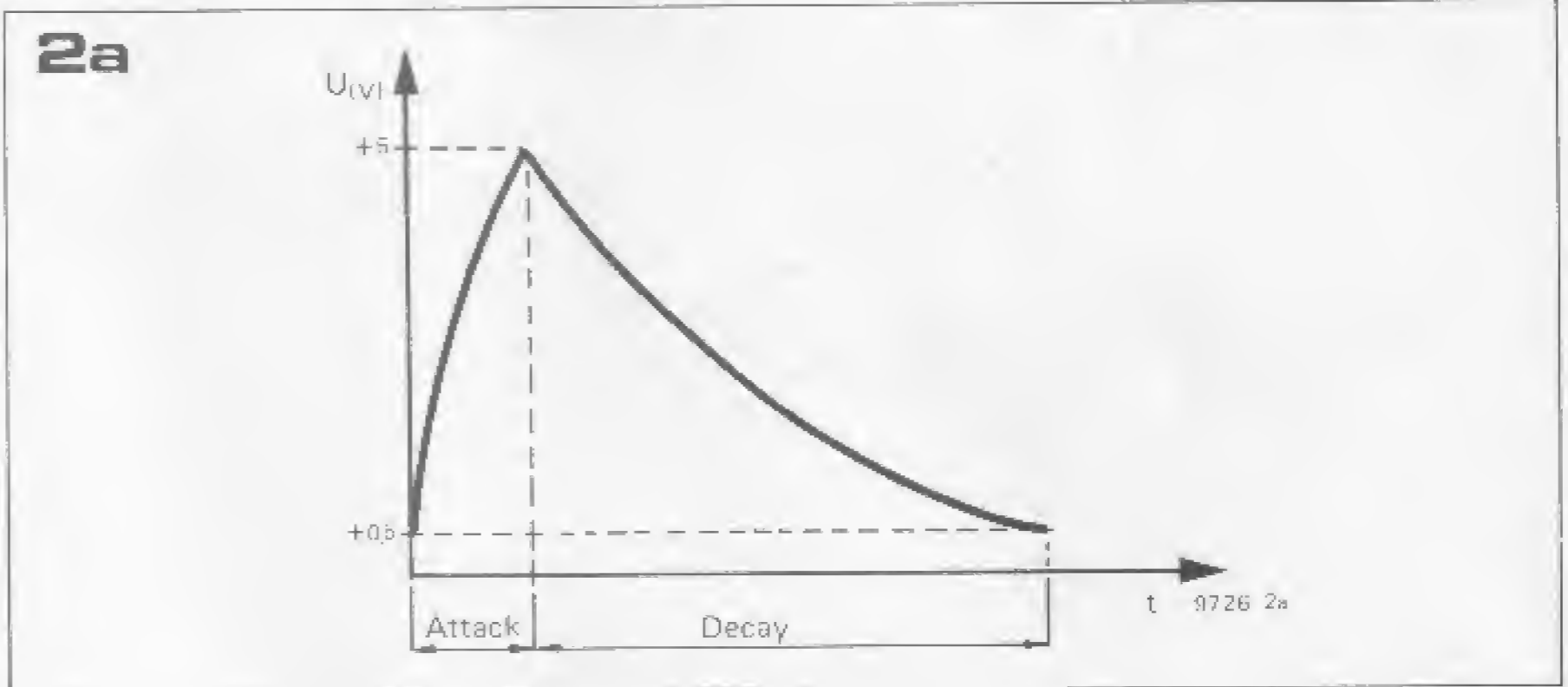
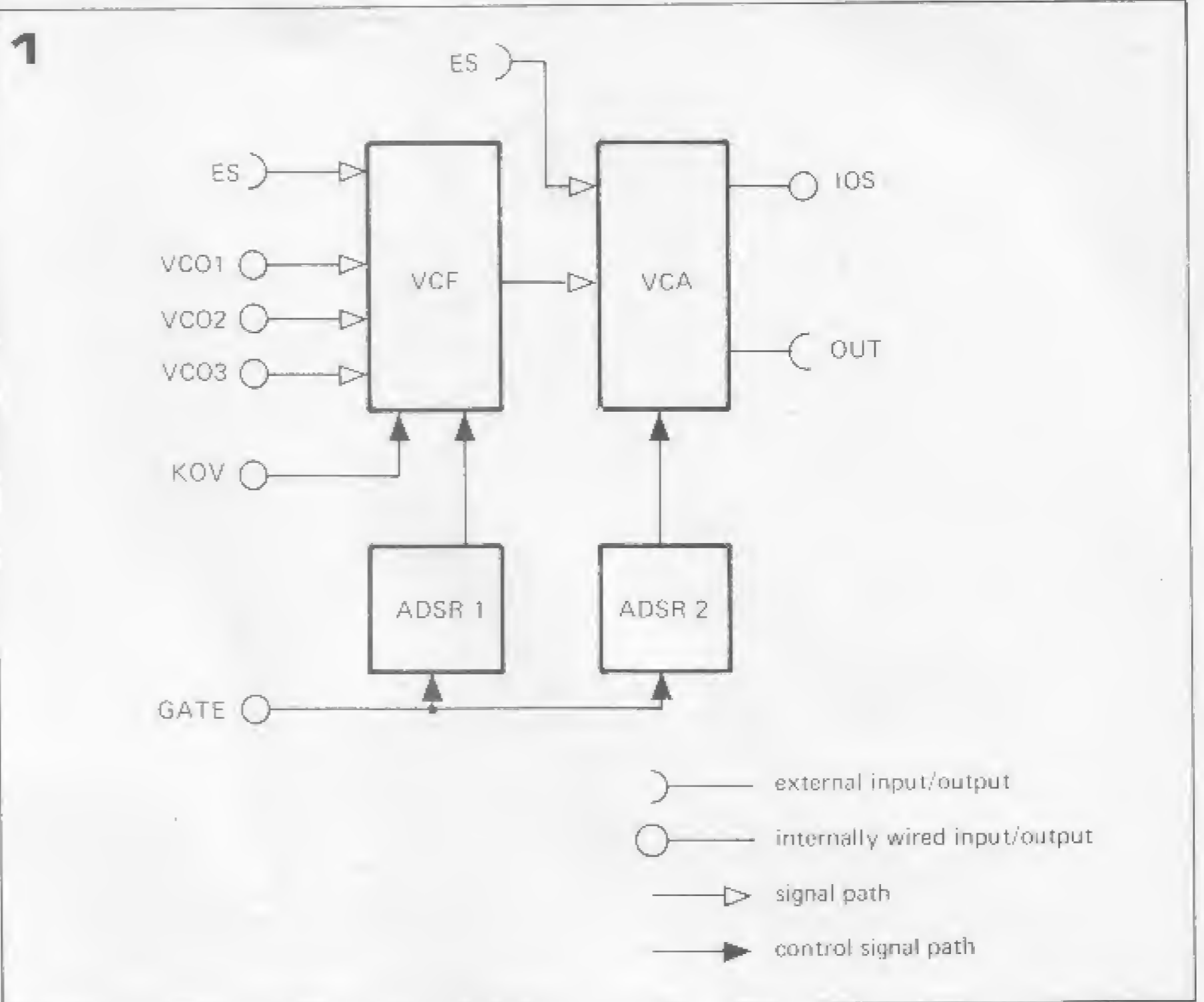

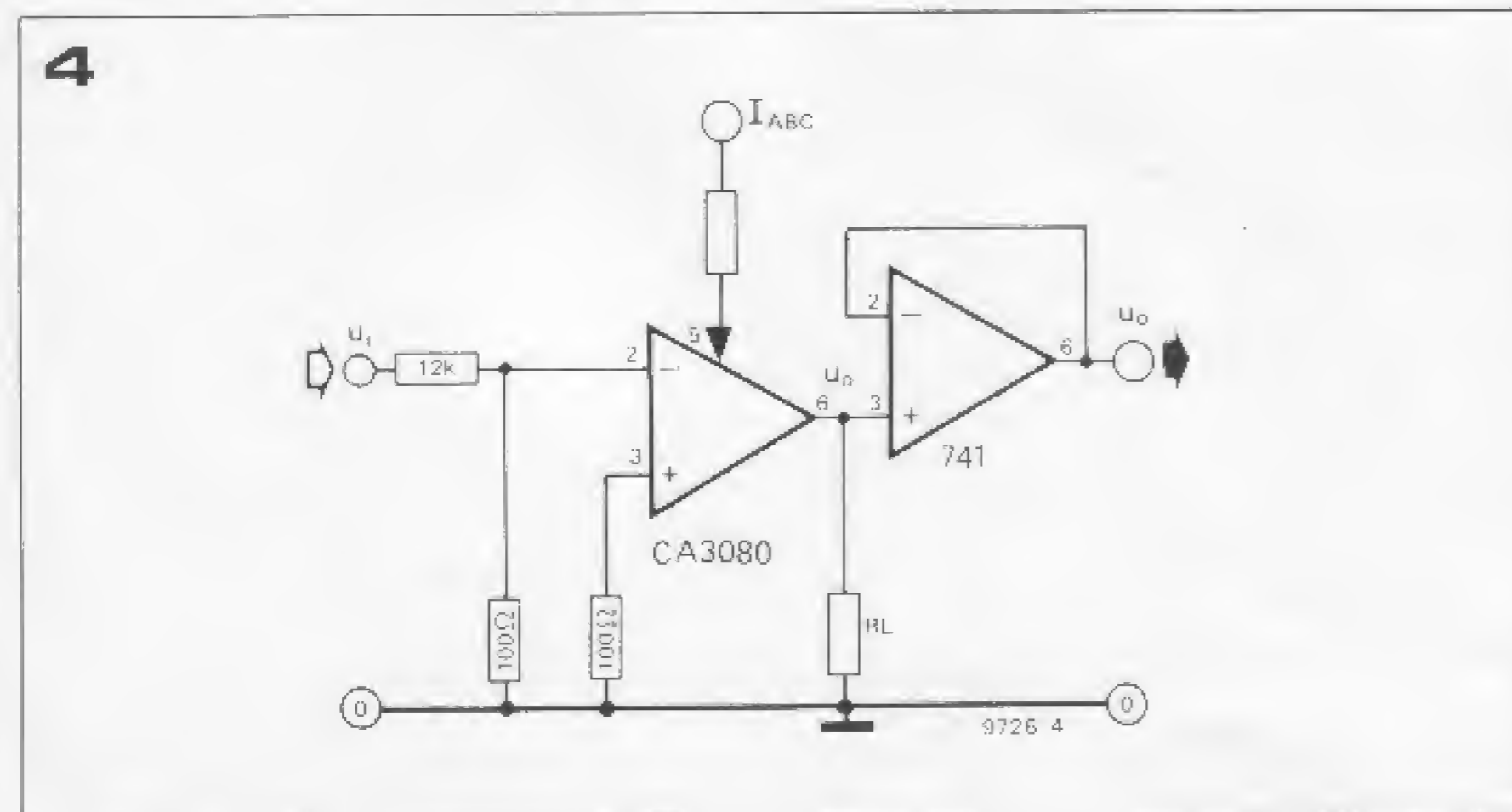
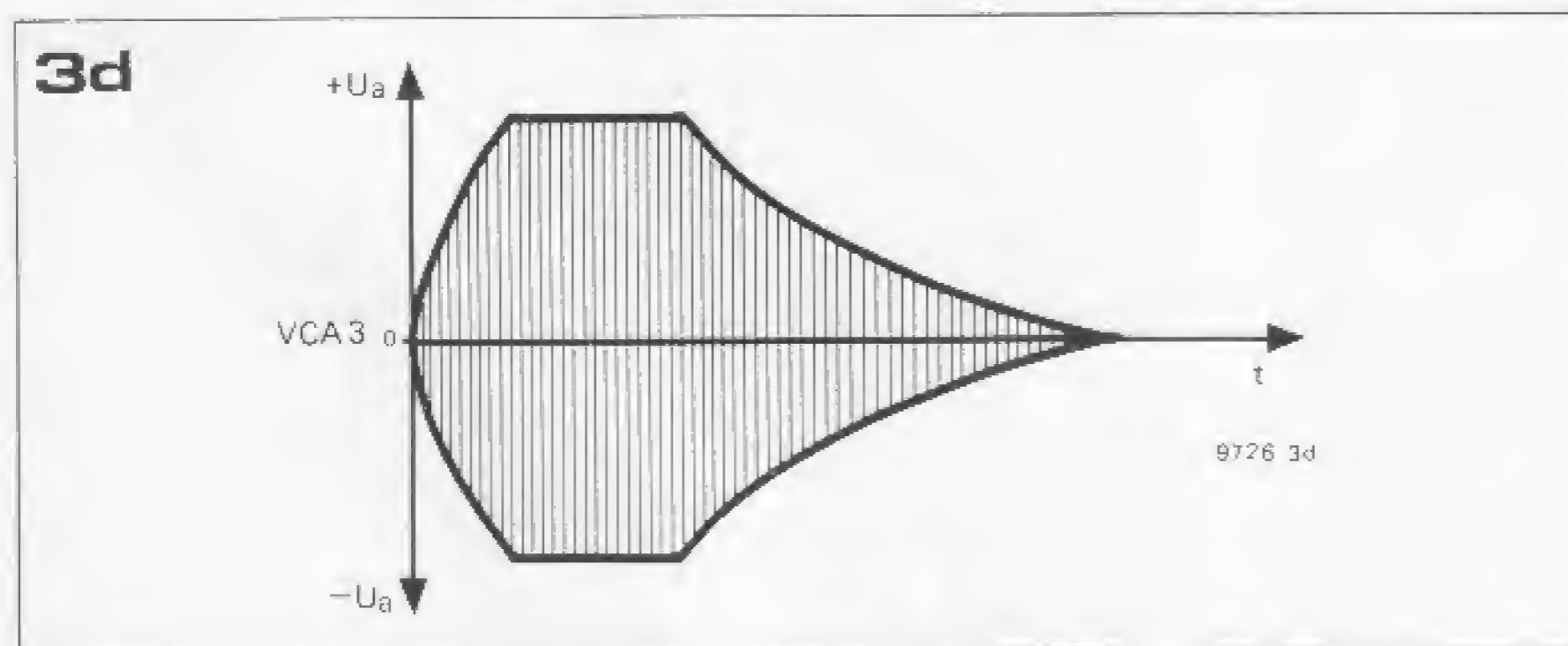
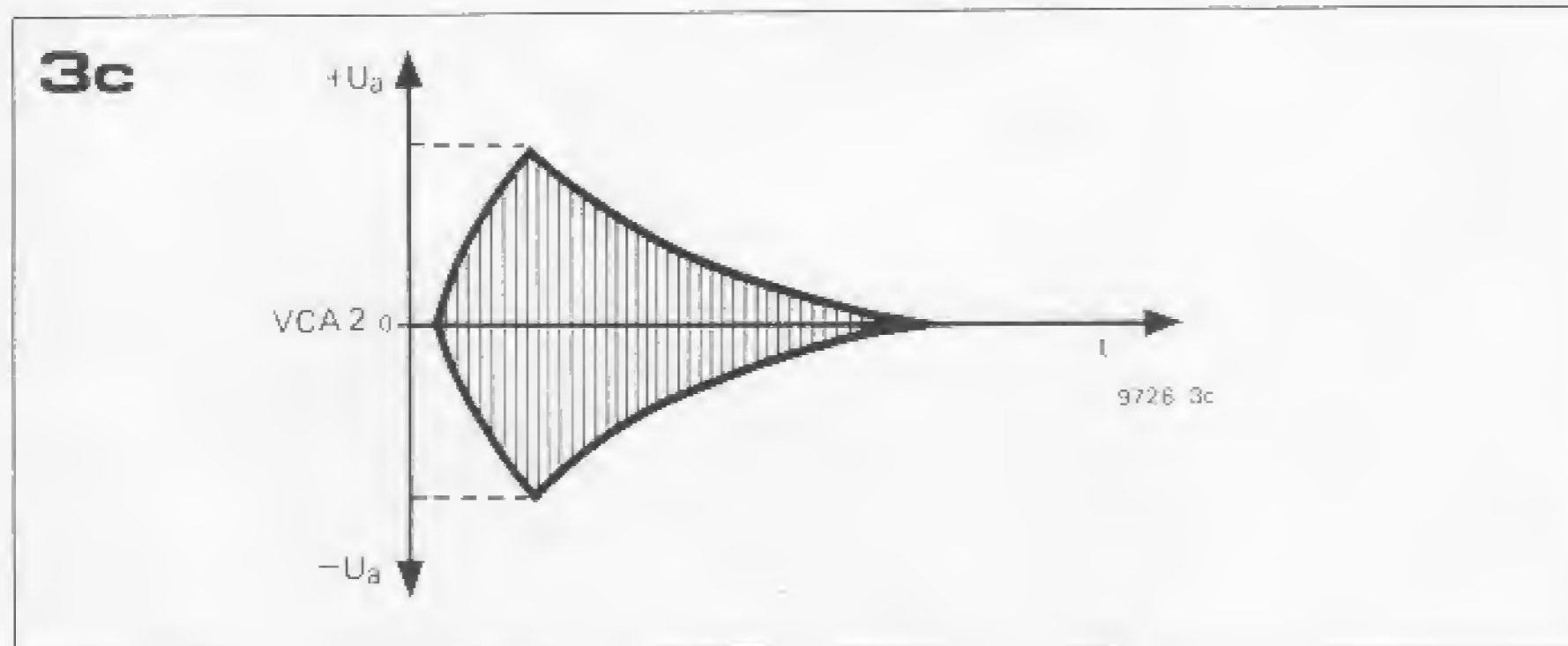
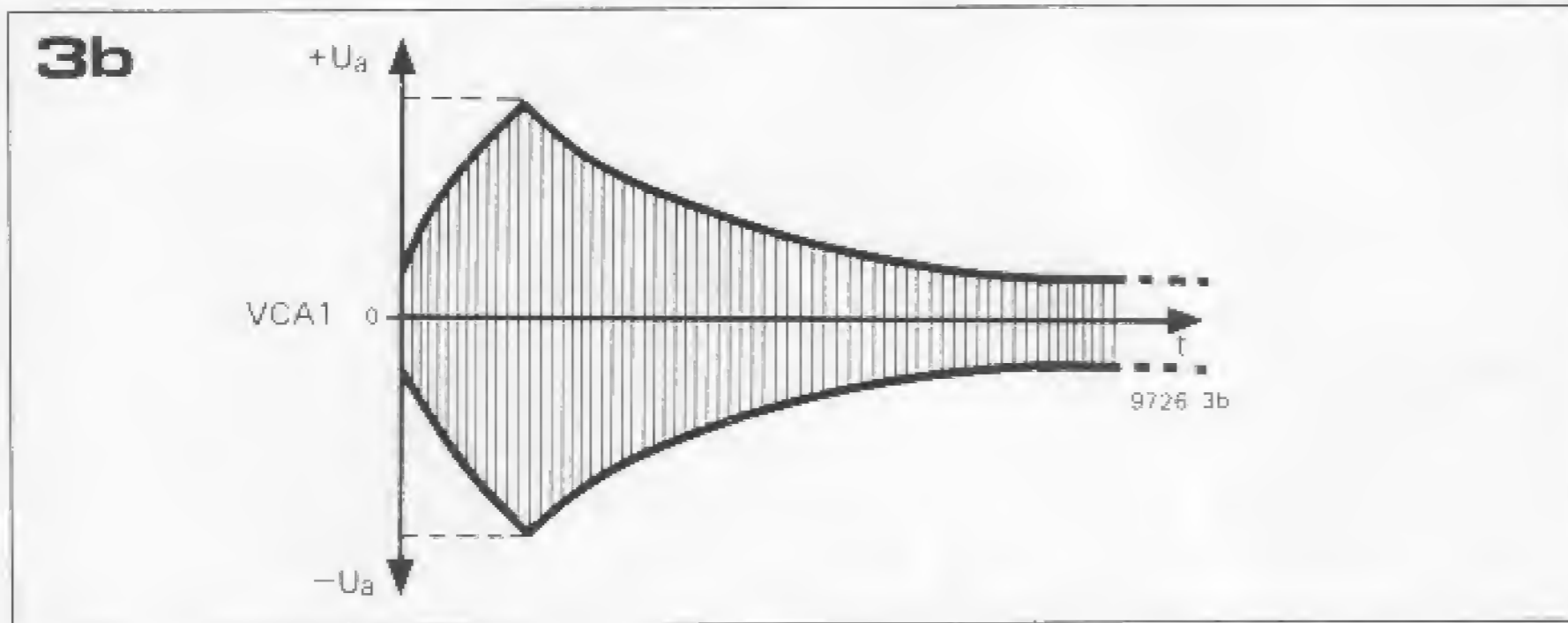
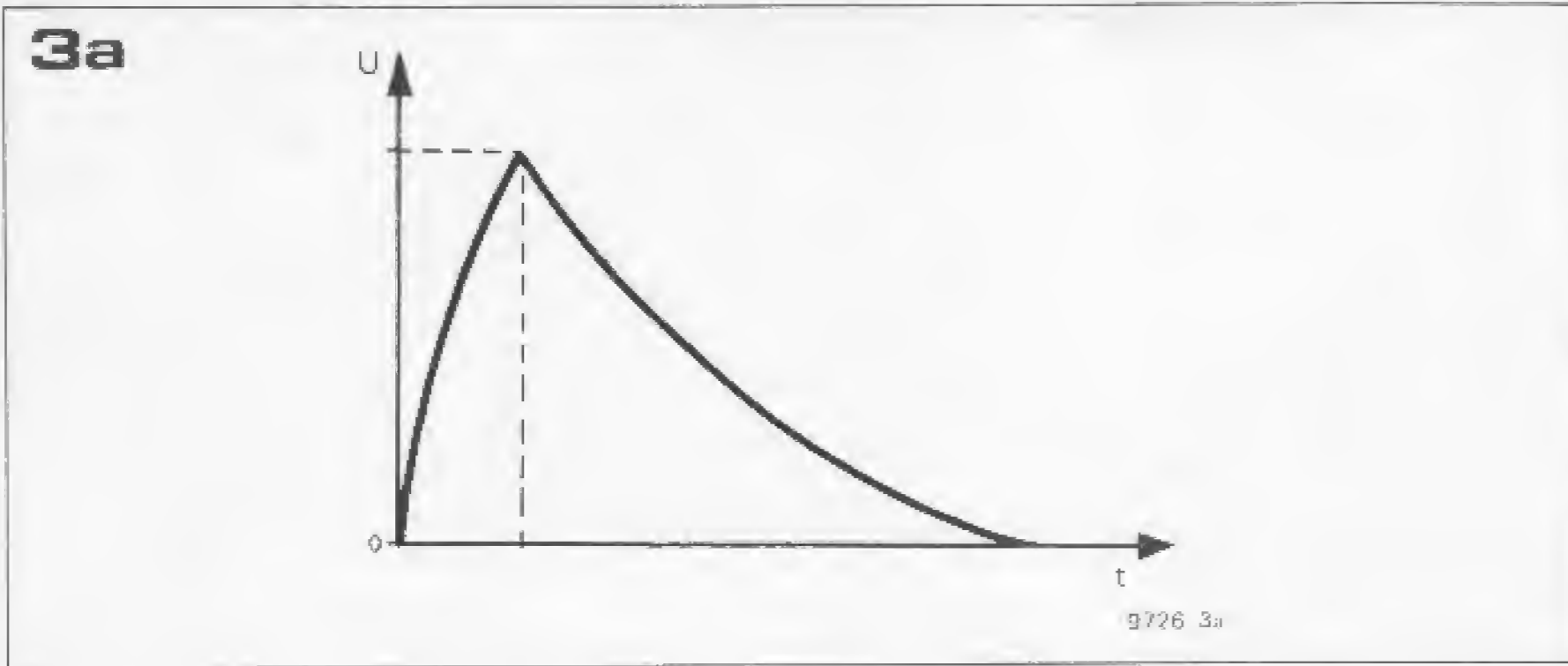

Figures 3a to 3d. Some typical faults of badly-designed or badly-adjusted VCAs are illustrated here. None of the amplitude envelopes in figures 3b to 3d follows the control contour of figure 3a.

In figure 3b there is feedthrough of the signal finishes; in figure 3c the signal is still cut off for some time after the control contour starts, and cuts off again before it finishes; in figure 3d the VCA has insufficient headroom and limits causing a 'plateau' on top of the envelope curve.

Figure 4. The principle of the Formant VCA is illustrated here. The OTA produces an output current proportional to the product of the input voltage and the control current I_{ABC} . This causes a voltage drop across the load resistor R_L , and the output is buffered by an op-amp voltage follower. The input attenuator is necessary to avoid overloading the OTA.

Figure 5. Complete circuit of the Formant Dual VCA. This contains two, cascaded, voltage-controlled amplifiers with independent control inputs; exponential control for envelope shaping and linear control for amplitude modulation (tremolo).

thus be controlled — although at this stage of course it is a CCA!

The output of the OTA may not drive any external load in addition to R_L , as this would lower the load impedance and alter the gain, so the output of the OTA is connected to a voltage follower/buffer with a high input impedance.

Both sections of the VCA operate on the same principle. However, only the output of the second OTA is buffered, since it is this output that is connected to any external loads. As the output of the first OTA has no external connection it is simply connected to the input of the second OTA.

The OTA has one disadvantage that cannot be ignored. As mentioned last month, its linearity is good only for small input signals (typically ± 10 mV) which is why a large degree of input signal attenuation is required. This means that the signal-to-noise ratio is not exceptionally good, and for this reason it is best to use the VCA with the largest possible input signal consistent with low distortion. A modulation indicator is provided, which allows the best compromise to be obtained between excessive noise, at low input levels, and distortion at high input levels.

5

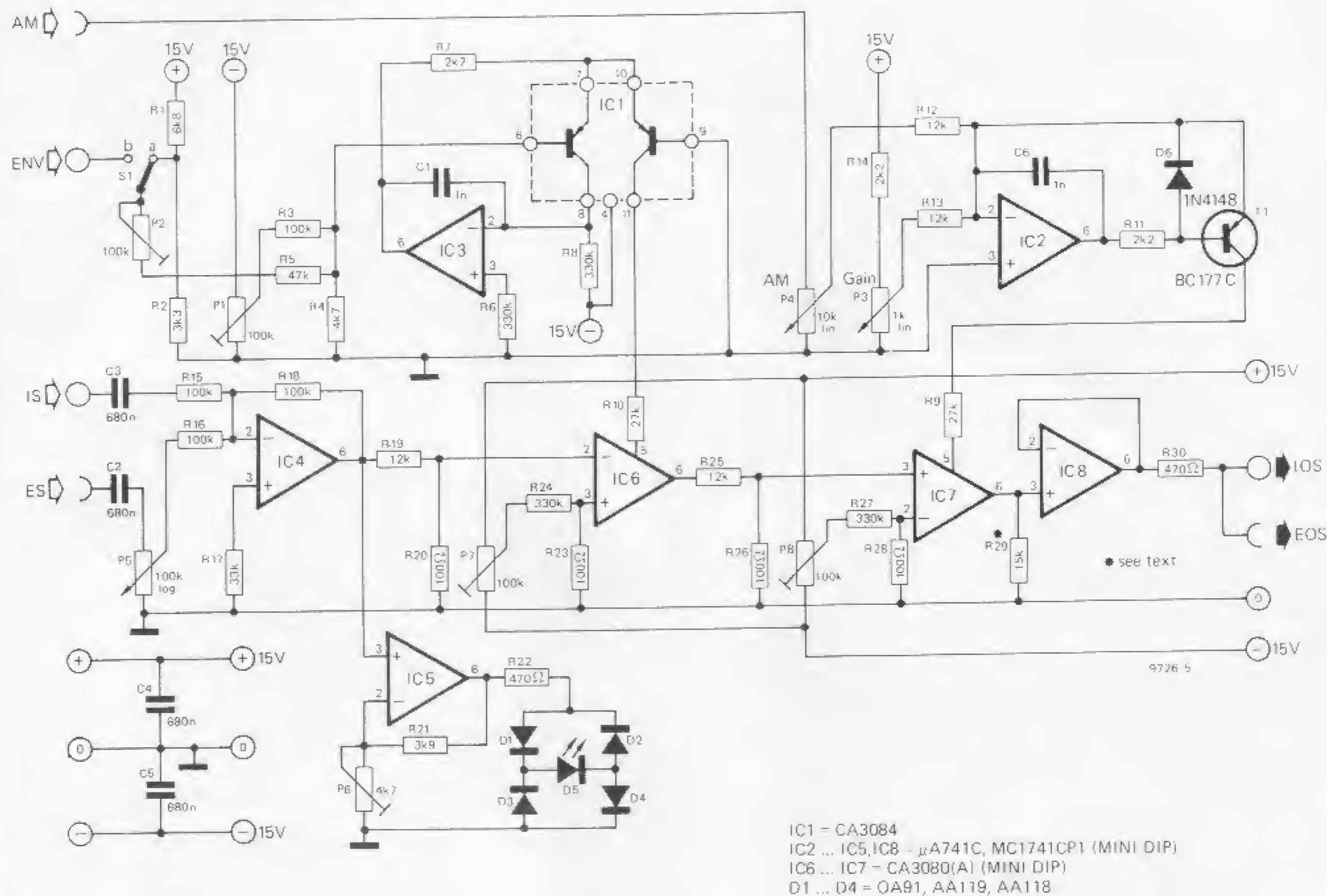

Circuit of the VCA

The complete circuit of the VCA is given in figure 5. The exponential converter built around IC1 and IC3 will immediately be recognised, since it is very similar to that used in the VCF. The input configuration, however, is much simpler, there being but one external input, ENV, from the envelope shaper. If required this can be switched out by setting S1 in position 'a', in which case a fixed gain results. The gain/control voltage characteristic of the VCF is roughly 12 dB/volt, but as the use of the word 'roughly' suggests, the accuracy of this characteristic is relatively unimportant, unlike the octave/volt characteristics of the VCO and VCF. The ear is much less critical of amplitude errors than it is of frequency errors. The dB/volt characteristic of the VCA may be adjusted by P2, whilst P1 is an offset trimmer. The output current of the exponential converter controls the gain of the first OTA, IC6. The linear voltage-current converter is constructed around IC2, which is connected as an inverting, summing amplifier. An input signal may be fed to P4 via the AM input socket, and a DC input voltage is available from P3 ('Gain'). Both these input voltages cause

proportional currents to flow through R12 and R13, and since these currents cannot flow into the inverting input of the op-amp they flow round the feedback loop through T1, and into the control input of IC7. The audio signal to the VCA comes either from the permanently wired internal signal input (IS) or from the external signal socket (ES) on the front panel of the VCA module. The amplitude of the external input signal is controlled by P5, whereas the amplitude of the internal signal is controlled at the IOS output of the VCF, by P6 of the VCF module. IC4 functions as a summing amplifier with a gain of -1, and the signal level at the output of IC4 is monitored by the modulation indicator constructed around IC5. This is a non-inverting amplifier feeding a bridge rectifier D1 to D4, the output of which drives the modulation indicator LED D5. Once the peak signal level at the output of IC5 exceeds the combined knee voltages of D1 plus D5 plus D4 (or D3 plus D5 plus D2) then the LED will start to glow and will glow brighter as the signal level increases. P6 is used to adjust the gain of IC5 so that D5 starts to glow at the signal level where overmodulation

begins to occur. The output signal from IC4 is attenuated by R19 and R20 down to a level which the OTA, IC6, can handle. The output of the exponentially controlled OTA, IC6, is fed via a second attenuator R25/R26, to the input of the linearly-controlled OTA, IC7. The output of IC7 is buffered by voltage-follower IC8 and two outputs from the VCA are provided, an internally wired output, IOS, and an output to a front panel socket, EOS. Potentiometers P7 and P8 are provided for trimming the offset voltages of IC6 and IC7.

Construction

The comments with regard to component quality that have been made in previous articles apply equally to the construction of the VCA, and will not be repeated. A printed circuit board and component layout for the VCA are given in figure 6, and a front panel layout is given in figure 7. Observant readers may notice that the original concept illustrated in E24 (April 1977) called for a large (6 U) front panel for the VCA, whereas a small (3 U) panel is shown in figure 7. There are several reasons for this change.

In the first place, the number of controls required fit easily on a small panel, and it's cheaper; secondly, standard 19" racks will fit 6 panels side-by-side (as shown in part 3, figure 15) so there is sufficient space; finally, two further large-size modules are now planned: a 24 dB/oct VCF and a dual resonant filter module. This means that the 'basic synthesizer concept' now calls for 6 small front panels (2 x ADSR, DUAL VCA, LFO's NOISE and COM; 'COM' stands for Control and Output Module, and it replaces the 'power' module shown in the original concept) and 6 large panels (3 x VCO, VCF, 24 dB/oct VCF and dual resonant filter).

Testing and adjustment

For optimum performance the VCA must be matched to a particular envelope shaper, and thereafter the VCA and envelope shaper should be used as a pair. This is not necessary in the case of the VCF, which may be used with any envelope shaper.

To test and adjust the VCA, the completed keyboard and interface receiver must be available, together with VCOs, VCF and the envelope shaper to which the VCA is to be matched. The IOS output of the VCO is connected to one of the VCO inputs of the VCF, and the IOS output of the VCF is connected to the IS input of the VCA. The GATE output of the interface receiver is connected to the GATE input of the envelope shaper and output ENV of the envelope shaper is connected to input ENV of the VCA.

For the initial test, the sawtooth output of the VCO is selected and the output level is set to maximum. The VCF is set to the lowpass mode, but the turnover frequency is set to maximum by turning the octaves control fully clockwise. The Q control is set to minimum, the KOV input is switched off and the output level is set to maximum.

- At the IOS output of the VCF, the sawtooth signal from the VCO should now be available in phase with, and at the same amplitude as, the VCO output (about 2.5 V p-p).
- At the output of IC4 of the VCA, the signal should be available at the same level, but inverted.
- With S1 of the VCA in position 'a' (ENV input switched off) and P7 and P8 in mid-position, the sawtooth signal should be available at the output of IC6 in phase with the VCO output, and the amplitude should be adjustable by P1.
- At the output of IC7 the signal should again be in phase, and both P1 and P3 should vary the amplitude.
- Finally, the signal should be available at outputs IOS and EOS.

This concludes the basic functional check of the VCA, and the adjustment procedure can now be carried out.

Modulation Indicator

Using the same input signal, P6 is

adjusted until the modulation indicator D5 just begins to glow. Increase the signal amplitude by switching in the second and third VCOs, when the LED should glow brighter.

After this test, the second and third VCOs should be switched off again.

Offset adjustment

Turn the output level of the VCF to zero and short the IS input of the VCA to ground. Set S1 of the envelope shaper to 'AD' and the A, D, S and R controls to minimum (shortest attack and decay, and 0% sustain). Turn P5 of the VCA fully anticlockwise, set S1 of the VCA to position 'b' (ENV) and observe the DC output voltage of IC6 on an oscilloscope.

When a key is depressed, a step output voltage will be observed at the output of IC6. This is the offset voltage of the IC, which is amplified as the gain of IC6 increases under the influence of the envelope control voltage; if it is not nulled out then it will break through to the output as 'cracks' or 'plops'. P7 is adjusted until the step voltage is as small as possible on the most sensitive range of the oscilloscope.

The offset nulling procedure must then be repeated for IC7. S1 is switched to the 'off' position, P3 is turned fully anti-clockwise and the external output of the envelope shaper is connected to the AM input of the VCA. The IOS output of the VCA is monitored on the oscilloscope and the offset nulling procedure is repeated, this time using P8.

Adjustment of exponential gain control

The exponential converter must be adjusted so that the required gain control range of IC6 is obtained from the +0.5 V to +5 V range of the envelope shaper.

S1 of the envelope shaper is set to the 'AD' position and fairly short attack and decay times are selected. The short circuit across the VCA input is removed, the VCF level control is turned to maximum and a signal is fed in from one of the VCOs. P2 on the VCA board is initially set to its mid-position.

The output of IC6 is now monitored with an oscilloscope and a key is repeatedly depressed, when AD envelope curves should be seen. P1 is then adjusted for minimum feed through when the key is not depressed, less than one or two millivolts will be acceptable. The Y sensitivity of the oscilloscope is now adjusted so that the entire envelope curve can be seen when a key is depressed. P2 should then be adjusted until a good attack/decay curve without limiting (seen as a flat top or plateau as shown in figure 3d) is just obtained. Since P1 and P2 interact to some extent, it may be necessary to repeat the adjustment procedure several times to obtain the best results.

Adjustment of overall gain

The overall gain of the VCA should be 0 dB (unity) at maximum modulation

Parts list for figures 5 and 6

Resistors:

R1 = 6k8
 R2 = 3k3
 R3,R15,R16,R18 = 100 k
 R4 = 4k7
 R5 = 47 k
 R6,R8,R24,R27 = 330 k
 R7,R11,R14 = 2k2
 R9,R10 = 27 k
 R12,R13,R19,R25 = 12 k
 R17 = 33 k
 R20,R23,R26,R28 = 100 Ω
 R21 = 3k9
 R22,R30 = 470 Ω
 R29 = 15 k (nominal value, see text)

Potentiometers:

P1,P2,P7,P8 = 100 k preset
 P3 = 1 k lin.
 P4 = 10 k lin.
 P5 = 100 k log.
 P6 = 4k7 (5 k) preset

Capacitors:

C1,C6 = 1 n
 C2,C3,C4,C5 = 680 n

Semiconductors:

IC1 = CA 3084 (DIL package)
 IC2,IC3,IC4,IC5, IC8 = μA 741C,
 MC 1741 CP1 (Mini DIP)
 IC6,IC7 = CA 3080 (A)
 T1 = BC 177B, BC 178C, BC 179C,
 BC 557B, BC 558C, BC 559C
 D1 . . . D4 = DUG (OA91,
 AA118, AA119)
 D5 = LED (TIL 209 or similar)
 D6 = 1N4148

Miscellaneous:

31-way Euro connector
 (DIN 41617)
 S1 = SPST miniature toggle
 switch
 3 off, 3.5 mm jack socket
 3 off, 13-15 mm collet knobs with
 pointer

Figure 6 Printed circuit board and component layout for the VCA (EPS 9726-1).

6

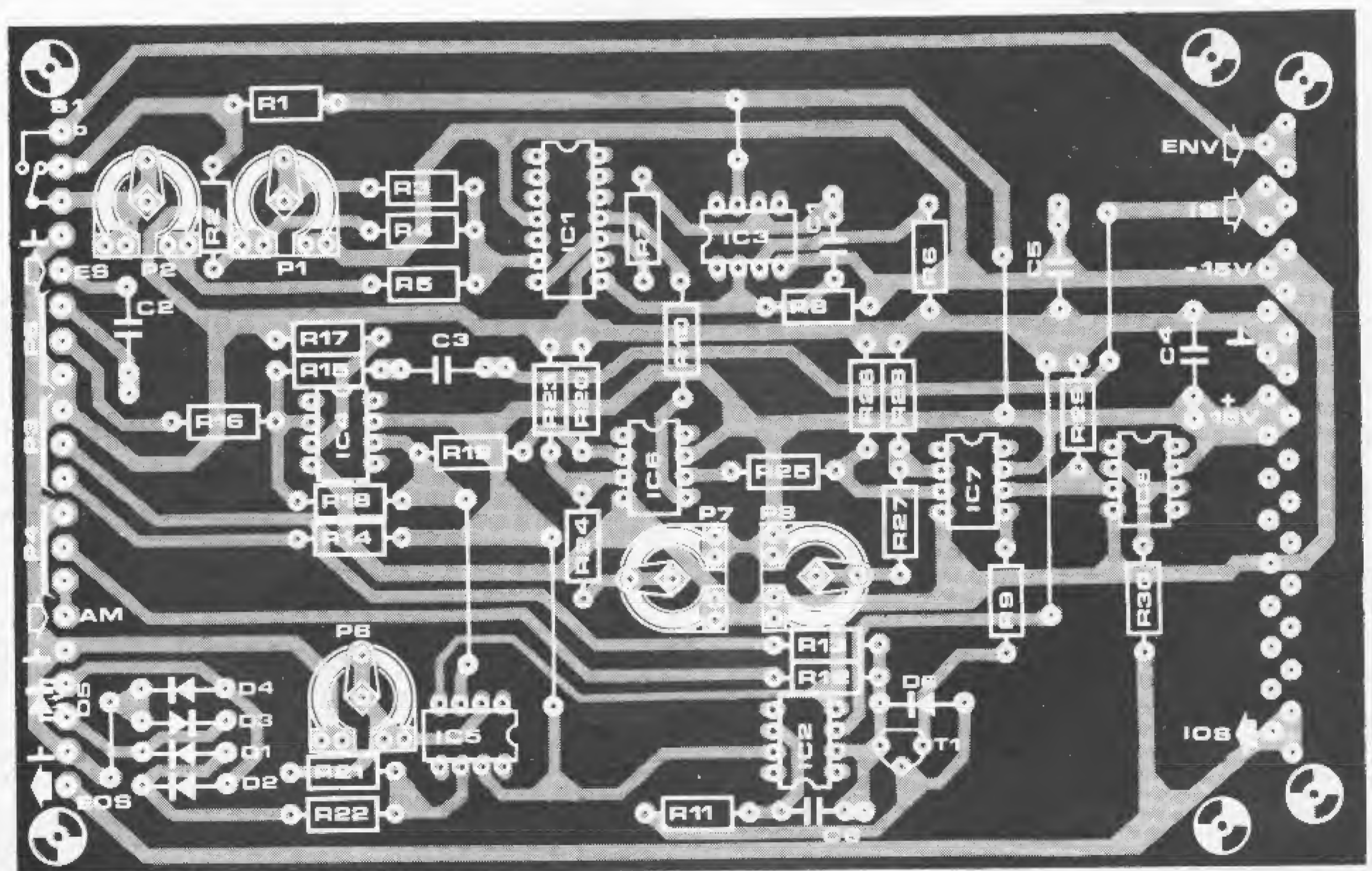
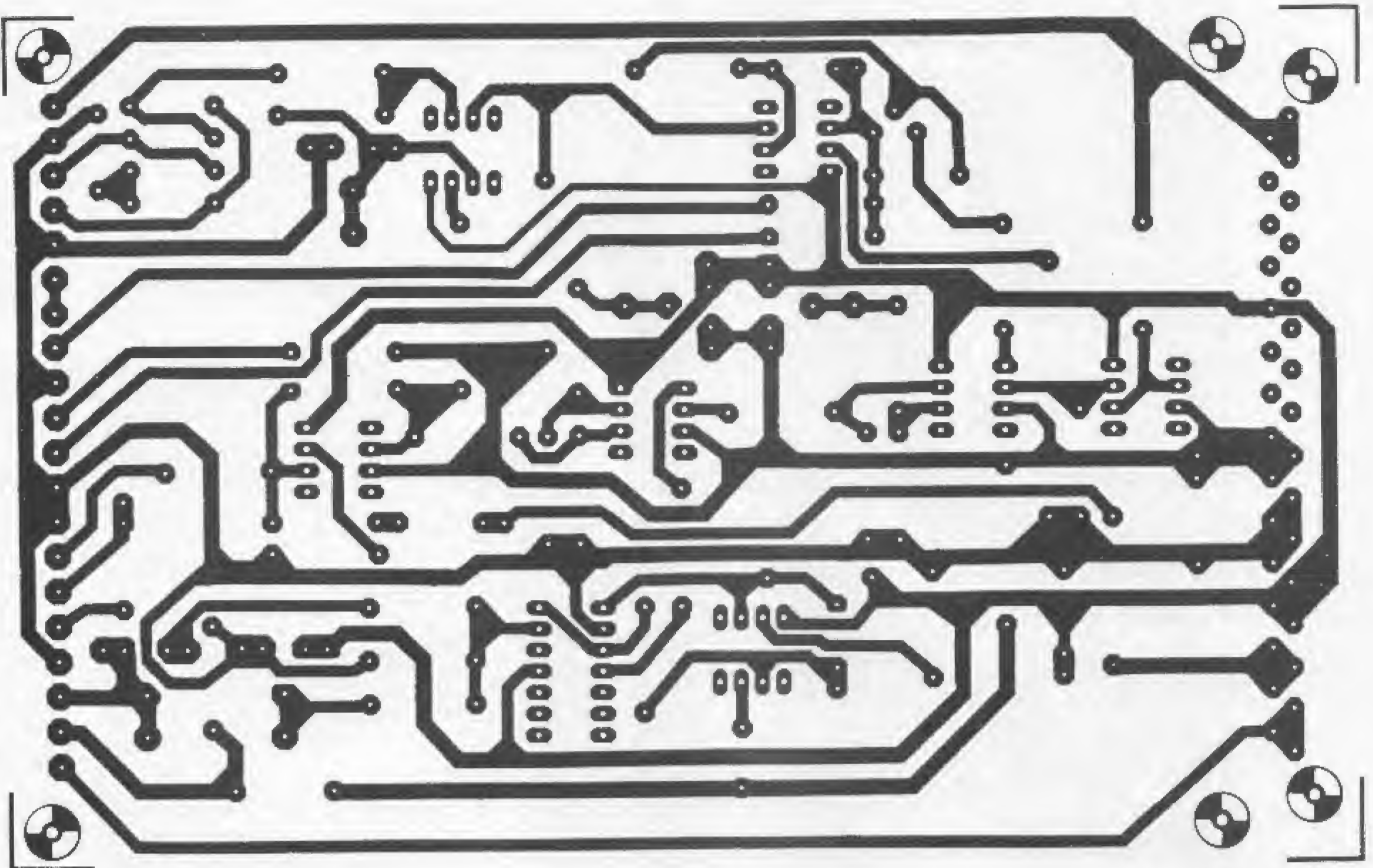

7

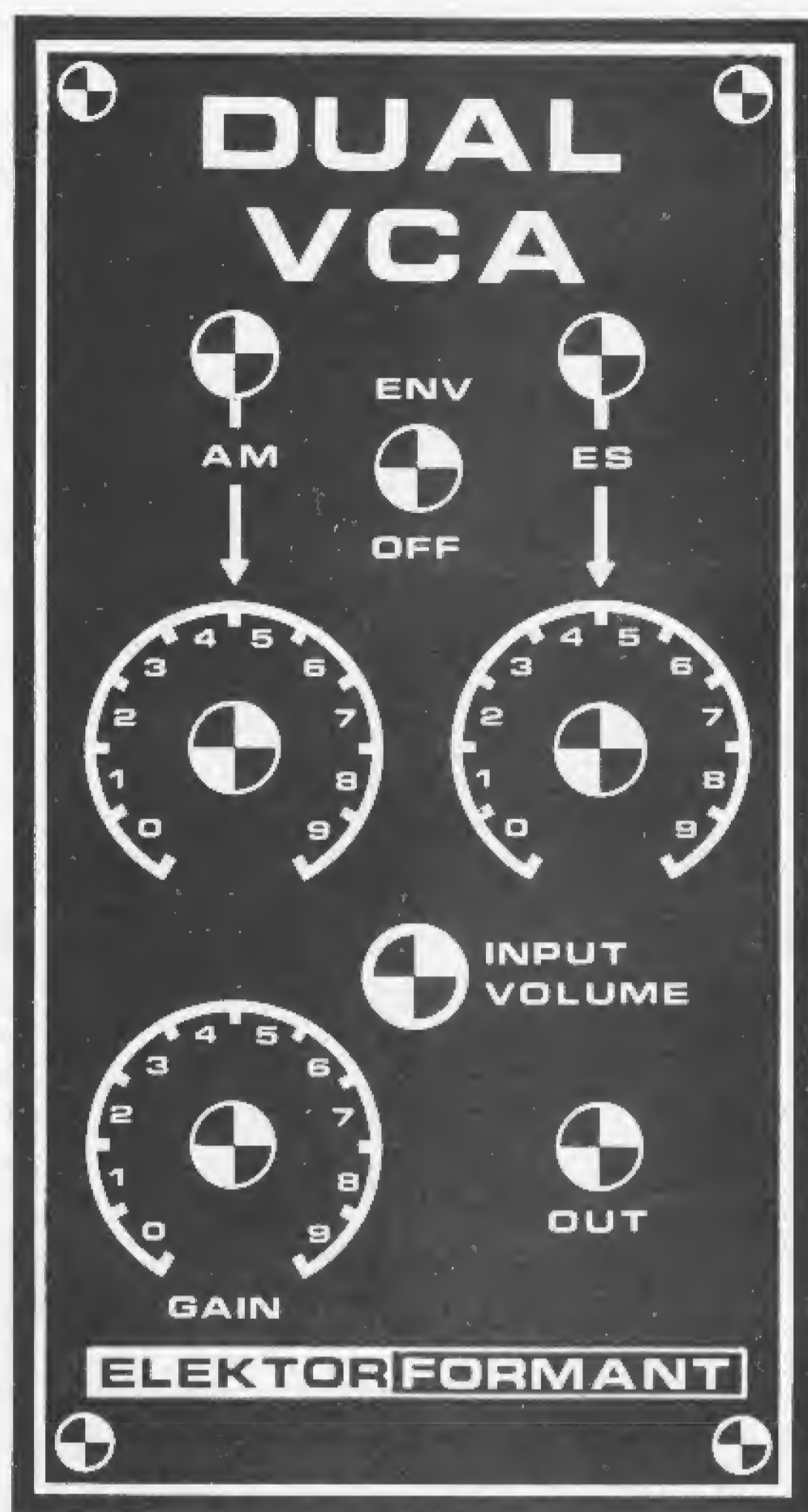

Figure 7 Front panel layout of the VCA. S1 is located between the AM and ES input sockets. Immediately below these sockets are the respective input level controls: P4 sets the AM modulation depth and P5 is the external input level control. Below these again are the modulation indicator (D5), the manual gain control (P3) and the output socket (EOS).

of IC6 and IC7. To achieve this it may be necessary to alter the value of R29, which is nominally 15 k. Set the gain control P3 to maximum, and the envelope shaper to the 'ADSR' mode with 100% sustain. A key is now depressed and held down, and the output level of the VCA (at IOS or EOS) is compared with the input level at IS. These levels should be the same; if the output level is too low, then R29 must be increased in value, and if the output level is too high then R29 must be reduced. A 3 dB difference ($\times 0.707$ or $\times 1.414$) between the input and output levels is acceptable.

This completes the adjustment of the VCA.

Use of the VCA

The input signal level to the internal input of the VCA is controlled by the output potentiometer of the VCF. In normal use this control should be adjusted so that the LED just begins to glow, which occurs at a nominal level of 2.5 V p-p with one VCO input signal, less if more than one VCO is connected. If the LED glows brightly, then the VCA is being overmodulated and distortion may occur. This is not to say that this should never be allowed to

happen, since the deliberate introduction of distortion can be used to produce 'fuzz' effects. If the LED does not glow, then this indicates undermodulation and the possibility of a poor signal-to-noise ratio.

Tremolo

To produce tremolo effects a low-frequency oscillator signal (LFO) can be fed into the AM input socket. The Formant LFOs, described later in the series, have an output voltage swing of ± 2.5 V, and if the GAIN potentiometer P3 is set in its mid-position this will give a modulation depth of 100%. Reducing the LFO input signal by means of the AM potentiometer P4 allows the modulation depth to be varied down to 0%.

Expression Pedal

An expression pedal may also be connected to the AM input. This can be a pedal fitted with a logarithmic potentiometer and battery, whose output can be varied from zero to about +5 V with the pedal fully depressed.

Tuning

The ENV/OFF switch S1 is particularly useful when tuning the synthesiser,

since it allows signals to pass continuously through the VCA, unaffected by the envelope shaper when in the OFF position.

Outputs

The external output of the VCA has an impedance of about 500 Ω , and this output may be fed to other equipment such as tape decks and external amplifiers, or to high impedance headphones for monitoring.

The internal output signal (IOS) is taken to the Formant amplifier module, which will be described later in the series. This is fitted with tone and volume controls and a small power amplifier for monitoring purposes. It will drive low impedance headphones and loudspeakers, and can also be used to drive spring line reverberation units or other external equipment. **M**

Missing link

In part 6 (VCF), the value of R18 is shown as 22 k. The author now suggests that increasing the value to 27 k will give the Q-control a slightly more musically-useful range.

slow on/off

The block diagram of figure 1 illustrates the principle of operation. If the circuit is to be controlled by some other electrical or electronic circuit (for example a time switch) then the opto-isolator (A) should be included for safety reasons, as the slow on/off fader circuit is connected direct to the mains supply. If the circuit is to be controlled manually then the opto-isolator may be omitted and a (well-insulated) push-button used. These options will be discussed in more detail in the description of the complete circuit, but for the moment the pushbutton input will be referred to. Pressing the pushbutton causes a pulse generator (B) to clock flip-flop FF. If the Q output of the flip-flop is initially low then clocking it will make the Q output high.

The Q output voltage is fed to an integrator (D), the output of which ramps positive. This slowly rising DC voltage is fed to the control input of a TCA 280 IC, which is a triac control circuit. The output of the TCA 280 is used to trigger a triac, which in turn controls the lamp. As the integrator output voltage slowly rises the brightness of the lamp will decrease.

If the pushbutton is again pressed, the clock pulse so generated will cause the flip-flop to return to the reset condition (Q output low). The integrator output voltage will slowly fall and the lamp will brighten.

Complete circuit

The circuit is shown in two sections; figure 2a shows the circuitry for generating the control voltage, whilst figure 2b shows the TCA 280 and its associated components, together with a stabilised power supply for the control circuit.

Assuming that the circuit is originally in the 'on' condition, the Q output of flip-flop IC1 will be low, the output of op-amp IC2 will be low, and C2 will be discharged. When the LED in the opto-isolator is lit by passing current through it, the emitted light falls on the photo-transistor, causing it to turn on. This turns on T1, applying a positive-going step to the clock input of IC1, which causes the Q output to go high. The

In order to provide the optimum conditions for tropical birds and fish in northern climes, artificial lighting is frequently used to extend the hours of 'daylight' during the winter months.

However, to avoid confusing the animals it is important to simulate sunrise and sunset by slowly fading the lighting up and down rather than switching it on and off abruptly. The slow on/off fader circuit described in this article will do just this, and can also be used for many other applications. For example, when leaving a room at night it is useful to be able to leave the lighting to fade down slowly to avoid having to make an exit in the dark.

circuit can also be clocked by a push-button connected between points A and B.

A novel trick is used to make C2 charge very slowly. Rather than charge it direct from the Q output of IC1 through a resistor, it is charged from the junction of R4 and R5 through P3. With P3 at maximum and the output of IC2 at 0 V, this means that the initial charging current is only 100 nA! To achieve this by charging from the Q output of IC1 via a single resistor would call for a resistance of 100 M Ω . As the voltage across C2 slowly rises, so does the output voltage of IC2, which is connected as a voltage follower. The voltage at the junction of R4 and R5 therefore also rises, so that the voltage applied to P3 is always slightly above the voltage on C2 and a small charging current flows into this capacitor.

When the flip-flop, IC1, is reset by the pushbutton or by the opto-isolator, C2 discharges, and the output of IC2 falls.

The maximum and minimum brightness of the lamp is determined by the minimum and maximum output voltage of IC2. The maximum output voltage is set by adjusting P1 to limit the maximum voltage to which C2 can charge. Similarly, the minimum output voltage is set by adjusting P2 to limit the minimum voltage to which C2 can discharge.

The control voltage from the output of IC2 is fed to pin 5 of the TCA 280 (figure 2b). Basically this IC generates a sawtooth signal that is synchronous with the mains waveform. (See figure 2c). The sawtooth is fed to one input of a voltage comparator, the DC control voltage being fed to the other input as a reference. The output of the comparator is processed and used to generate trigger pulses for the triac.

The magnitude of the DC control voltage determines the point on the sawtooth (and hence on the mains waveform) at which the comparator output changes state, and therefore the point at which the triac triggers. The final result is that the lamp brightness varies with the control voltage. IC3 derives its DC supply from the mains via diode D3 and dropper resistor R6. Since most of the mains voltage is dropped



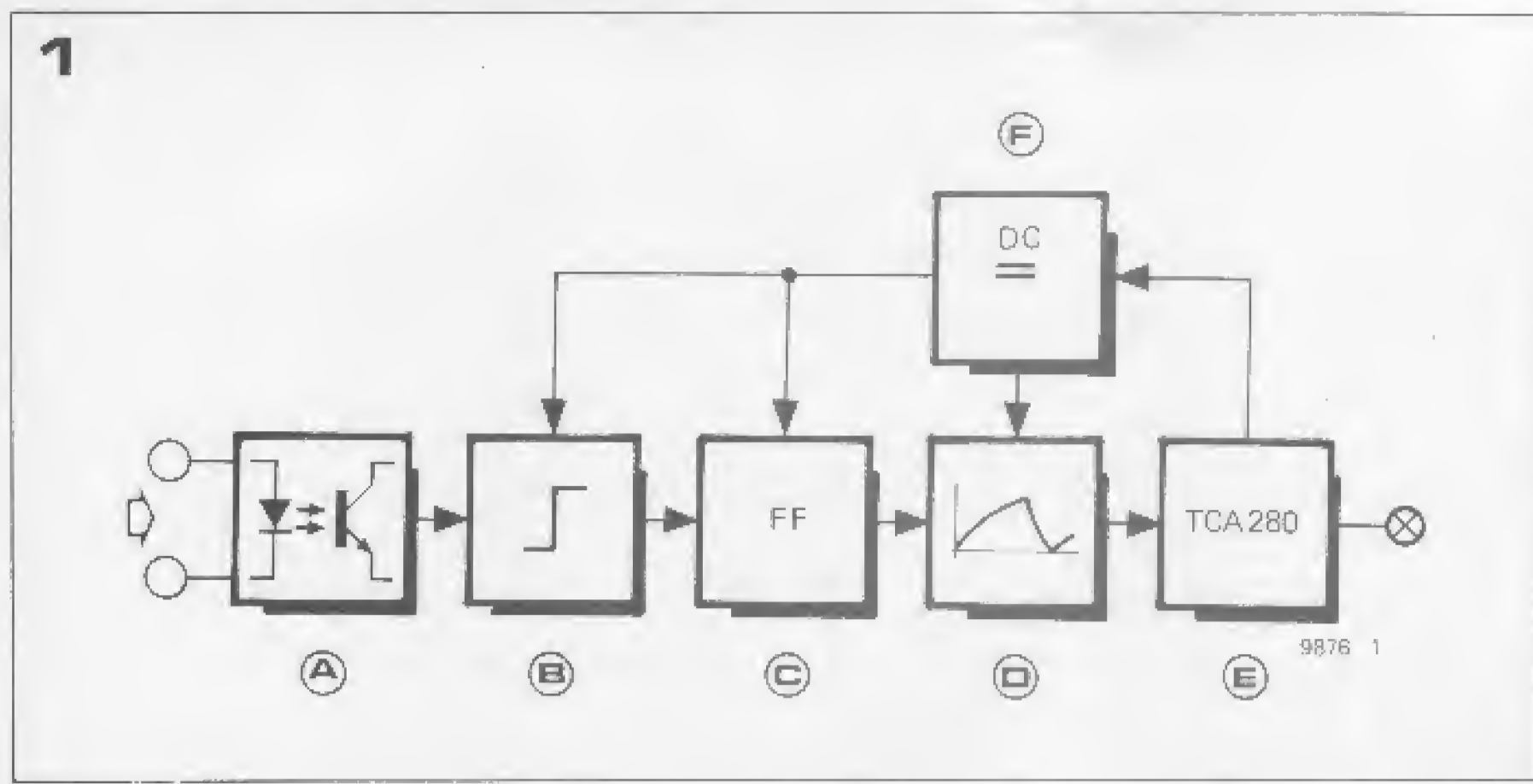

Figure 1. Block diagram of the slow on/off dimmer.

Figure 2a. Control circuit of the slow on/off fader.

Figure 2b. Dimmer and power supply section of the slow on/off fader.

Figure 2c. Operating principle of the TCA 280. The IC generates a sawtooth voltage synchronous with the mains waveform, which is fed to a comparator together with a control voltage that determines at what point on the sawtooth (and hence on the mains waveform) the comparator triggers the triac.

Figure 3. Suggested printed circuit board layout for the slow on/off fader.

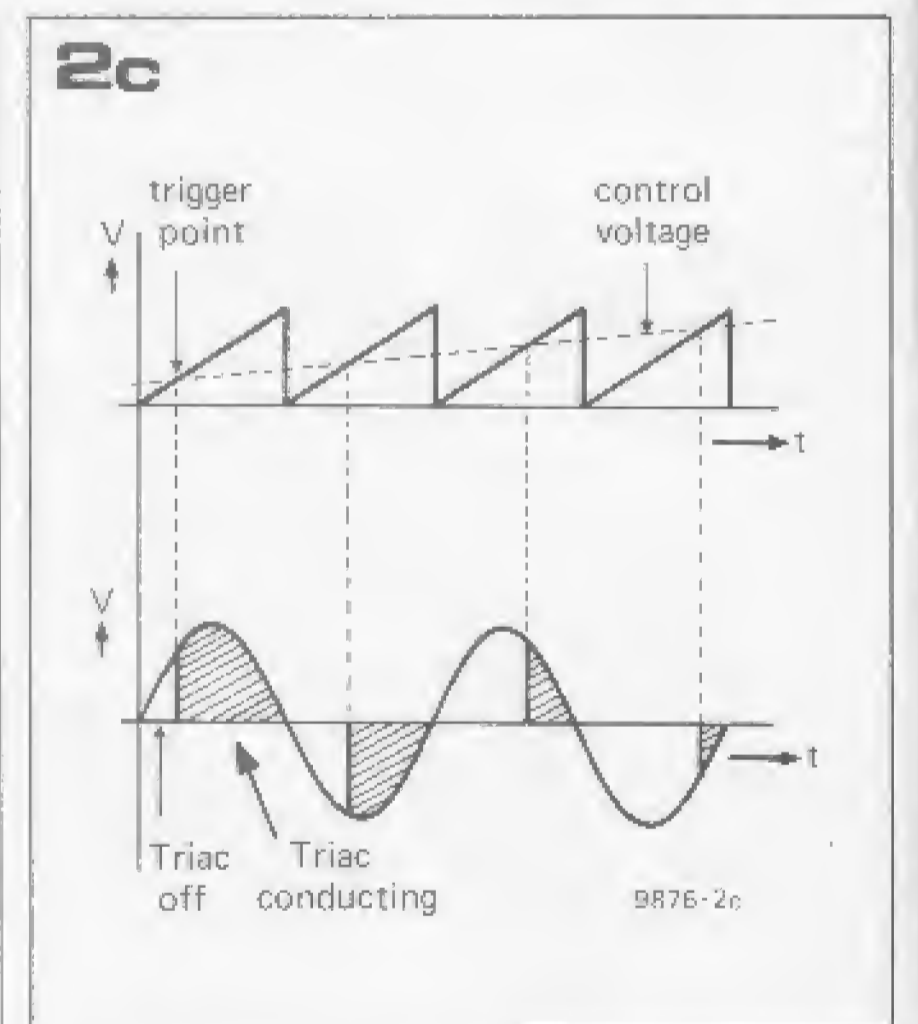
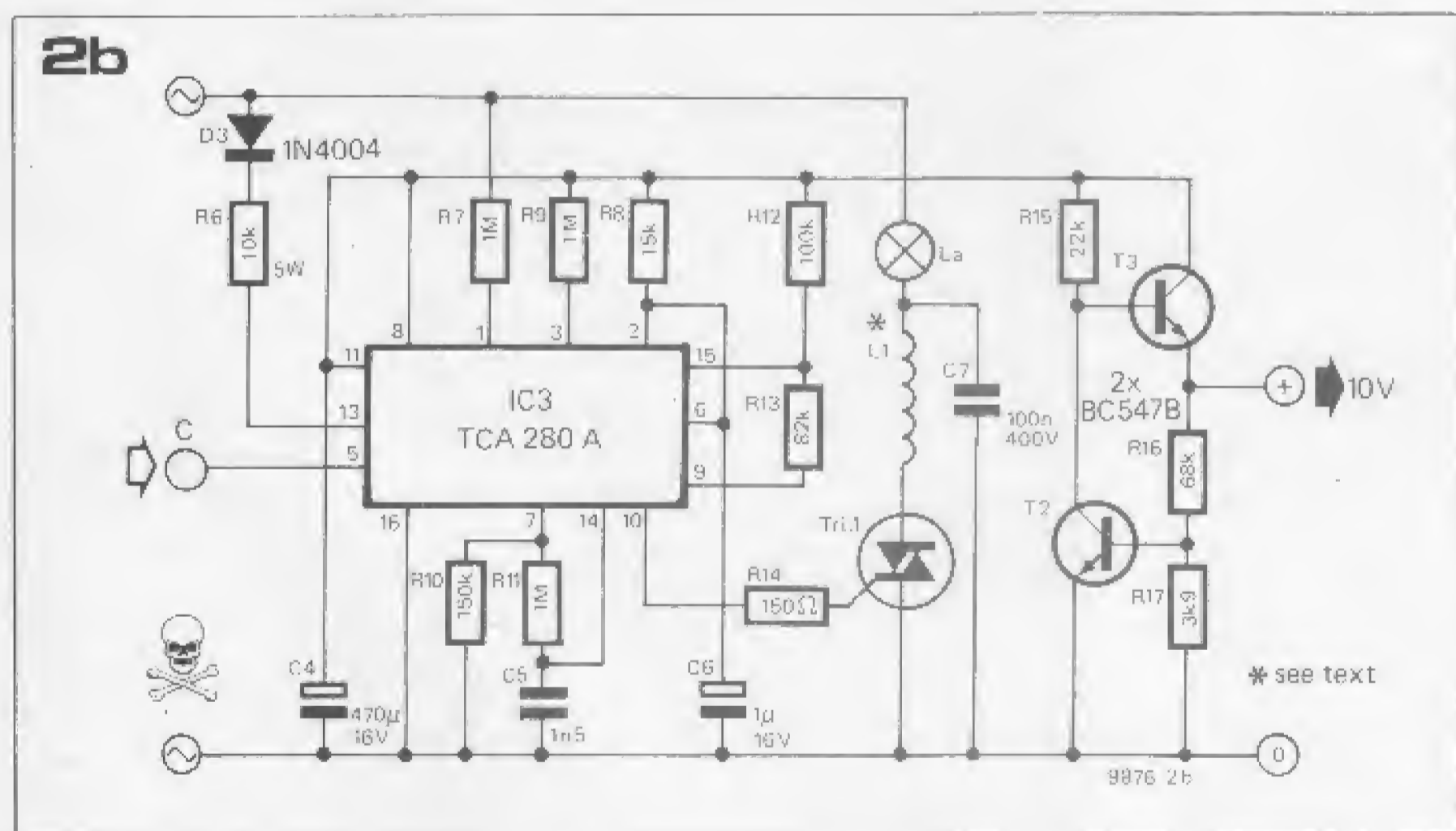
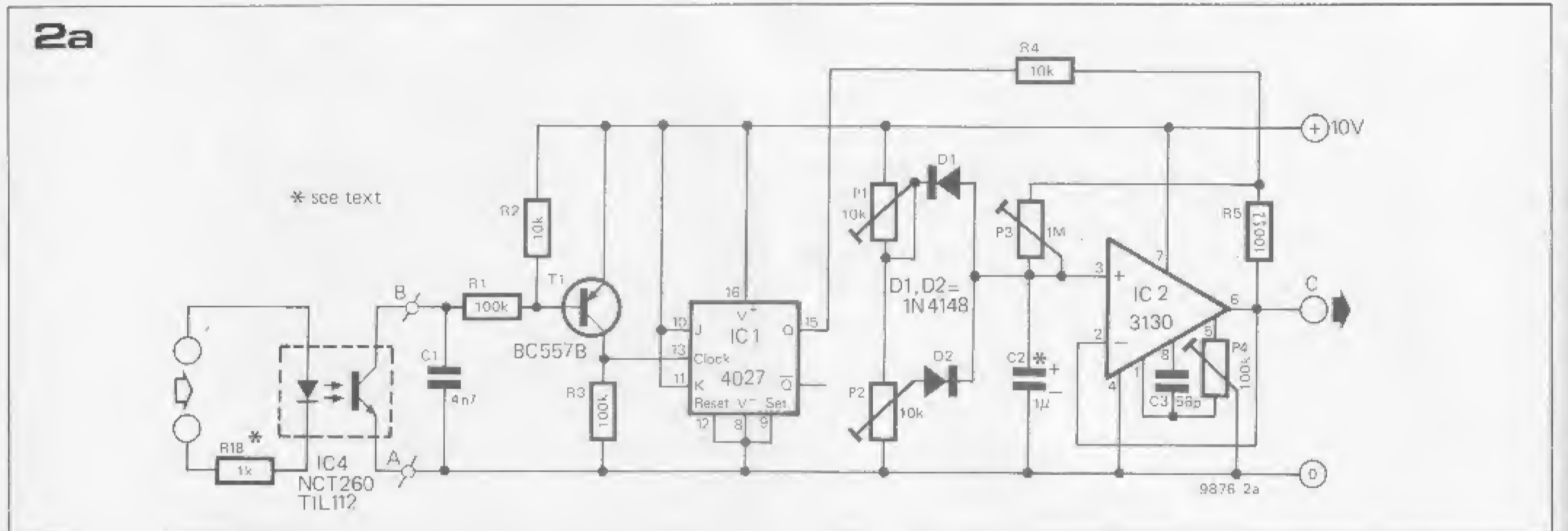

across R6 and a current of several milliamps flows through it, this resistor dissipates an appreciable amount of power and should be rated at 5 watts. Since the supply to the TCA 280 is unstabilised the voltage varies slightly as the trigger point changes, due to the IC drawing varying amounts of current. To avoid lamp flicker the circuit of figure 2a must have a stable supply voltage, and this is derived by a two-transistor regulator T2/T3 in figure 2b. The operation of this circuit is extremely simple. If the output voltage should tend to rise above 10 V the base-emitter voltage of T2 will increase and this transistor will draw more current, pulling down the base voltage of T3, and with it the output voltage. If the output voltage should tend to fall then T2 will

draw less current and the base voltage of T3 will rise.

Construction

The circuit should be housed either in a totally insulating (plastic) box, or in a metal box which is connected to mains earth, the circuit itself being completely insulated from the metal box. In either case, no part of the circuit should be accessible from the outside, with the exception of the two input leads to the opto-isolator. Note that there must be no electrical connection between the input and output of the opto-isolator. If manual control with a pushbutton is required then the pushbutton, which should be rated for mains operation as regards insulation, must be mounted on

the box that houses the circuit, or else connected by double insulated cable (the type with insulation on the conductors plus an outer sheath).

If the circuit is to be controlled by a timer or other electronic circuit then the output switch, relay or transistor of the controlling device must be arranged to switch on the opto-isolator LED. The LED series resistor R18 should be chosen to ensure that the LED current does not exceed 25 mA.

L1 is a normal interference-suppressor coil intended for use with triacs.

Adjustment

To adjust the circuit, the wiper of P1 is first turned fully towards positive supply, the wiper of P2 is turned fully

3

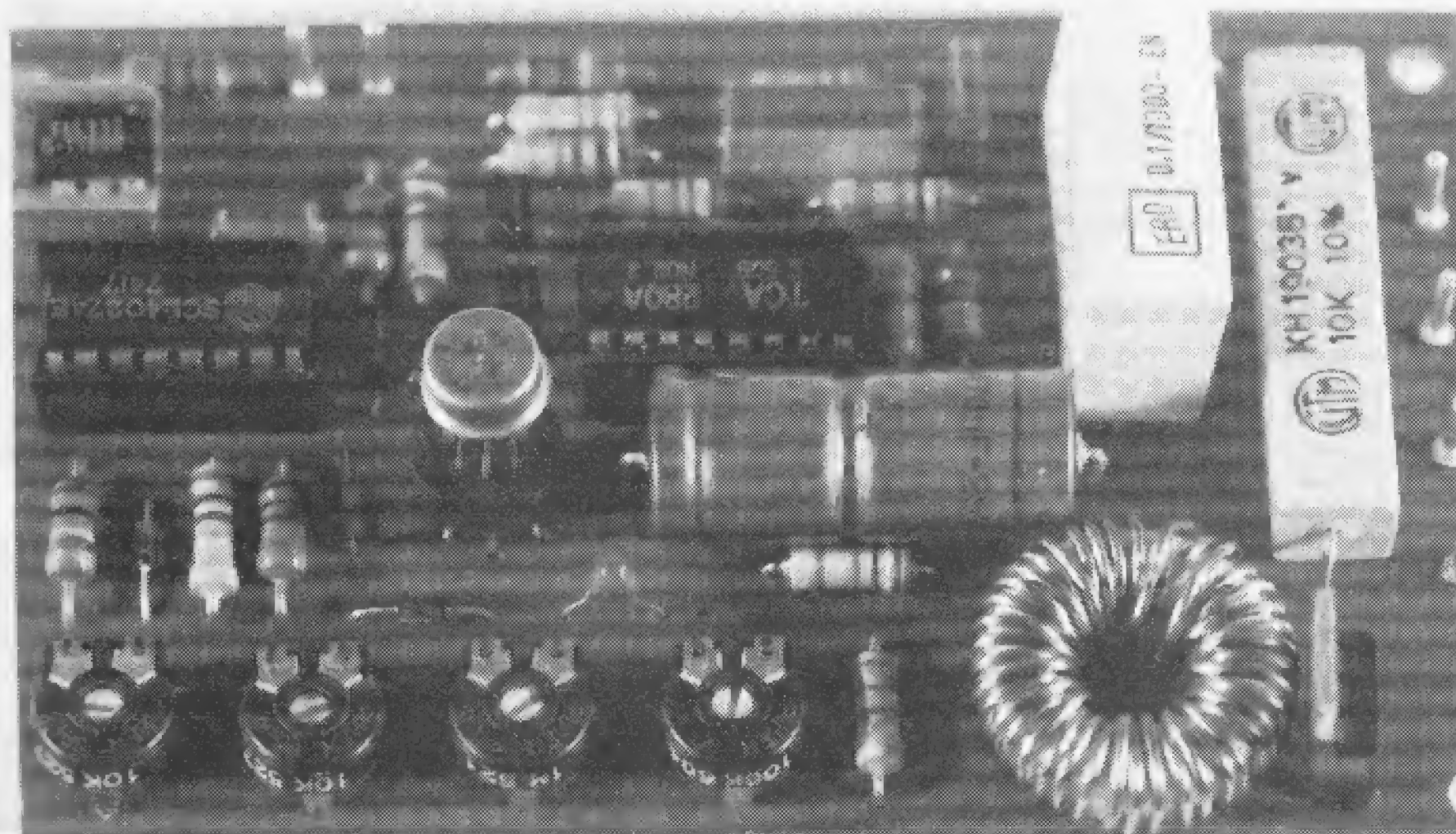
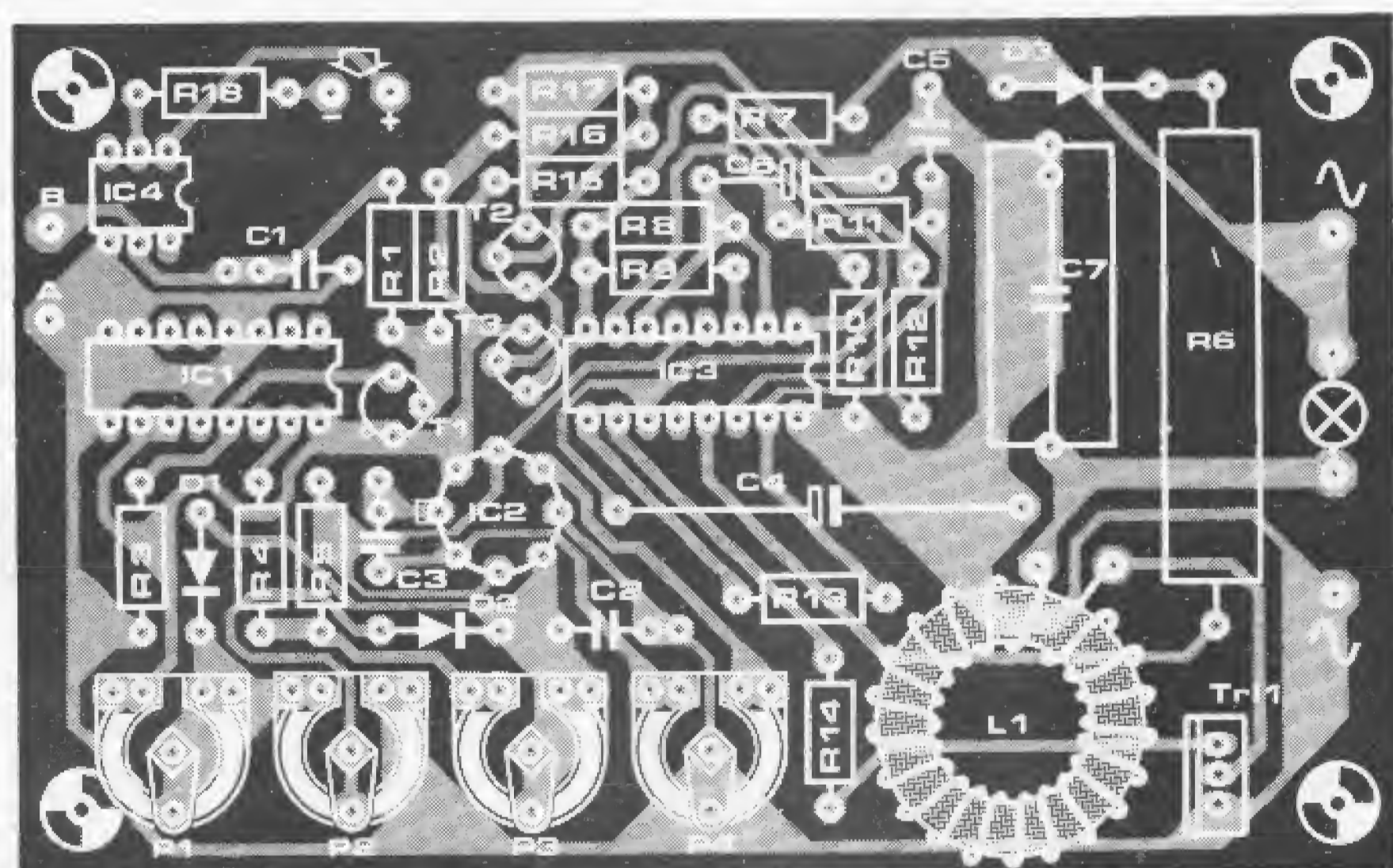
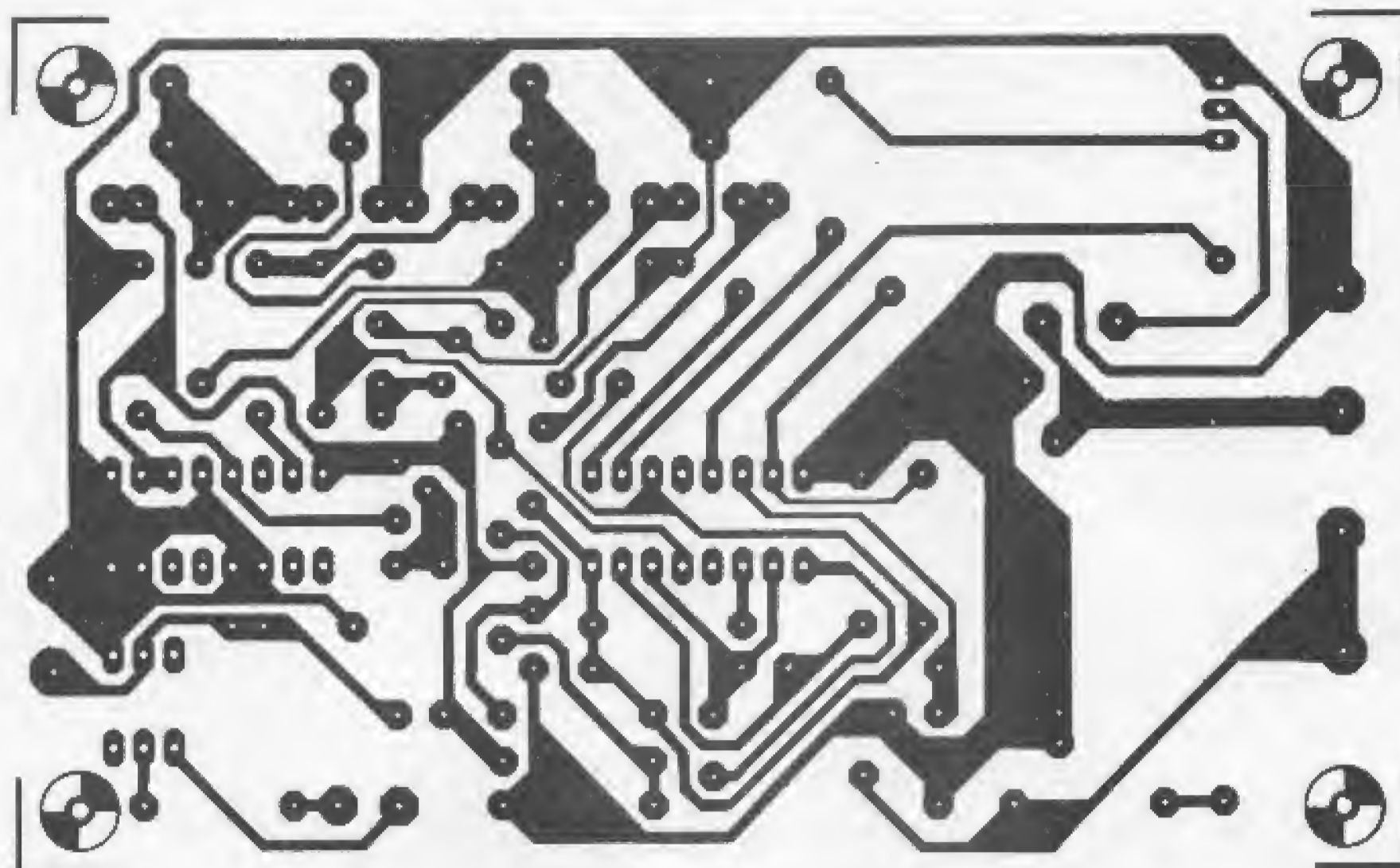

to 0 V, and P3 is set to about its mid-position. The circuit is then set and reset several times, adjusting the offset potentiometer P4 until the time taken to fade up and the time taken to fade down are the same.

The minimum brightness can then be set using P1 and the maximum brightness set using P2 (note that P1 interacts with P2 and so must be adjusted first). Finally, the fade up/down time can be adjusted using P3.

The value of C2 given should be adequate for most purposes, and fade up/down times from less than one second to over a minute can be set by means of P3. However, C2 may be changed to suit individual requirements, but should always be a low leakage type (polyester or polycarbonate).

CMOS function generator

The aim of this project was to produce a simple, cost-effective, general purpose audio generator, which was easy to build and use. This aim has certainly been achieved, since the circuit offers a choice of sine, square and triangle waveforms and a frequency range from about 12 Hz to 70 kHz, yet uses only one CMOS hex inverter IC and a few discrete components. Of course, the design does not offer the performance of more sophisticated circuits, particularly as regards waveform quality at higher frequencies, but it is nonetheless an extremely useful instrument for audio work.

Block diagram

Figure 1 illustrates the operating principles of the circuit. The heart of the generator is a triangle/squarewave generator consisting of an integrator and a Schmitt trigger. When the output of the Schmitt trigger is high, the voltage fed back from the Schmitt output to the input of the integrator causes the integrator output to ramp negative until it reaches the lower trigger threshold of the Schmitt trigger. At this point the output of the Schmitt trigger goes low, and the low voltage fed back to the integrator input causes it to ramp positive until the upper trigger threshold of the Schmitt trigger is reached. The output of the Schmitt trigger again goes high, and the integrator output ramps negative again, and so on. The positive- and negative-going sweeps of the integrator output make up a triangular waveform, whose amplitude is determined by the hysteresis of the Schmitt trigger (i.e. the difference between the upper and lower trigger thresholds). The output of the Schmitt trigger is, of course a square wave consisting of alternate high and low output states.

The triangle output is fed through a buffer amplifier to a diode shaper, which 'rounds off' the peaks and troughs of the triangle to produce an approximation to a sinewave signal.

Any one of the three waveforms may then be selected by a three-position switch and fed to an output buffer amplifier. The frequency of all three

Using only one inexpensive CMOS IC and a handful of discrete components, it is possible to build a versatile function generator that will provide a choice of three waveforms over the entire audio spectrum and beyond.

signals is varied by altering the integrator time constant, which changes the rate at which the integrator ramps, and hence the signal frequency.

Complete circuit

The practical circuit of the CMOS function generator is given in figure 2. The integrator is based on a CMOS inverter, N1, whilst the Schmitt trigger uses two inverters with positive feedback, N2 and N3.

The circuit functions as follows; assuming, for the moment, that the wiper of P2 is at its lowest position, when the output of N3 is high a current

$$\frac{U_b - U_t}{P_1 + R_1}$$

flows through R1 and P1, where U_b is the supply voltage and U_t is the threshold voltage of N1. Since this current cannot flow into the high impedance input of the inverter, it all flows into C1 or C2 (depending on which is selected by S1).

The voltage drop across C1 thus increases linearly, so the output voltage of N1 falls linearly until the lower threshold voltage of the Schmitt trigger is reached, when the output of the Schmitt trigger goes low. A current

$$\frac{-U_t}{P_1 + R_1}$$

now flows through R1 and P1. This current also flows into C1, so the output voltage of N1 rises linearly until the upper threshold voltage of the Schmitt trigger is reached, when the output of the Schmitt trigger goes high and the whole cycle repeats.

To ensure symmetry of the triangle waveform (i.e. the same slope on both positive-going and negative-going portions of the waveform) the charge and discharge currents of the capacitor must be equal, which means that $U_b - U_t$ must equal U_t . Unfortunately U_t is determined by the characteristics of the CMOS inverter and is typically 55% of supply voltage, so $U_b - U_t$ is about 2.7 V with a 6 V supply and U_t is about 3.3 V.

This difficulty is overcome by means of P2, which allows symmetry adjustment. Assume for the moment that R4 is con-

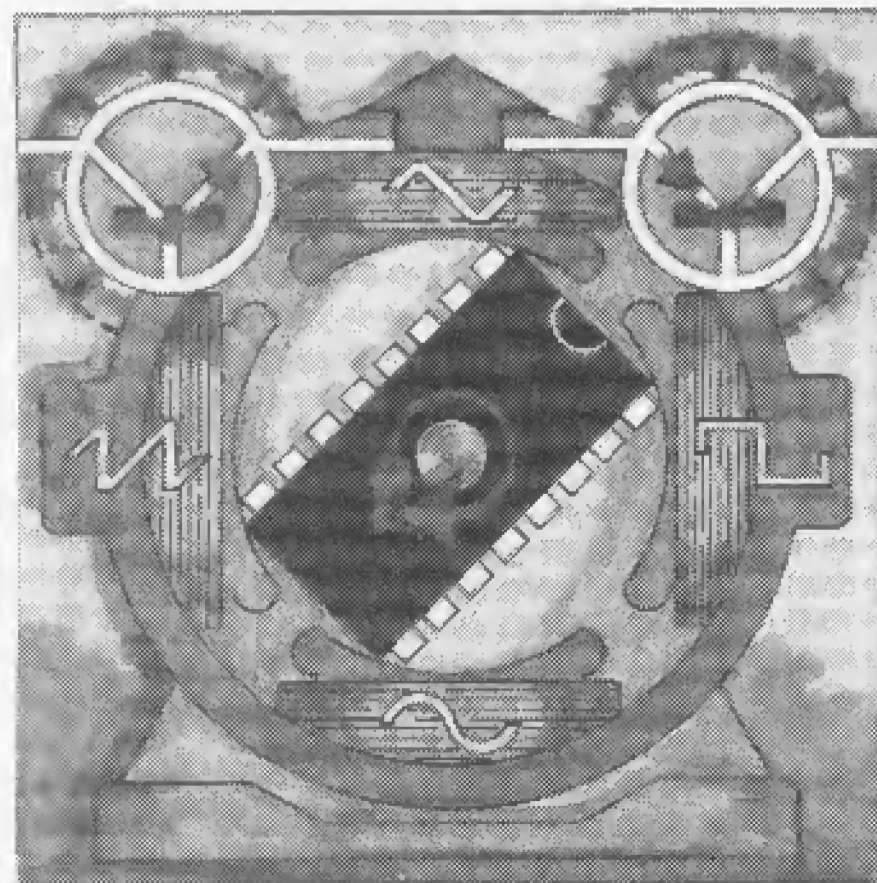

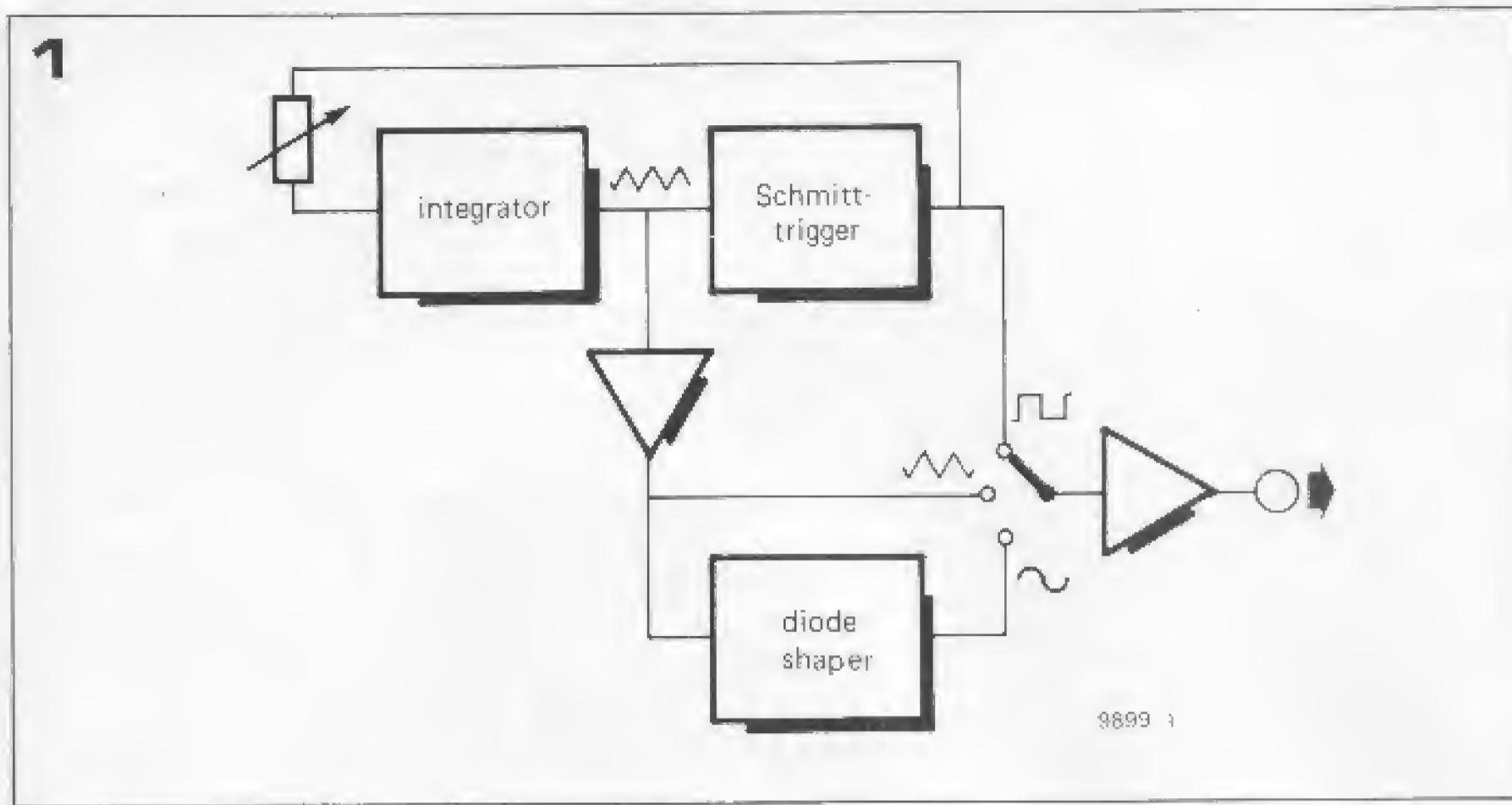
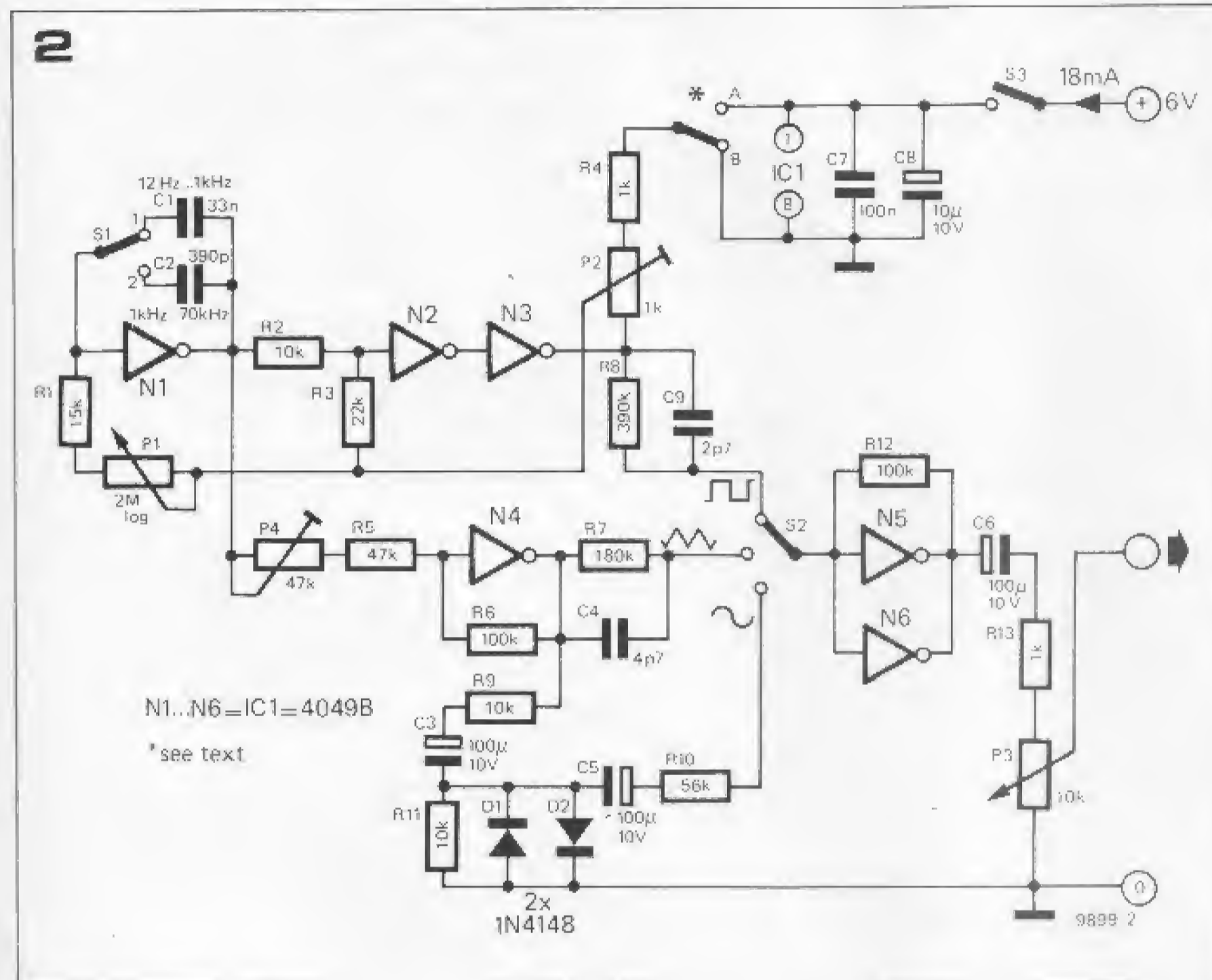

Figure 1. Block diagram of the CMOS function generator.

Figure 2. Complete circuit of the function generator.

Photos. The three output waveforms produced by the function generator.



connected to the positive supply rail (position A). Whatever the setting of P2, the high output voltage of the Schmitt trigger is always U_b . However, when the output of N3 is low, R4 and P2 form a potential divider so that a voltage from 0 V to 3 V can be fed back to P1, depending on the wiper setting of P2. This means that the voltage across R1 and P1 is no longer $-U_t$ but

$U_{p2} - U_t$. If the slider voltage of P2 is about 0.6 V then $U_{p2} - U_t$ will be around -2.7 V, so the charge and discharge currents will be the same. Of course, the adjustment of P2 must be carried out to suit each individual function generator, owing to the tolerance in the value of U_t . In cases where U_t is less than 50% of the supply voltage, it will be necessary to connect

the top of R4 to ground (position B). Two frequency ranges are provided, which are selected by means of S1; 12 Hz-1 kHz and 1 kHz to about 70 kHz. Fine frequency control is provided by P1 which varies the charge and discharge current of C1 or C2 and hence the rate at which the integrator ramps up and down. The squarewave output from N3 is

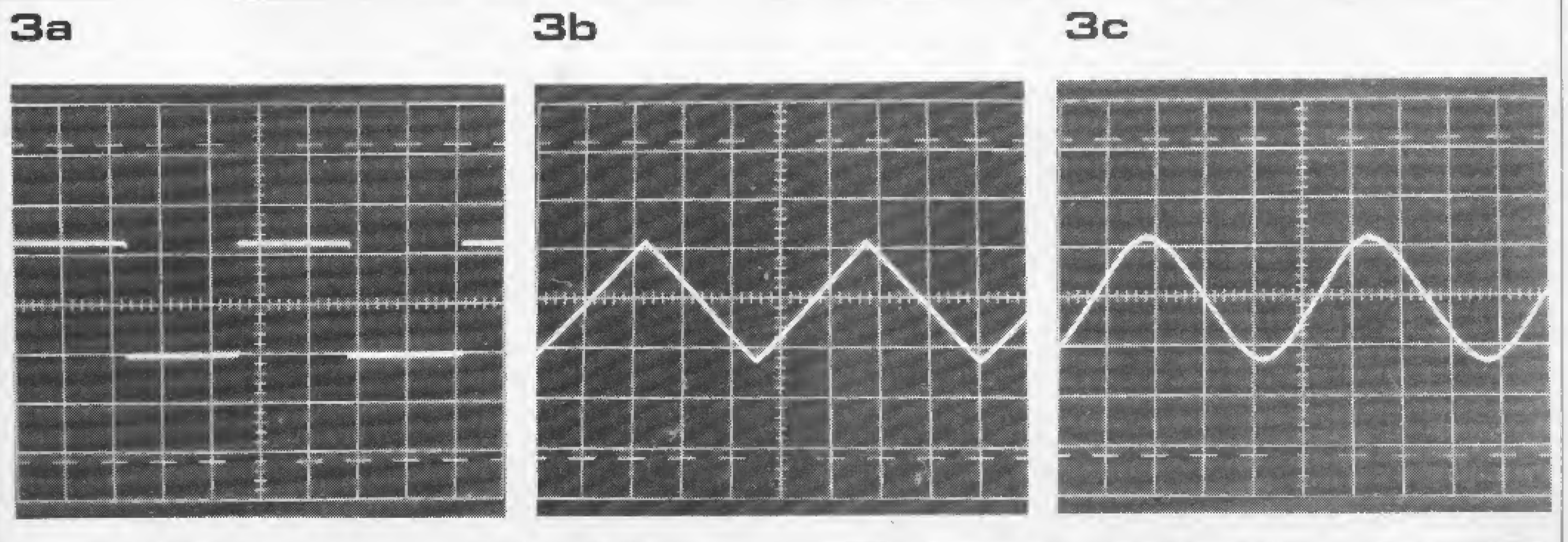

taken via a waveform selector switch, S2, to a buffer amplifier, which consists of two inverters (connected in parallel to boost their output current capability) biased as a linear amplifier. The triangle output is taken through a buffer amplifier N4, and thence through the selector switch to the output buffer amplifier.

The triangle output from N4 is also taken to the sine shaper, which consists of R9, R11, C3, D1 and D2. Up to about plus or minus 0.5 volts D1 and D2 draw little current, but above this voltage their dynamic resistance falls and they limit the peaks and troughs of the triangle signal logarithmically to produce an approximation to a sine wave. The sine output is fed via C5 and R10 to the output amplifier.

Sine purity is adjusted by P4, which varies the gain of N4 and thus the amplitude of the triangle signal fed to the sine shaper. Too low a signal level, and the triangle amplitude will be below the diode threshold voltage, so that it will pass without alteration; too high a signal level, and the peaks and troughs will be clipped severely, thus not giving a good sine wave.

The input resistors to the output buffer amplifier are chosen so that all three waveforms have a peak to peak output voltage of about 1.2 V maximum. The output level can be adjusted by P3.

Adjustment procedure

The adjustment procedure consists simply of adjusting the triangle symmetry and sine purity. Triangle symmetry is actually best adjusted by observing the squarewave signal, since a symmetrical triangle is obtained when the squarewave duty-cycle is 50% (1-1 mark-space ratio). P2 is adjusted to achieve this. In cases where the symmetry improves as the wiper of P2 is turned down towards the output of N3 but exact symmetry cannot be obtained, the top of R4 should be connected in the alternative position.

Sine purity is adjusted by varying P4 until the waveform 'looks right' or by adjusting for minimum distortion if a distortion meter is available. Since the supply voltage alters the output voltage of the various waveforms, and hence the sine purity, the circuit should be operated from a stable 6 V supply. If batteries are used they should never be allowed to run down too far.

CMOS ICs used as linear circuits draw more current than when used in the normal switching mode, and the supply voltage should not be greater than 6 V, otherwise the IC may overheat due to excessive power dissipation.

Performance

The quality of the waveforms can be judged from the oscilloscope photographs. In all three cases the vertical sensitivity is 500 mV/div and the timebase speed 200 μ s/div. ■



In many cases the breakdown voltage of a zener diode is printed, fairly clearly, on the case. For example, the type number of the zener family is often printed, together with the zener voltage, so a BZY88 6V8 would be a 6.8 V zener from the BZY88 family. Unfortunately, some manufacturers merely print an indecipherable code, which has to be looked up in the relevant data book in order to find the zener parameters. Furthermore, there is sometimes a requirement for testing 'job lots' of unmarked devices, or components that have been lying in the junkbox and have had their markings rubbed off. In all these cases a zener tester can prove a useful addition to the 'lab' test equipment.

The reverse characteristic of a zener diode is illustrated in figure 1. At voltages below the zener voltage the device draws very little current. Once the breakdown voltage is reached any further increase in voltage will produce a large increase in current, i.e. above its breakdown voltage the zener diode behaves as a more or less constant voltage device. However, since the zener diode possesses a finite internal resistance (known as the dynamic resistance), the zener voltage will vary slightly with current, due to the voltage dropped across this internal resistance. Because of this, manufacturers always quote zener voltage at a certain current (usually between 5 and 10 mA).

It is, of course, possible to test a zener diode using a battery, series resistor and a multimeter to measure the zener voltage. However, the current flowing through the zener will be determined by the value of the resistor and the difference between the battery voltage and the zener voltage, and will obviously be less for high-voltage zeners than for low-voltage zeners. This can lead to errors in the measurement.

The zener tester described in this article feeds a known, constant current through the zener. Furthermore, a choice of seven different zener currents is provided, which allows the zener voltage to be plotted against current.

The circuit of the zener tester, which contains only nine components, is given in figure 2. T1 and T2 function

This simple tester provides a reliable means of measuring zener voltages and of plotting the variation of zener voltage with zener current.

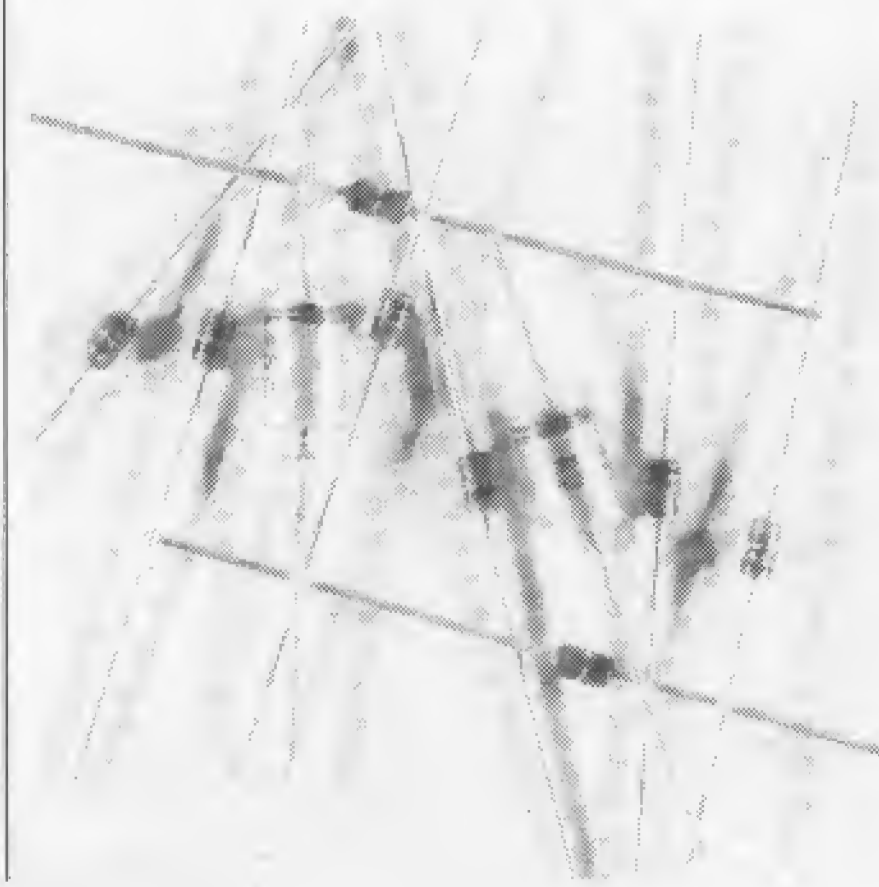

1

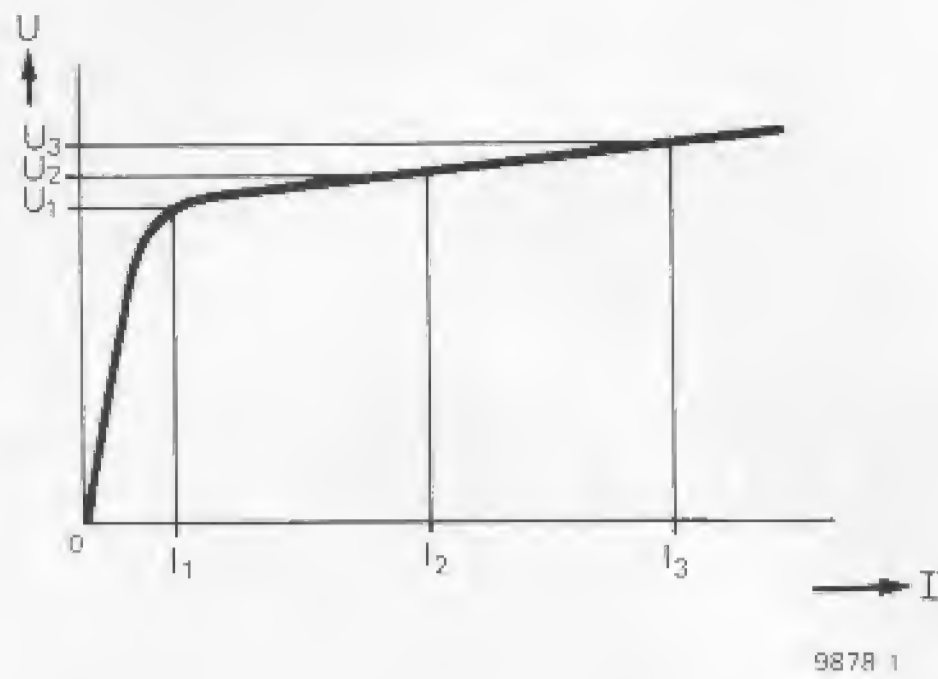

Figure 1. Voltage versus current characteristic of a zener diode. Even when the breakdown voltage has been reached, the zener voltage varies slightly with current.

Figure 2. Circuit of the zener tester. Pressing S1, S2 or S3 in various combinations feeds a choice of seven different constant currents through the zener and the zener voltage is measured with a multimeter.

Figure 3. A voltage versus current curve for the zener may be plotted, from which the dynamic resistance may be found.

Table 1. The theoretical currents for the various combinations of S1, S2 and S3. These may vary in practice by 10%, due to component tolerances.

as a voltage regulator. T1 receives a bias voltage from the supply via R4 and draws current from the supply through the zener under test. However, if the emitter voltage should try to rise above the 0.6 V base emitter knee voltage of T2, then T2 will draw more current, pulling down the base voltage of T1 and thus reducing the emitter voltage. Should the emitter voltage of T1 tend to fall below the base-emitter voltage of T2, then T2 will draw less current, the collector voltage will rise, and with it the emitter voltage of T1. This negative feedback system means that a constant voltage of approximately 0.6 V appears at the emitter of T1.

If one or more of the switches S1 to S3 is closed, then a current $I = \frac{0.6}{R}$ (A, V, Ω)

will flow through one or more of the resistors R1-R3. ('R' is R1, R2, R3 or the parallel connection of two or more of these). This current will also flow through T1 and the zener. The zener voltage can then be measured by connecting a multimeter across it as shown. This should have a fairly high resistance (20,000 Ω /V or higher), so that it does not 'rob' too much current from the zener. By pressing one or more switches in different combinations a total of seven different zener currents can be obtained.

The zener currents for different combinations of the switches are shown in table 1. However, it should be noted that the actual currents obtained may vary by 10% from these figures, due to resistor tolerances and the temperature coefficient of T2.

The values of zener voltage obtained for different zener currents may be plotted on a graph of zener voltage versus zener current, as shown in figure 3. The dynamic resistance of the zener can then be calculated by dividing an increment in voltage, ΔU , by the corresponding increment in current, ΔI , i.e.

$$R_{dynamic} = \frac{\Delta U}{\Delta I}$$

With the supply voltage shown, the maximum voltage that can appear between positive supply and the

2

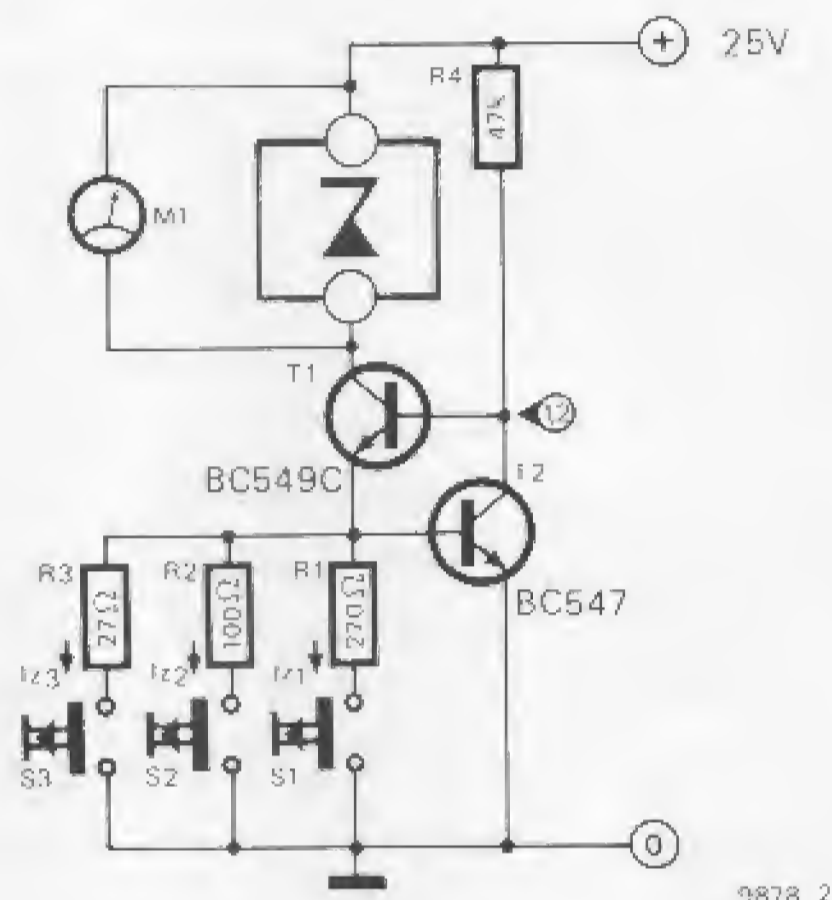

9878 2

3

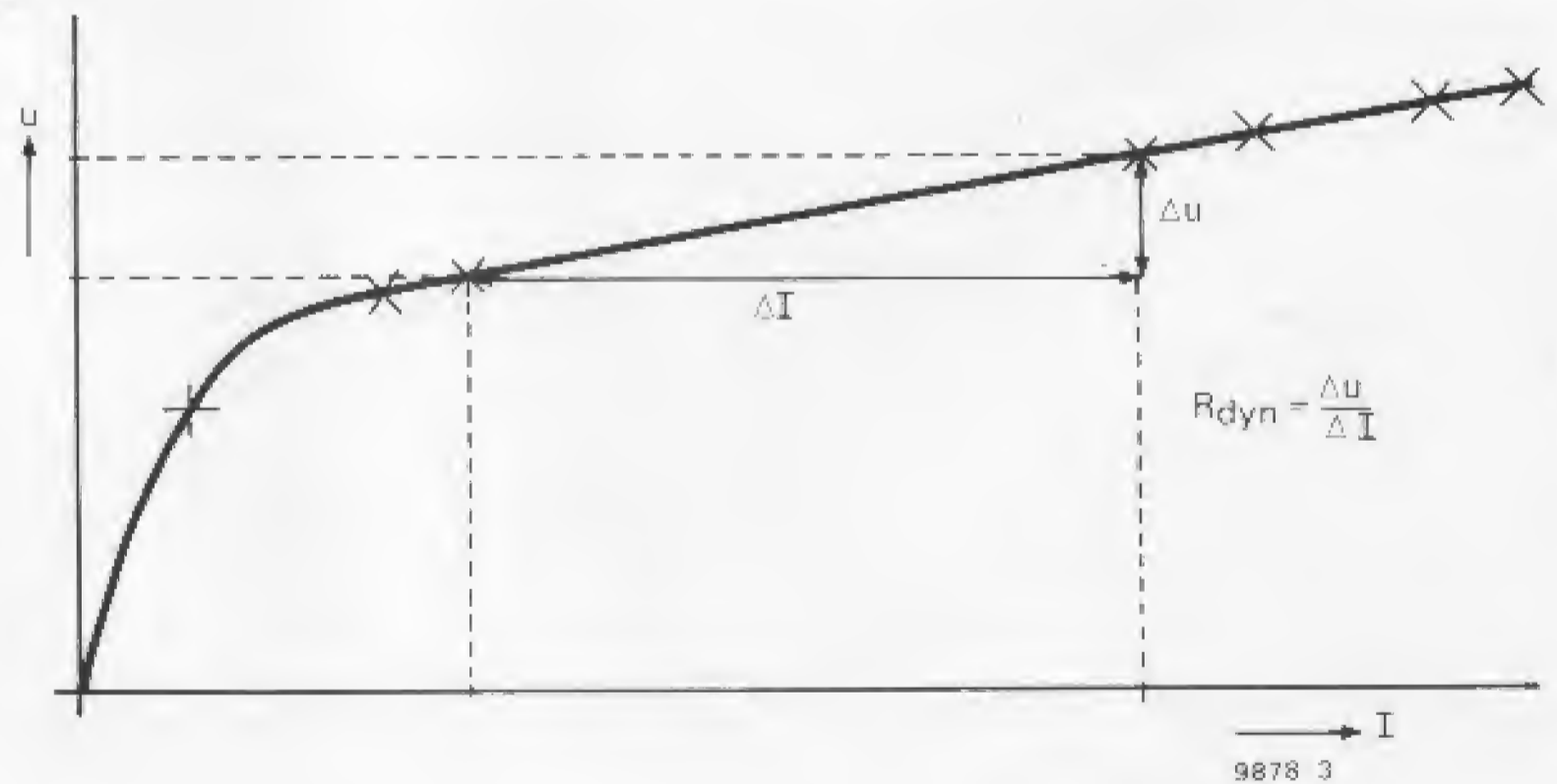

9878 3

Switch	U _b	I _z
S1	25 V	2.22 mA
S2	25 V	6 mA
S3	25 V	22.2 mA
S1 + S2	25 V	8.2 mA
S1 + S3	25 V	24.4 mA
S2 + S3	25 V	28.2 mA
S1 + S2 + S3	25 V	30 mA

collector of T1 without T1 saturating is about 23 V. The maximum zener voltage that can be measured is thus about 22 V. The circuit may be modified to test higher voltage zeners by using a higher voltage transistor for T1, but care will have to be taken not to exceed the dissipation of T1 or the zener on the higher current ranges.

As the zener current is determined exclusively by the base-emitter voltage of T2 and R1 to R3, a stabilised supply voltage is not necessary, and an 18 V/50 mA transformer, 30 V/50 mA bridge rectifier and 470 μ /35 V capacitor will make a perfectly adequate unregulated supply. ◀

development timer

The question which will no doubt arise in many readers' minds will be — 'is such a complicated timer system really useful, particularly in view of the fact that no commercial manufacturer has produced a timer with these facilities?' The answer to this must certainly be yes. Ordinary timers, which merely sound a buzzer at the end of a preset interval, are fine for exposure purposes, but useless for development, since they can give no indication of the intervals at which tank agitation must be carried out. An ordinary clock can be used, but since it gives no audible warning it must be watched all the time, which does not allow the user to carry out any other tasks during the development period.

Block diagram

A block diagram of the development timer is given in figure 1. Block A is a clock pulse generator, the high- and low-phases of which can be independently adjusted by P1 and P2. The time for which the clock pulse is high is the interval between tank agitations. When the clock pulse is low a low-frequency audio tone sounds to indicate the time for which the tank must be agitated. Block B is a counter, presettable from one to 17, which counts clock pulses to give the total development time. When the required count is reached a high-frequency audio tone sounds to indicate that development is complete and the clock generator is inhibited via the 'stop' line. Two pushbuttons are provided, a 'reset' button, which switches off the high audio signal and resets the timer ready for the next operation, and a 'start' button, which not only resets the timer, but also starts the next timing sequence.

Complete circuit

Figure 2 is the complete circuit of the development timer. Since the stability of the timer must be no worse than a few percent to achieve repeatable development, a temperature-compensated clock generator is used, based on a 3130 FET op-amp IC1.

When the output of IC1 is high, the voltage on the non-inverting input is held at approximately two-thirds of

Developing photographic films can be something of a chore. Not only is it necessary to measure the total development time, but it is also necessary to agitate the development tank at frequent intervals to ensure even development of the film. This means that the clock must be watched continuously. The development timer described in this article overcomes these problems by measuring the intervals at which and the length of time for which the tank must be agitated, as well as the total development time.

supply voltage via R1, R3 and R2. C1 and C2 charge via P1, R4 and D4 until the voltage at the inverting input of IC1 exceeds that at the non-inverting input, when the output of the IC will go low. C1 and C2 will now discharge via D5, R5 and P2 (and incidentally via D1, R2, R3 and D2) until the voltage at the inverting input falls below that at the non-inverting input, when the output will go high and the cycle will repeat. C1 and C2 thus charge and discharge between about one-third and two-thirds supply voltage.

The charge (high output) phase of the clock is, of course, controlled by the setting of P1, whilst the discharge (low output) phase is controlled by P2. The total time for both phases can be varied from about 30 seconds to over 2 minutes.

To stop the clock generator during the reset period, the inhibit input of IC1, pin 8, is taken low via D6, which holds the output of IC1 high.

The clock generator is started by setting the RS flip-flop N2/N3 with the start button, which takes the output of N3 high and removes the inhibition on IC1. It is important that the clock generator should always start in the same phase, i.e. the discharge phase when the output is low. To achieve this several refinements have been incorporated in the circuit. To begin with, while IC1 is inhibited, C1 and C2 must be prevented from charging up to full supply voltage, as this would mean that the first discharge cycle would begin from full supply voltage instead of two-thirds supply voltage. This would make the first low output phase of the clock longer than all the rest.

On the other hand, if the clock was started immediately after applying power to the circuit, C1 and C2 would be uncharged, and the clock would immediately go into the high output phase.

Two measures are taken to prevent these occurrences. C1 and C2 cannot charge to much above two-thirds supply voltage when the output of IC1 is high, as D1 will become forward biased and will clamp the voltage on C1 and C2. To prevent the clock starting in the high

Specification

- a. Tank agitation time: variable between 5 and 25 seconds.
- b. Interval between agitations: variable between 25 and 120 seconds.
- c. Total development time: variable from one to seventeen times (a + b)
- d. 'agitate' signal frequency: 1.4 kHz
- e. 'development complete' signal frequency: 4 kHz
- f. current consumption: quiescent, 1 mA
during audio tone, 3 to 50 mA.

1

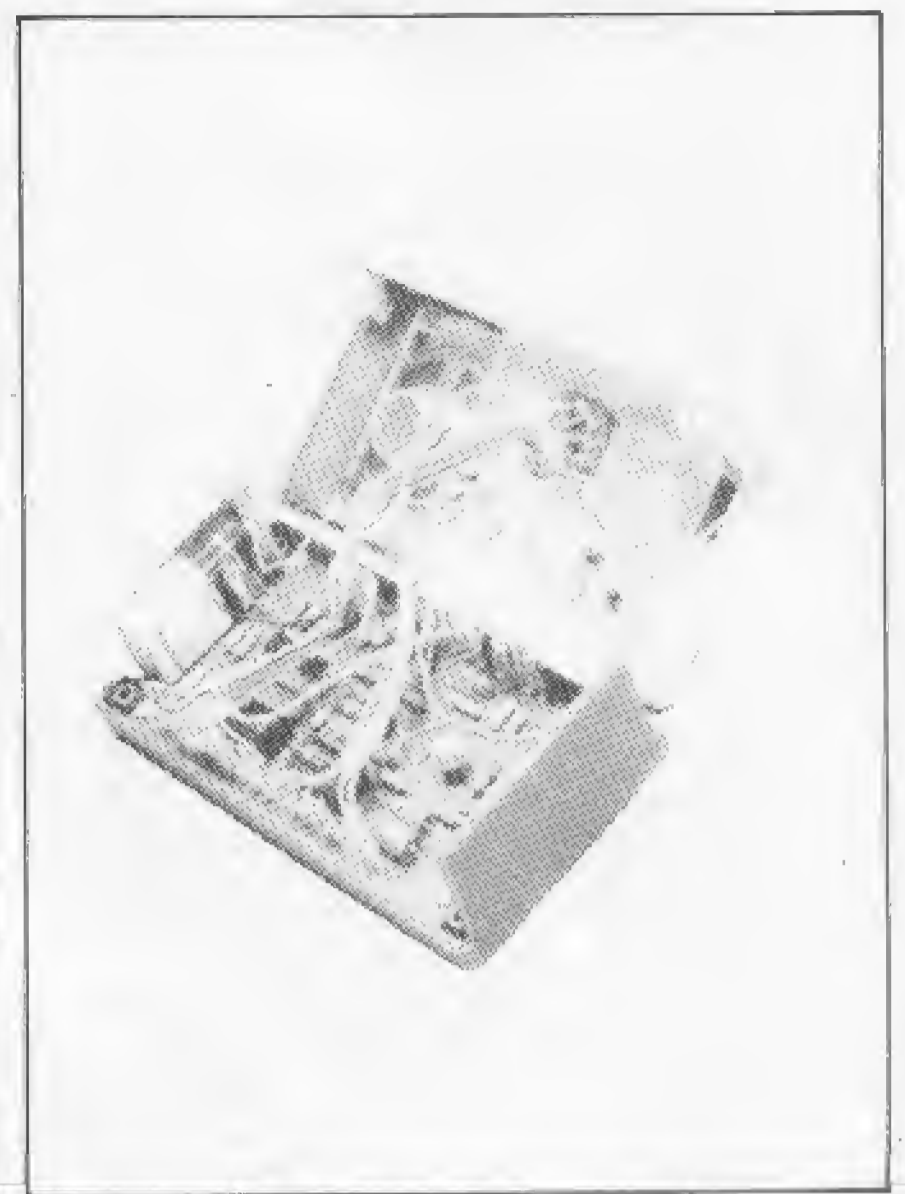
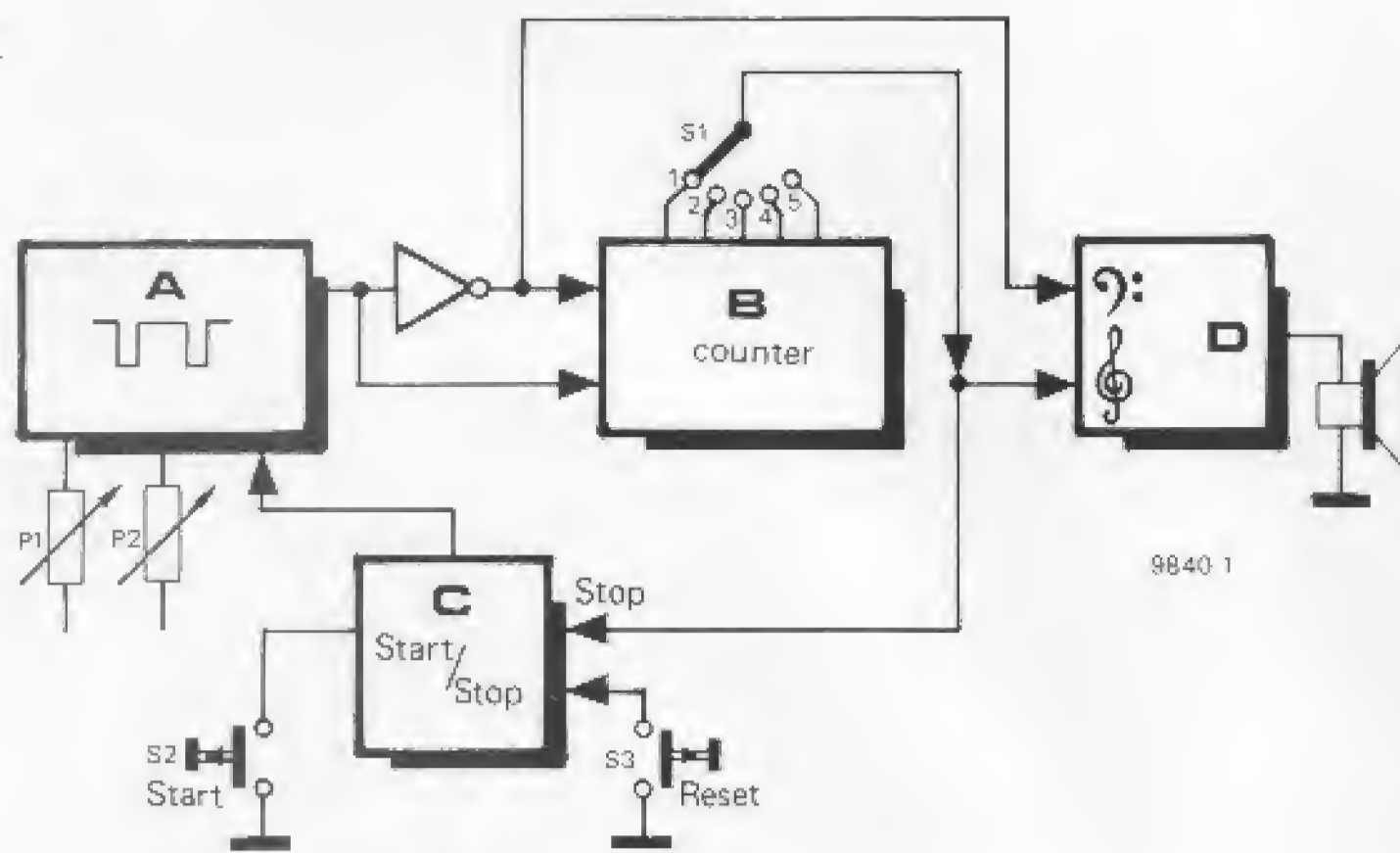

Figure 1. Block diagram of the development timer, which illustrates all the principal features.

Figure 2. Complete circuit of the development timer.

output phase, whenever the circuit is in the reset condition (which condition it must be put in after switching on the power) C1 and C2 are charged rapidly from the high output of N2 via R17 and D15.

Having described the clock circuit in detail, the operation of the rest of the circuit is as follows: pressing the start button takes the input of N3 low, setting flip-flop N2/N3. The high-going output of N3 is differentiated by C3 and R7 to provide a short positive spike that resets counters IC3 and IC4 (if not already reset). This is shown in the timing diagram of figure 3. The inhibition is removed from IC1, so the clock output goes low while C1 and C2 discharge from two-thirds supply

voltage. The output of N1 is thus high and applies a control voltage via R12 and D12 to a current-controlled oscillator N5/N6, causing it to produce a low-frequency audio tone.

The signal from the output of N6 is used to trigger a monostable multivibrator N7/N8. This produces a train of pulses with the same frequency as the output of N6, but with a much smaller duty-cycle, which are then fed to a buffer T1/T2 and loudspeaker to produce an audible signal. The use of short-duty-cycle pulses produces a signal with quite a high peak loudness, but the average current consumption from the supply is kept low. The low frequency audio tone indicates that the tank should be agitated.

2

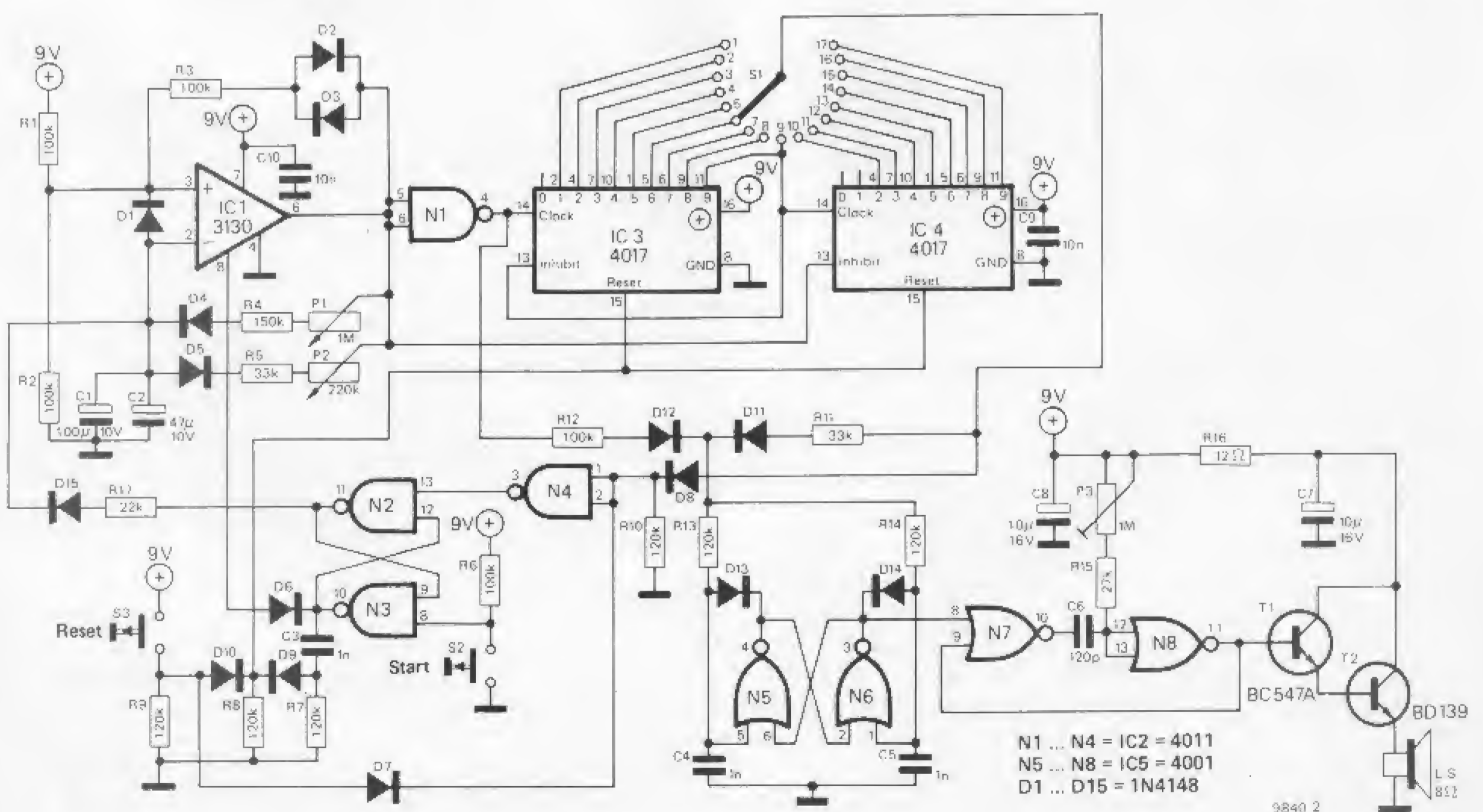

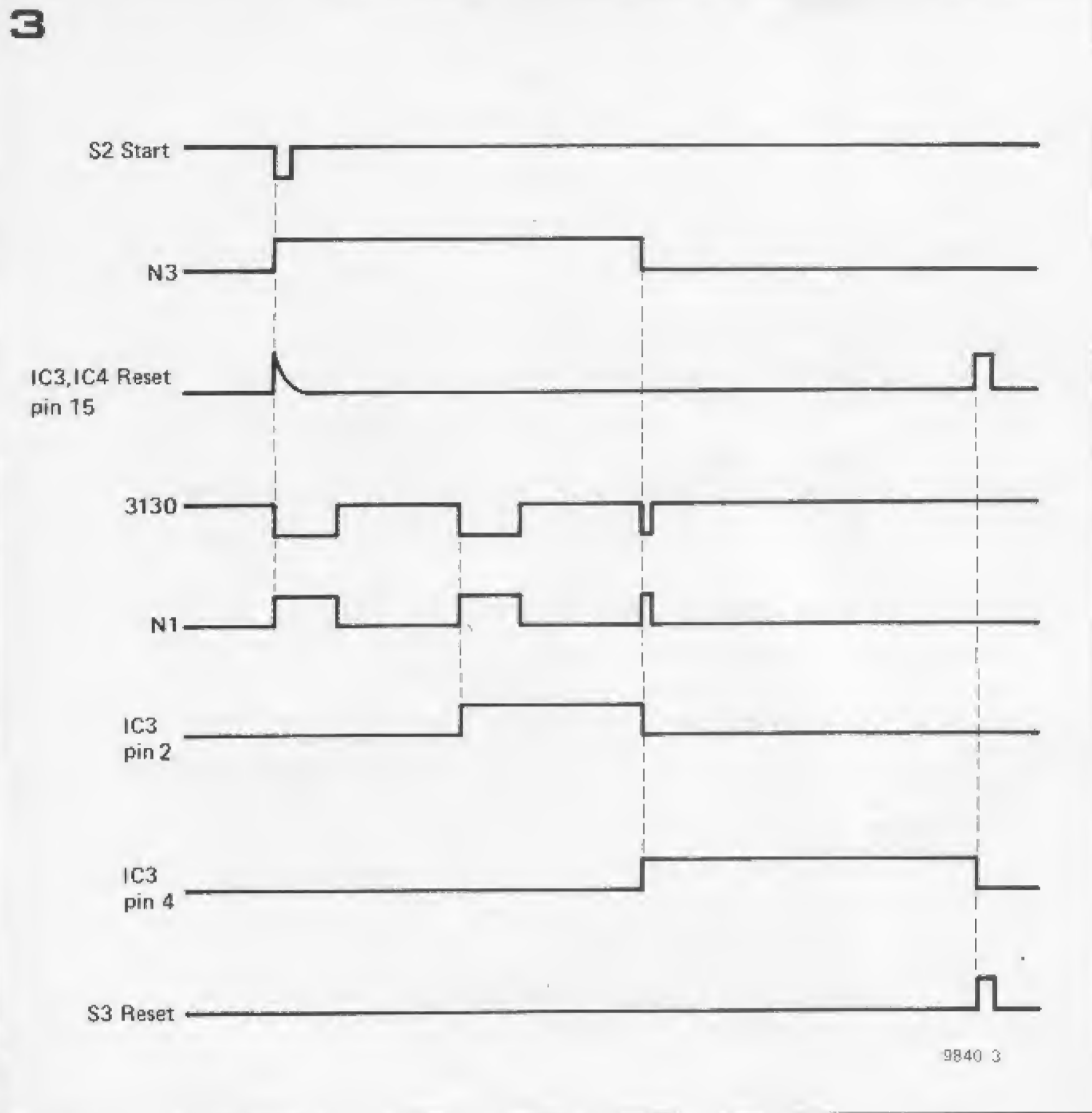
**Parts list to figure 4.****Resistors:**

R1,R2,R3,R6,R12 = 100 k
 R4 = 150 k
 R5,R11 = 33 k
 R7,R8,R9,R10,R13,R14 = 120 k
 R15 = 27 k
 R16 = 12 Ω
 R17 = 22 k

Capacitors:

C1 = 100 μ /10 V tantalum
 C2 = 47 μ /10 V tantalum
 C3,C4,C5 = 1 n
 C6 = 120 p
 C7,C8 = 10 μ /16 V
 C9,C10 = 10 n

Semiconductors:

T1 = BC 547A
 T2 = BD 139
 D1 . . . D15 = DUS (1N4148)
 IC1 = CA 3130
 IC2 = CD 4011
 IC3,IC4 = CD 4017
 IC5 = CD 4001

Miscellaneous:

P1 = 1 M lin potentiometer
 P2 = 220 k lin potentiometer
 P3 = 1 M preset
 S1 = multiposition switch
 1 pole/17 way (see text)
 S2,S3 = push button push-to-
 make
 miniature loudspeaker 8 Ω , 1 watt.

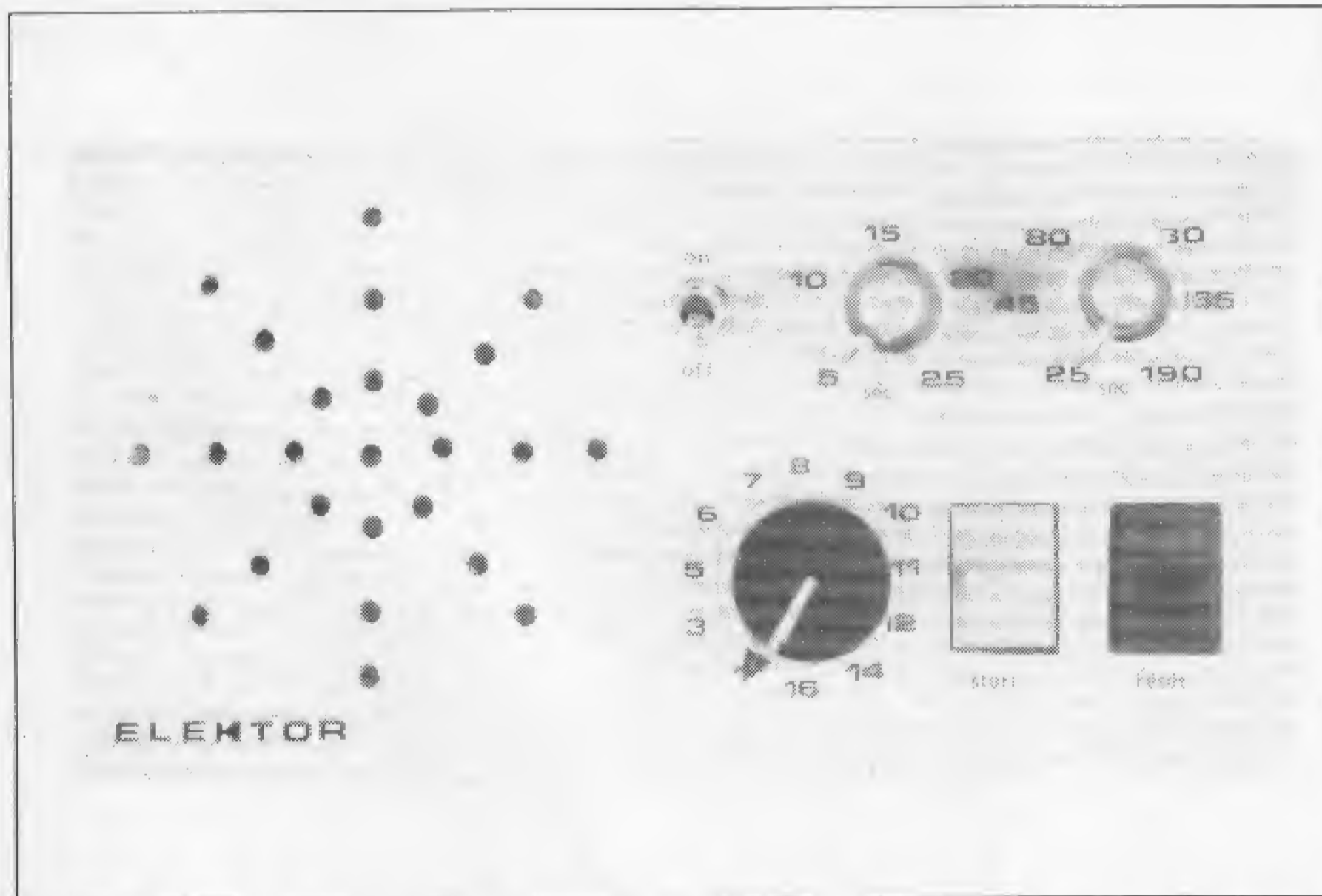

When the clock output goes high, the output of N1 will go low and the audio tone will cease, indicating the period during which the tank is left to stand. When the clock output again goes low the output of N1 will go high, the audio tone will sound and the counter will advance one step. (Note that this does not happen when the start button is pressed due to the reset pulse being applied).

This sequence continues until the counter output that is selected by S1 goes high. A control voltage will be applied to the CCO via R11 and D11. As R11 is smaller than R12 the control current will be higher than that supplied

via R12, so the audio tone will be higher than that sounded during the agitation periods, thus indicating the end of development.

Via D8, the input of N4 is also taken high, so the output will be low, resetting flip-flop N2/N3 and inhibiting the clock. The audio tone will continue to sound until the reset button is pressed, which resets the counters by taking the reset inputs high via D10, or until the start button is pressed, which resets the counters as previously described and starts the clock.

The reset button can also be used to terminate the timing sequence prematurely. If it is pressed during the devel-

opment time, then, in addition to resetting the counters, it will also reset flip-flop N2/N3 via D7 and N4, thus inhibiting the clock.

Construction

A printed circuit board and component layout for the timer are given in figure 4. As the current consumption of the circuit is fairly low (a few milliamps except when the audio tone is sounding) it can be battery powered, which is obviously desirable for safety reasons in a darkroom. If a 17-way switch for S1 proves difficult to obtain, then a 2-pole 9-way switch and an SPDT switch may be used as shown in figure 5.

4

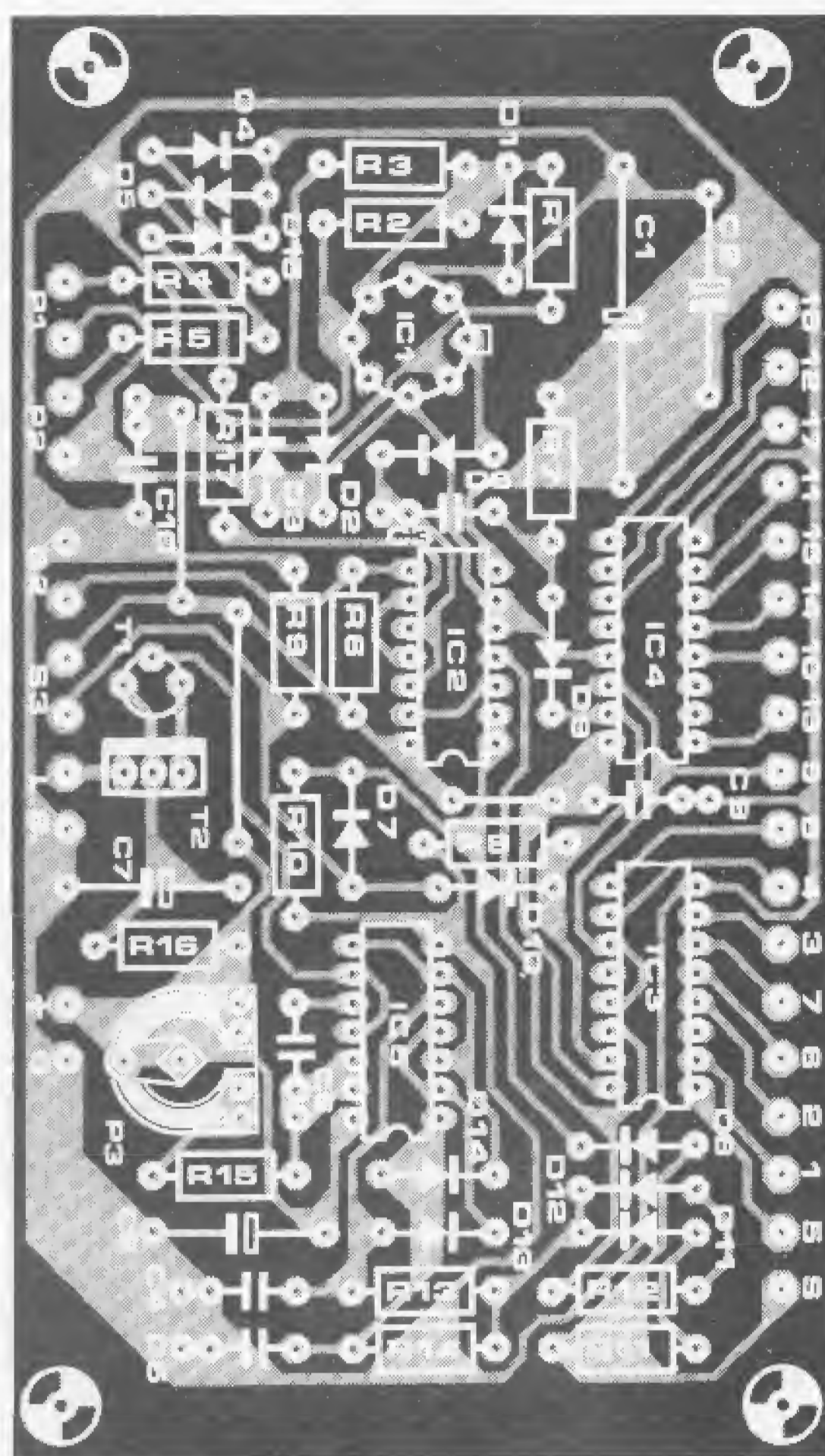
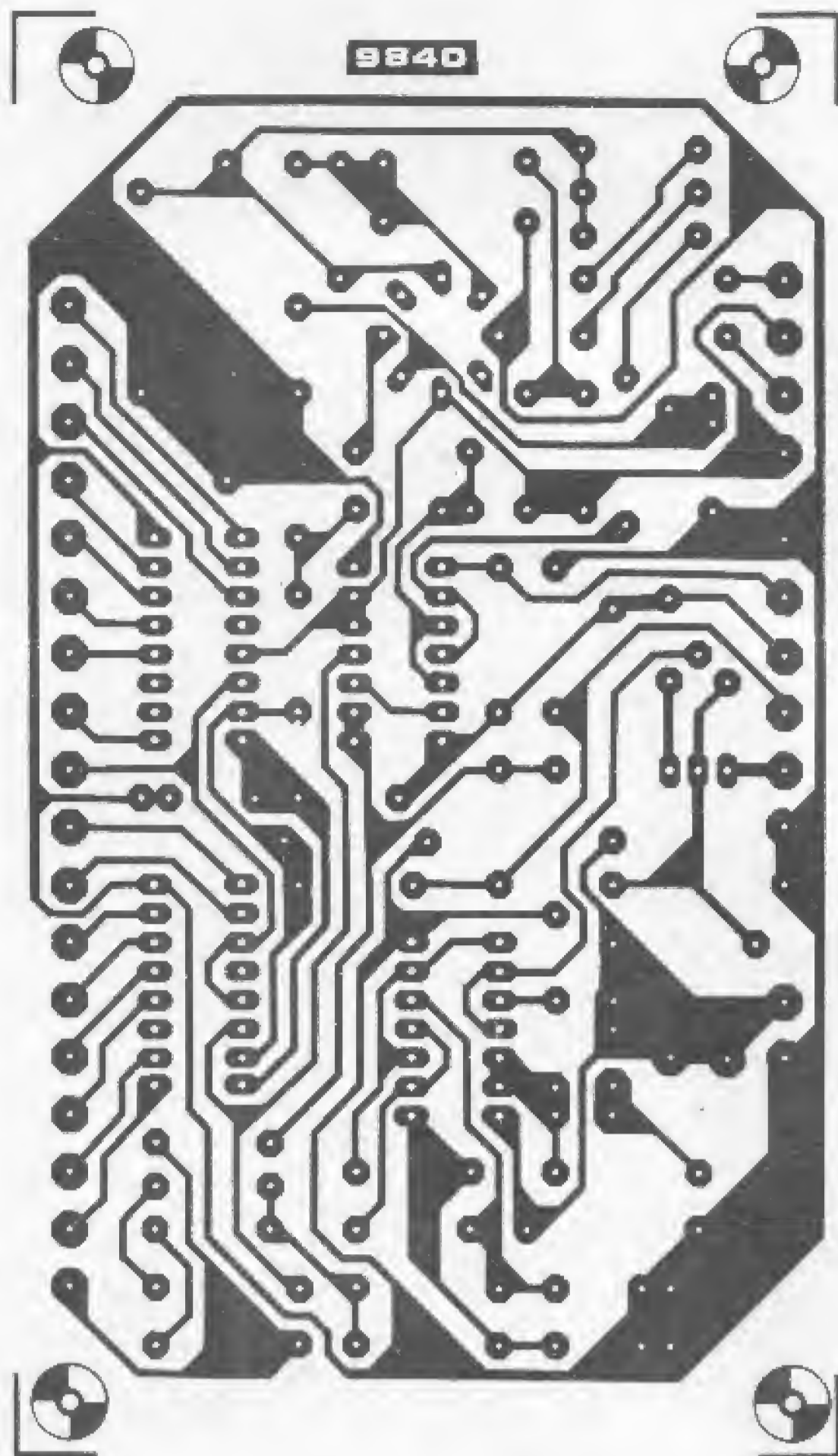

5

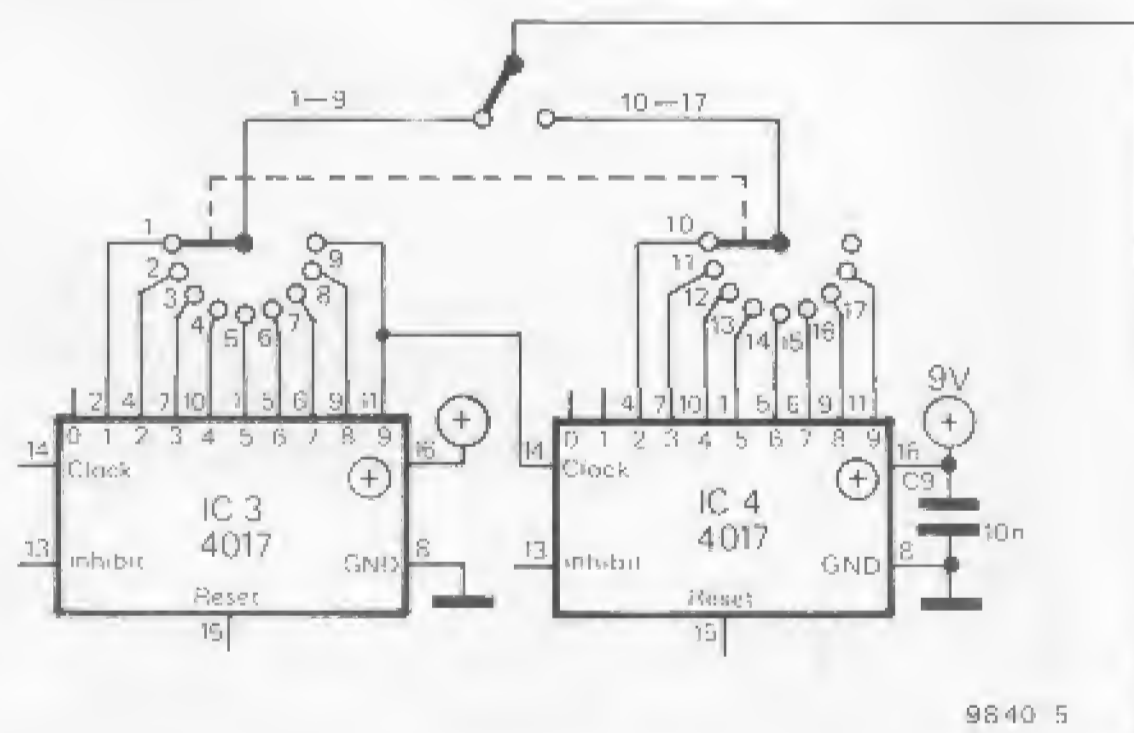

Figure 3. Timing diagram for the development timer, showing the timing sequence with S1 set to position 2.

Figure 4. Printed circuit board and component layout for the development timer (EPS 9840).

Figure 5. If a 17-way switch is unobtainable, then a 2-pole 9-way switch and SPDT switch may be used as shown here.

Calibration

Calibration of potentiometers P1 and P2 must be carried out fairly carefully, since this will determine the accuracy of the entire timer.

First of all a rough check should be carried out with P1 and P2 in their extreme positions to see if the desired range of timing intervals is covered. If not then C1 and C2 can be increased or decreased to lengthen or shorten the intervals covered by P1 and P2. Using a stopwatch, the timing intervals produced at several points around the scales of P1 and P2 should be measured. These points can then be calibrated and the

rest of the scale filled in accordingly. Finally, the volume of the audio tone can be set using P3.

When using the timer, it should be remembered that the time period between the start of one agitation cycle and the next is made up of two time intervals: the time for which the tank should be agitated (set by P2), and the time for which the tank is left to stand (set by P1). To set the timer, P1 and P2 are first adjusted to the correct time intervals and S1 is then set to the count required to give the total development time. Thus, if it was necessary to develop for three minutes, agitating for 10 seconds in every 30, P1 would be set to 20 sec-

onds, P2 would be set to 10 seconds, and S1 would be set to six to give 6 x 30 seconds = 3 minutes.

Before using the timer, it is recommended that it be switched on for a several second 'warm-up' period to allow the clock generator to stabilise.

Final note

A small modification can be added to further improve the accuracy of the first (agitation) interval. A 47 k resistor connected between the anode of D15 and ground will limit the maximum voltage at this point to about two-thirds supply.

experimenting with the SC/MP (4)

Until now the only method of transferring data to and from the SC/MP system has been via the display LEDs and the address and data switches on the RAM I/O card. This has involved converting hexadecimal data and addresses into their binary equivalents, then setting these up, bit for bit, on the appropriate switches — a procedure which is extremely time-consuming, and also greatly increases the chance of entering a bit falsely. With a hexadecimal input/output however, each hexadecimal digit has its own key and the entered digit is displayed directly on a seven-segment display.

The hardware for the HEX I/O consists of separate input and output circuits.

Hexadecimal input

The keyboard is composed of 24 push-button switches (see figure 1), 16 of which are reserved for the hexadecimal digits 0...F, whilst the remaining 8 switches (S1...S8) are used as command keys. A command key can be used to make the microprocessor execute a specific routine simply by pressing a single switch.

The 24 keys are connected to three octal-to-binary encoders (IC1...IC3). The outputs of two of the encoders are NANDed together, so that the state of all 24 keys can be expressed in 8 bits. These 8 bits are then routed onto the data bus of the SC/MP via tri-state buffers.

The 8-bit code generated by the keyboard can be divided into three subsections (see table 1a). Bits 00...03 identify the hexadecimal digits, bits 04...06 contain the inverted value of the command keys, whilst bit 07 is '0' if no key is pressed.

Table 1b gives three examples of the keyboard code. The left hand column indicates the key which has been pressed and the corresponding code is shown on the right. Only one key should be pressed at a time, since only the code of the 'highest' key will appear at the output if several keys are pressed simultaneously. Keys 8...F have priority over 0...7, which in turn override the command keys.

The outputs of the tri-state buffers

By abolishing the restriction of having to work exclusively in binary code, the hexadecimal input/output unit described in this article considerably increases the ease and speed with which the user can communicate with the SC/MP — providing, of course, that he has a thorough grasp of the relevant software.

H. Kampschulte, H. Huschitt

(IC4, IC5) are enabled (via address logic gates N4...N9) by the address decoder of the CPU card. The keyboard will respond to any address between 17 x 8 and 17 x F, where 'x' can be any value (i.e. 'don't care'). Alternatively, as described in part 3 ('page-address structure'), the address can be located on the first memory page between 07 x 8 and 07 x F.

Hexadecimal output

Figure 2 shows the circuit diagram of the hexadecimal output. Basically, this is a relatively self-contained unit that can store eight hexadecimal digits (and several other symbols) and display them on eight seven-segment LED displays.

Each of the LED displays has its own address, so that the output unit actually has a total of eight (groups of) addresses: 17 x 0...17 x 7 (or 07 x 0...07 x 7), where 'x' again stands for 'don't care'. The last three bits of the address indicate the particular seven-segment display. Thus the address ending ...000 will indicate display 0.

In the circuit, these last three bits are applied to the 'B' input of a multiplexer IC (IC14). When entering new data, this information is passed to the address inputs of a 16 x 8 bit 'scratch-pad' memory (IC15 and IC16). 8 bytes of this memory are used to store the data for the 8 displays, as present on the data bus, during the Negative Write Data Strobe (NWDS).

Having stored the information, the next step is to display it. A clock generator (N36) drives a 4-bit binary counter (IC18), three outputs of which are actually used. These three outputs are connected to the 'A' input of the multiplexer (IC14); when this input is selected (in the display mode) the memory will be scanned continuously and the data for the 8 displays will appear sequentially at its output. At the same time, the three outputs of the counter are decoded by a BCD to Decimal decoder-driver (IC17) and used to enable each of the 8 displays in turn.

The data appearing at the memory output are buffered by the open-collector buffer/drivers N20...N27 and used to enable the segments of the displays. Each bit corresponds to one of the seg-

Figure 1. The circuit diagram of the hexadecimal input.

Figure 2. The circuit diagram of the hexadecimal output.

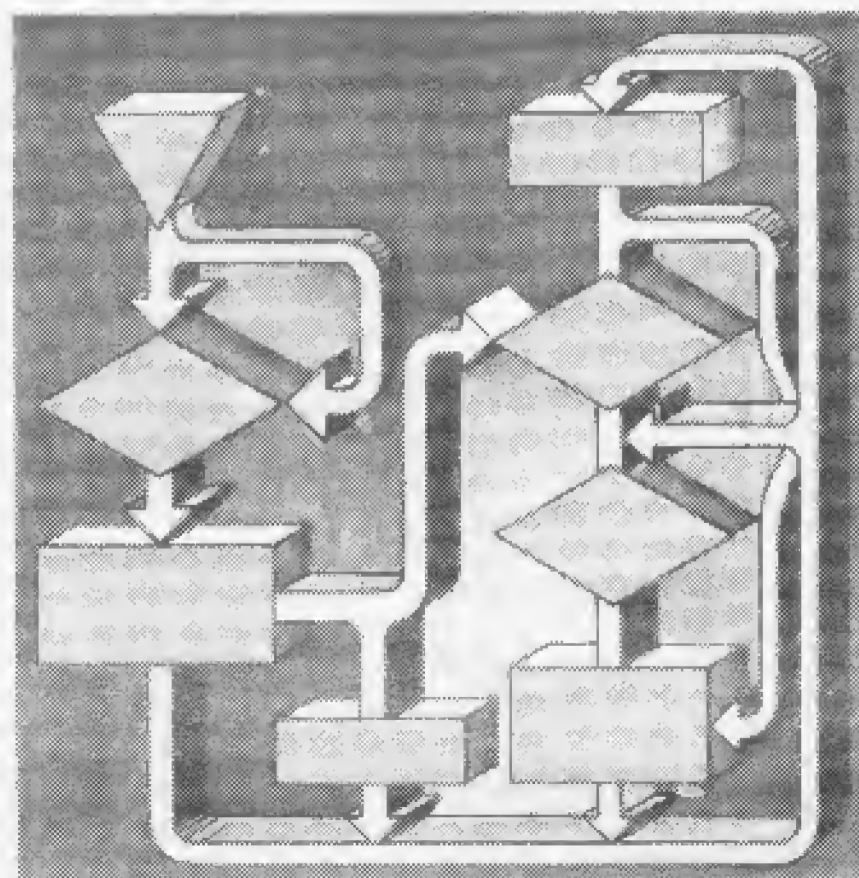

1

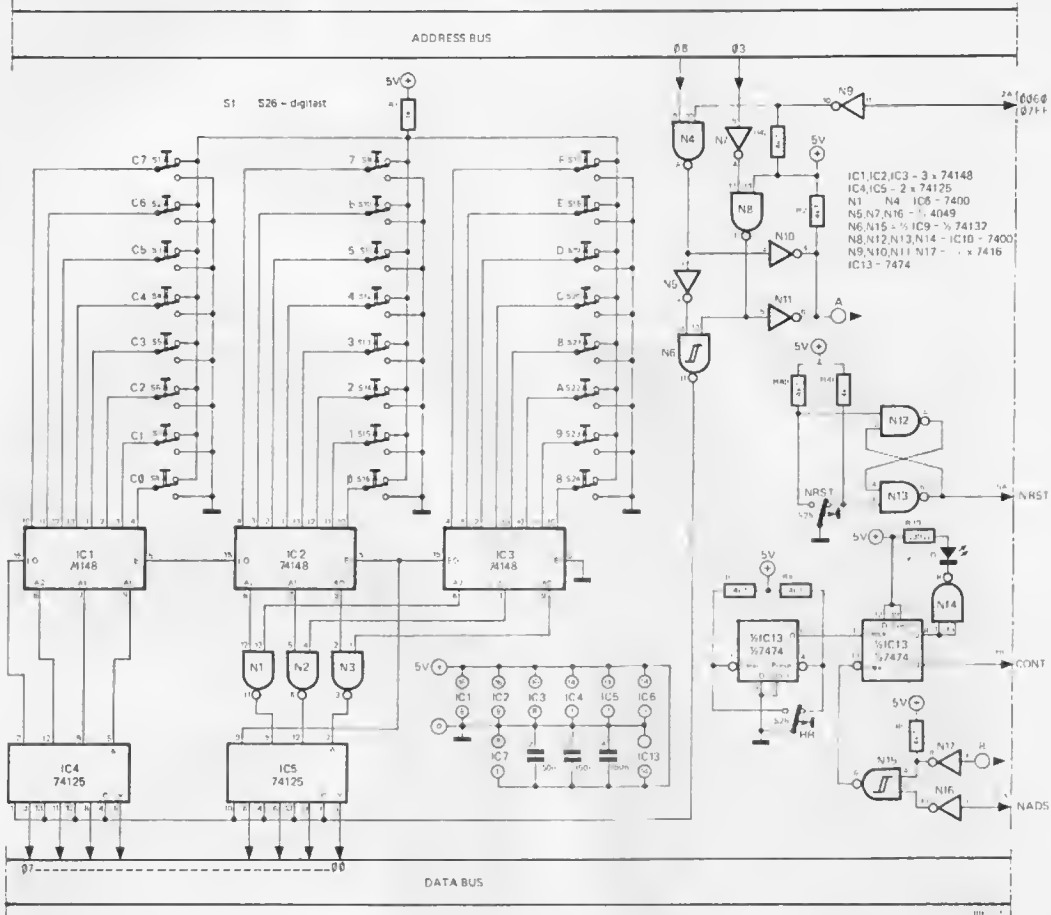

2

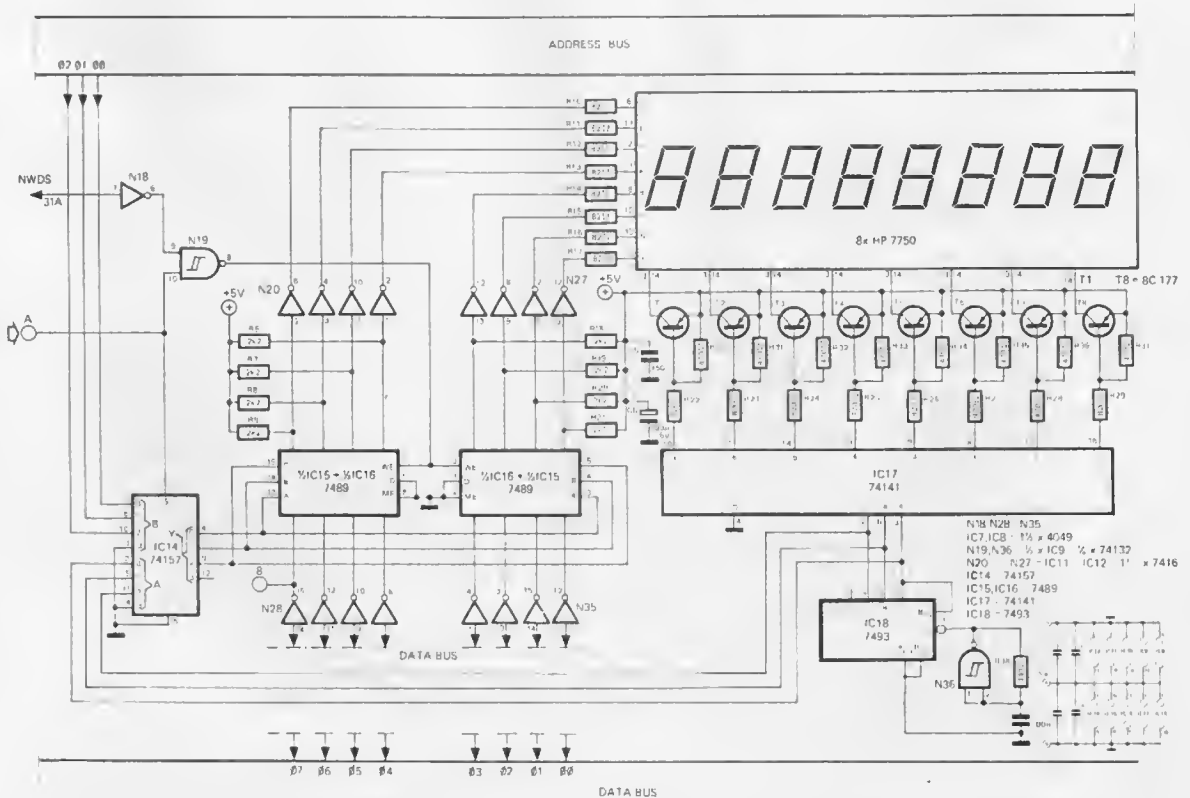

3



Bit	07	06	05	04	03	02	01	00
Segment	d.p.	g	f	e	d	c	b	a

9863.3

Figure 3. This figure shows which display segments are enabled by which bits of the data byte.

Figure 4. This figure shows the track patterns and component layouts of the top (4a and 4b) and bottom (4c and 4d) sides of the HEX I/O printed circuit board (EPS 9893).

ments, as shown in figure 3, so no further decoding is required. If, for example, data bit 00 is a '1', then segment 'a' lights up. The data-byte 01110110 would enable segments b, c, e, f and g, resulting in the letter 'H' being displayed (note that the binary number should be 'read' from right to left, so that the extreme right-hand digit corresponds to segment 'a!'). In this way any desired symbol can be represented on the displays.

Whilst data is being written into the

4a

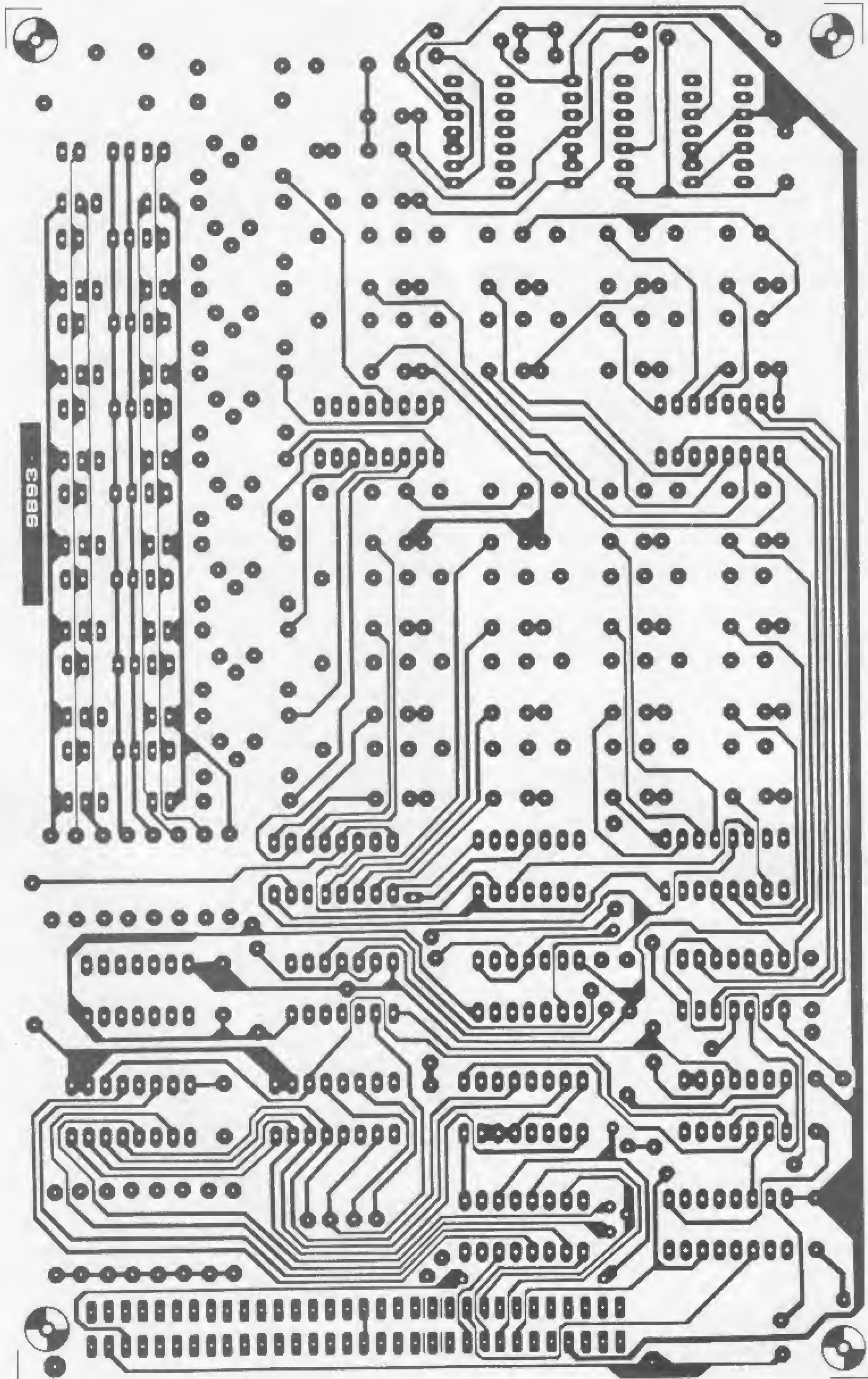

scratch-pad memory the display is randomised. This is due to the fact that the clocked counter (IC18) has no halt facility, thus when the B inputs of the multiplexer (IC14) are enabled, the digit enable is no longer synchronised with the segment drive. However the write-cycle is so short that this effect should be scarcely perceptible.

The printed circuit board

All the components (including the keyboard and display) for both the input

and output circuits are mounted on the same board. As may be seen from figure 1, this board also accomodates the NRST and Halt-reset switches, which means that the SC/MP system can be built without the RAM I/O card. If the RAM I/O card is retained however, then the switches and flip-flops for the above functions can naturally be omitted from the HEX I/O board. The relevant components are: S25, S26, R3, R4, R5, R39, R40, R41, D1, IC13.

To keep its size down to reasonable pro-

Parts list to figure 4b.

- Displays 0 ... 7 = HP-7750
- D1 = LED in S26
- S1 ... S25 = Schadow digitast SPDT
- S26 = Schadow digitast SPDT + LED

4b

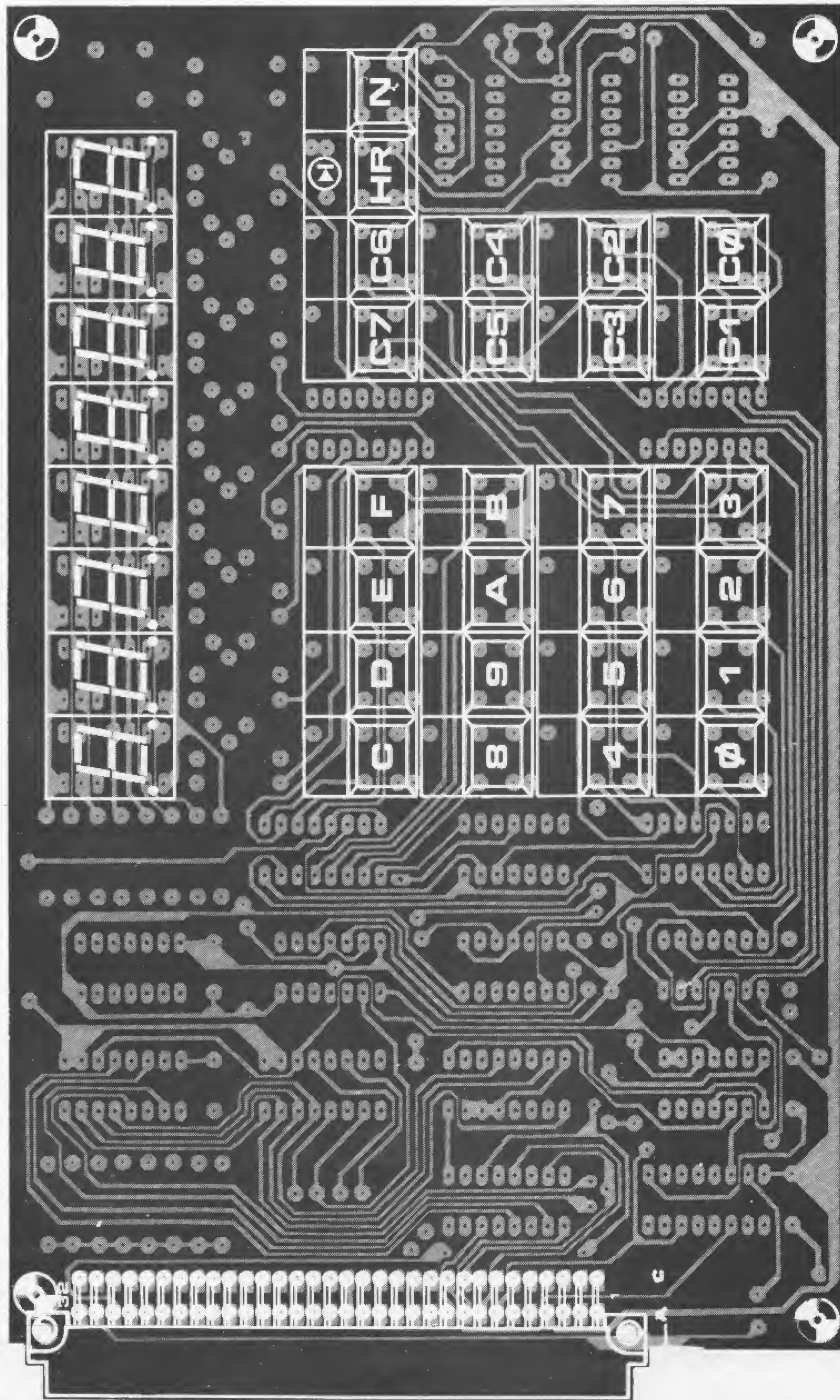

portions, the board is double-sided with plated through holes. Figures 4a and 4b show the track pattern and component layout on the upper side of the board; figures 4c and 4d show the underside. The design of the board takes into account the possibility of mounting the input/output unit in a console or plinth. To this end the upper side of the board (see figure 4b) contains only the keyboard switches, the connector and the displays. Ideally, the displays should then be soldered direct to the board, i.e.

without using connector sockets. The board can be covered with a sheet of red perspex, with a section cut out to allow access to the keyboard. All the remaining components are mounted on the underside of the board (see figure 4d). All connections to and from the HEX I/O board (including those to the busboard) are made via connectors. Figure 5 shows the details of the wiring between the HEX I/O board and the bus board. The connections shown as dotted lines should only be made if the

RAM I/O card is omitted.

Power supply

Before starting on the software, it is important to make sure that all hardware is operating satisfactorily. This will not always be the case if the supply voltages are not accurately maintained. All supply voltages should be within 5% of the nominal values, and this is particularly the case if SC/MP II is used ($V_{CC} = 5\text{ V} \pm 5\%$). Note that this voltage should be present at the pins of the IC!

4c

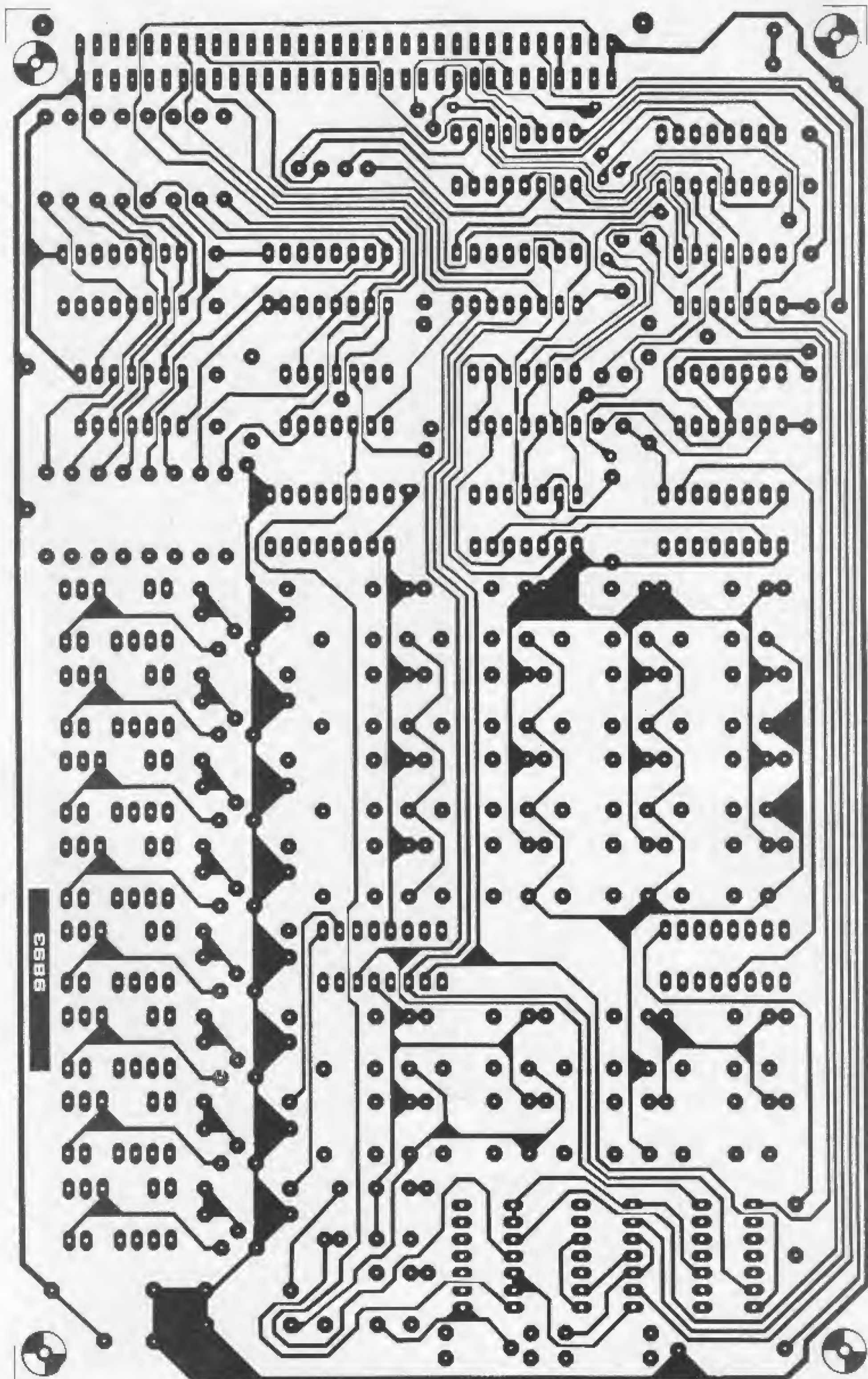

Even if the output of the power supply itself is within the tolerance, a voltage drop in (excessively) long supply lines may just be sufficient to reduce the voltage at the IC to below the minimum required for reliable performance. In case of doubt, it is advised to check the supply voltages at the pins of the ICs. Next month we hope to publish a suitable power supply for the SC/MP.

I/O software

In contrast to the RAM I/O card, the

Parts list to figure 4d.

Resistors:

- R1 = 1 k
- R2 ... R5, R40 ... R42 = 4k7
- R6 ... R9, R18 ... R21 = 2k2
- R10 ... R17 = 82 Ω*
- R22 ... R29 = 820 Ω
- R30 ... R37 = 470 Ω
- R38, R39 = 330 Ω

Capacitors:

- C1 ... C5,

- C7 ... C10 = 100 ... 150 n
- C6 = 100 μ/6 V (tantalum)

Semiconductors:

- IC1 ... IC3 = 74148
- IC4, IC5 = 74125
- IC6, IC10 = 7400
- IC7, IC8 = 4049
- IC9 = 74132
- IC11, IC12 = 7416 (7406)
- IC13 = 7474
- IC14 = 74157
- IC15, IC16 = 7489

- IC17 = 74141
- IC18 = 7493
- T1 ... T8 = BC177 or equ.

* If greater display brightness is required, the value of R10 ... R17 may be reduced to 47 Ω.

4d

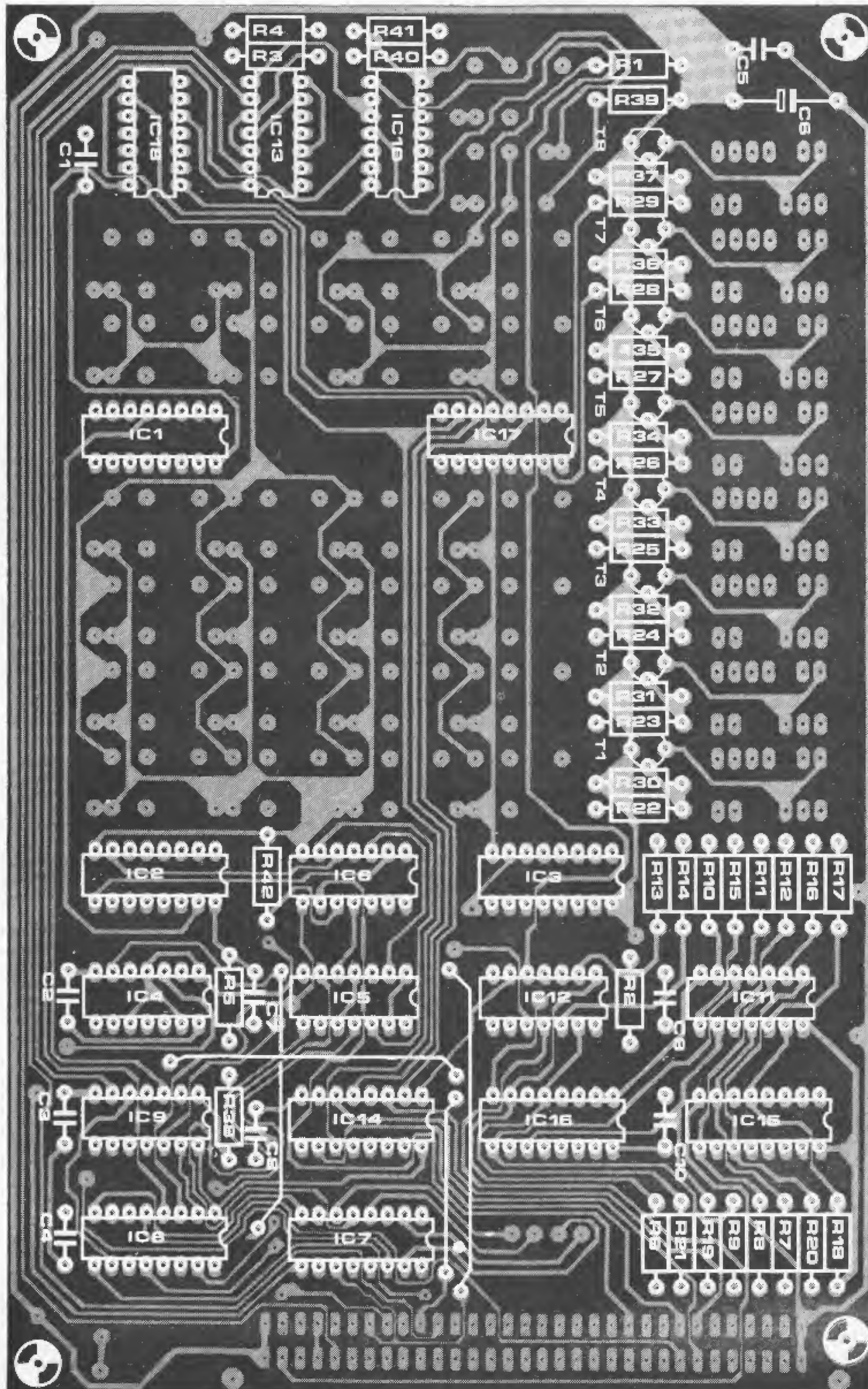

5

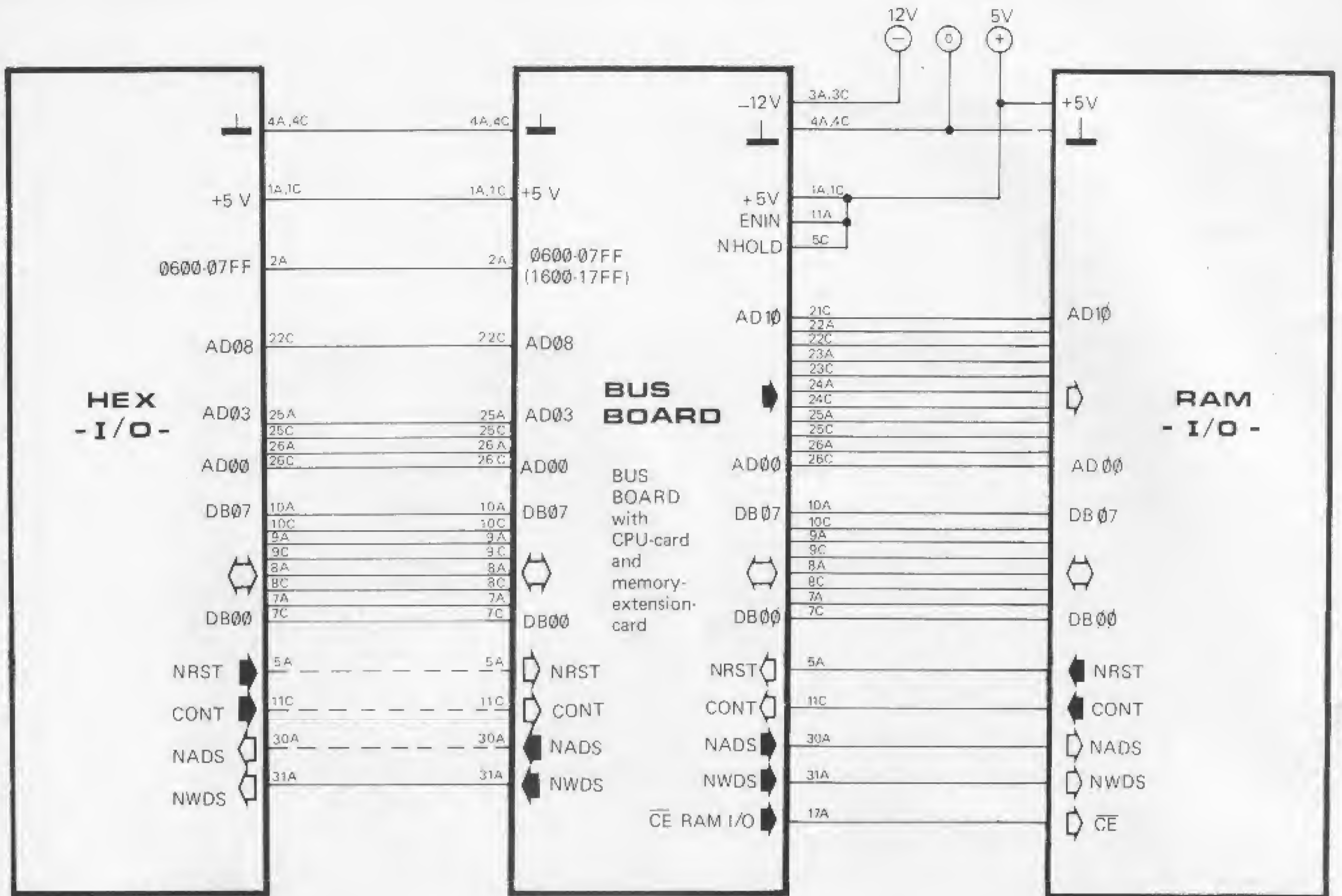

9863 5

Table 1a.

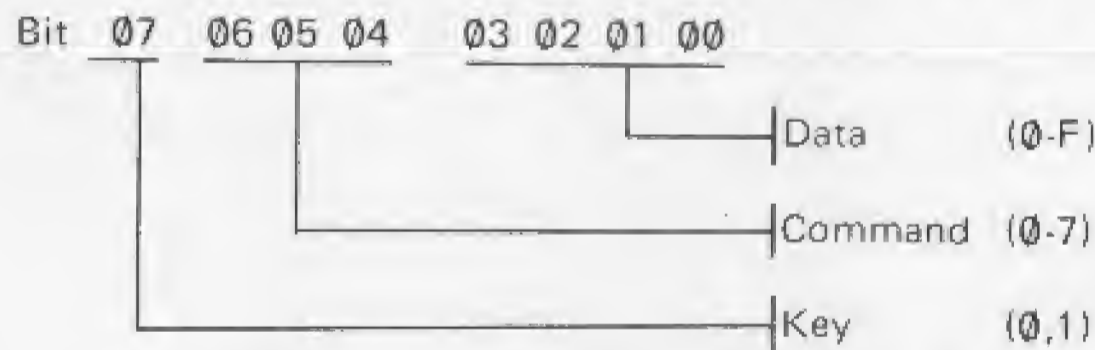

Table 1b.

	Code	
	01110000	(70)
Command	3	11000000 (C0)
Data	C	11111100 (FC)

Table 2.

START = 0000			
0000	08	NOP	
0001	C417	LDI 17	; load PTR 1 with address
0003	35	XPAH 1	; of output
0004	C400	LDI 00	; load data for display 5
0006	C905	ST 5 (1)	; into display memory
0008	C454	LDI 54	; load letter 'n' for
000A	C907	ST 7 (1)	; display 7
000C	C45C	LDI 5C	; load letter 'o' for
000E	C906	ST 6 (1)	; display 6 and
0010	C901	ST 1 (1)	; display 1
0012	C479	LDI 79	; 'E' for
0014	C904	ST 4 (1)	; display 4
0016	C450	LDI 50	; etc.
0018	C900	ST 0 (1)	
001A	C902	ST 2 (1)	
001C	C903	ST 3 (1)	
001E	00	HALT	
		• END	

hexadecimal input/output requires the assistance of a certain amount of software to perform its task. As far as the output section is concerned, this is relatively simple. To transfer the required data to a particular display a 'STORE' instruction is used. The displacement value of this instruction determines which display is addressed.

In the example shown in figure 6, the letter 'P' is to be displayed on display 3. In this case the effective address is calculated using indexed addressing via PTR 1.

Table 2 lists a programme which will also test the hardware involved. This programme, which must be loaded into the RAM of the RAM I/O card, will display the words 'no Error'.

A second example programme which will display a well-known name is listed in table 3.

The software required to interrogate the keyboard is somewhat more complicated. Figure 7 shows the flow-diagram for the simplest possible programme which allows the state of the 16 data keys to be tested. After the start of the programme, the 8 bits of keyboard data are loaded into the AC. This continues until bit 07 is '1', thereby indicating that a key has been pressed. Before the keyboard data is further processed, a delay instruction is executed to ensure the data is valid (i.e. allow for contact bounce).

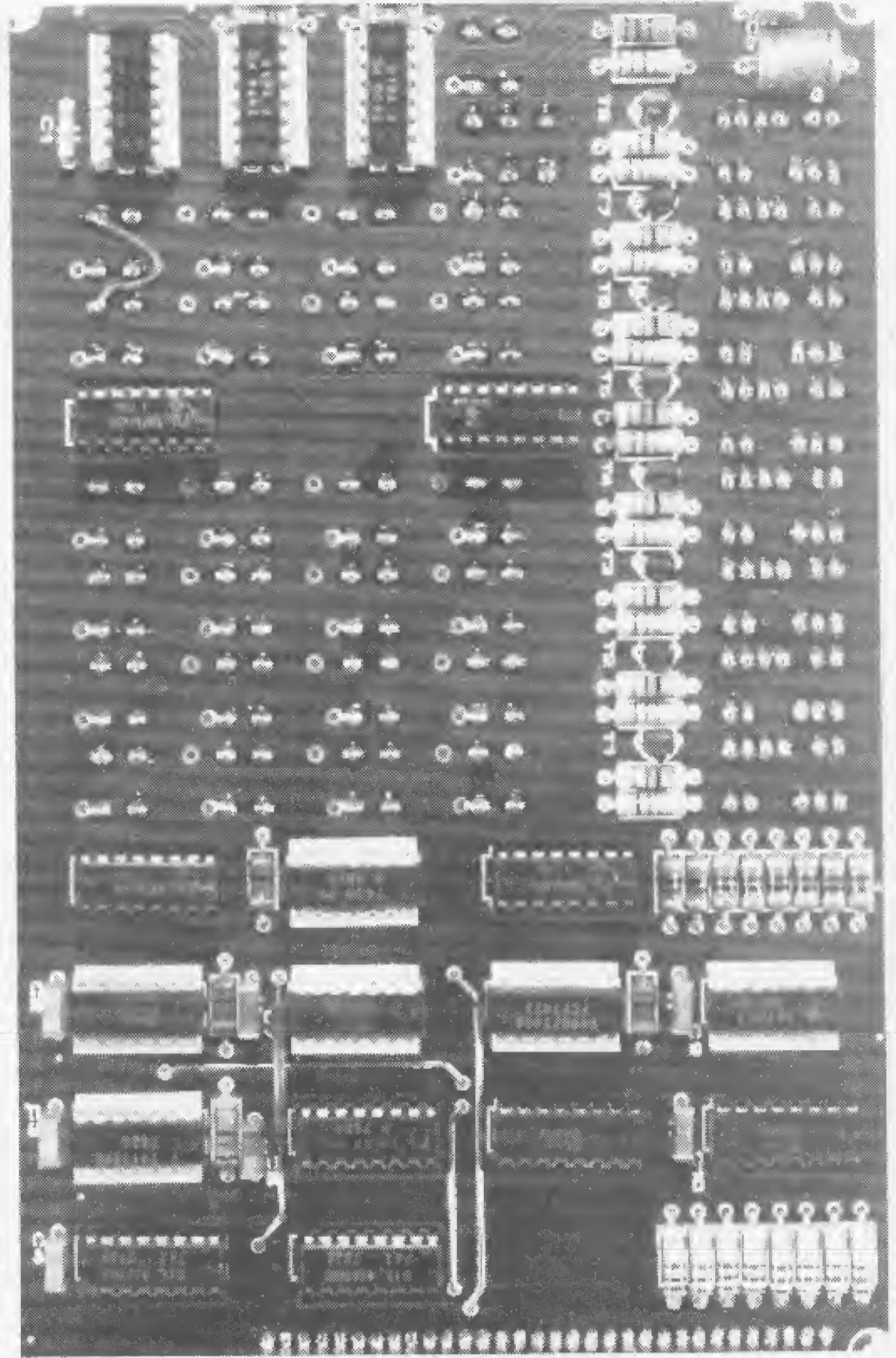
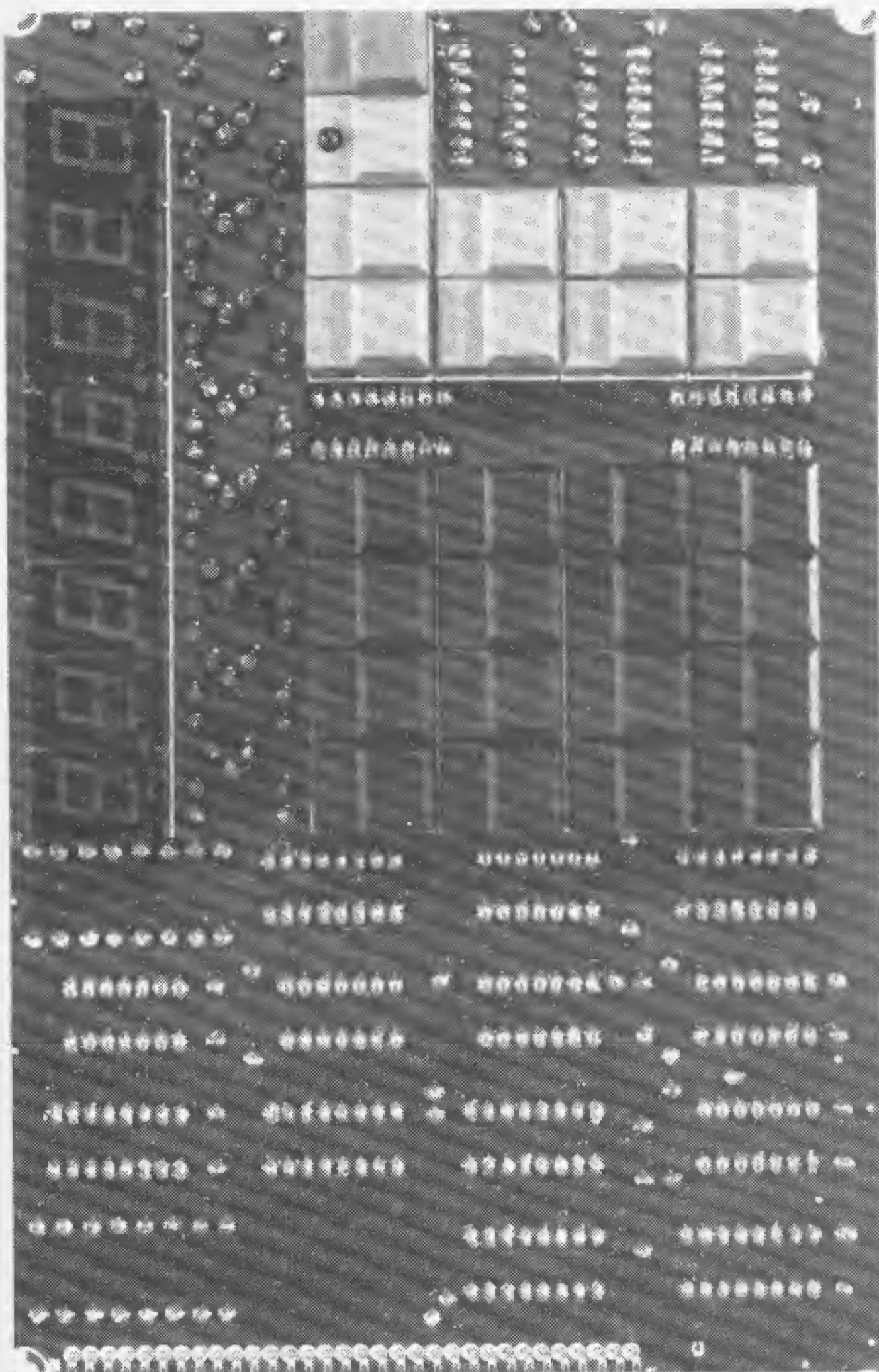

Since only the state of the data keys is to be tested, the AC is first masked by 0F, after which the new contents of the AC are stored in memory. The state of data-bit 07 is tested once more, and so on until it is '0' (the key is released), upon which a second delay instruction follows. The cycle may then be repeated if so desired.

A slightly more complicated demonstration programme which will display the contents of the data keys on the readout is listed in table 4. Once the programme has been loaded into the RAM on the RAM I/O card and started by operating the NRST switch, pressing one of the data keys, e.g. key A, will result in the letter A appearing on display 0. If then key B is pressed, the letter B will appear on the next display, and so on until all 8 displays are enabled. The programme can then be repeated by operating the NRST.

The above programme is simply intended to demonstrate the HEX I/O, and cannot in fact do anything apart from display the 'contents' of a data key. The programme which enables the keyboard to perform its true function, i.e. modify the contents of the memory, is given in table 5 (see figure 8 for the flow-diagram). This involves investing a certain amount of time, since the programme, which is 200 bytes long, must be written into RAM using the data switches.

Table 1. This table shows the formats of the 8-bit code generated by the keyboard.

Table 2. This programme will cause the words 'no Error' to appear on the displays.

Table 3. A 'surprise' programme.

Figure 5. The connections between the HEX I/O board and the bus board. The connections which are shown as dotted lines are made only if the NRST and Halt-reset functions on the RAM I/O card are no longer being used.

Table 3.

0000	08
0001	C417
0003	35
0004	C450
0006	C900
0008	C45C
000A	C901
000C	C478
000E	C902
0010	C475
0012	C903
0014	C479
0016	C904
0018	C906
001A	C438
001C	C905
001E	C400
0020	C907
0022	00

Once the programme is started (by pressing the NRST key), the display will show 1E00xx, where 'xx' are the contents of 'address' 1E00. The command key which generates the code 10000000 (i.e. key C0) is the 'NEXT' key. Pressing this key results in 1E01yy appearing on the displays, where 'yy' represent the contents of address 1E01. In this way it is possible to read out the contents of every location of the same page in memory. After 1FFF the displays show 1000 since there is no carry to the 4 most significant address bits.

In order to modify the contents of a memory location, the new data is entered at the desired address by means of the data keys. For example, pressing key A twice, will result in 'AA' being written into the desired address.

If the 'user's programme' is to commence at a start address other than 1E00, then the loader programme should be modified accordingly. Using the data switches, the lower-order byte of the desired start address is loaded into address 0009 and the higher-order byte into address 000C.

Once the user's programme has been loaded into memory, one would normally expect to start it by operating the NRST key. However, since the loader programme precedes the user's programme in the memory, the loader programme must first be modified: it will have to start with an instruction 'jump

6



'P' d,p. g f e d c b a
 0 1 1 1 0 0 1 1 = 73

(PTR 1) = 1700
 Address display 3 = 17x3

```
LDI 73      C473
ST 3(1)    C903
9863 6
```

Figure 6. An example of how a particular symbol, in this case the letter P, is presented on a specific display.

Figure 7. The flow diagram for a simple keyboard routine.

Table 4. The listing for the HEX I/O demonstration programme.

Table 5. The listing for the HEX I/O loader programme.

7

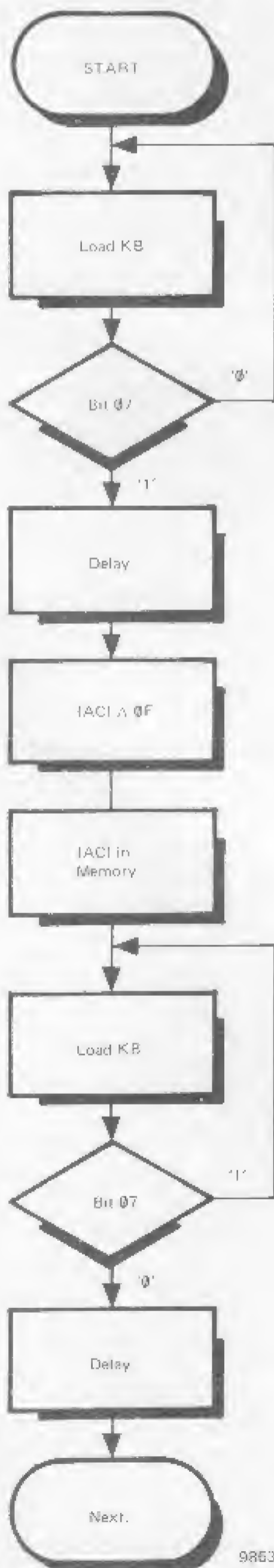

9863 7

Table 4.

```
START = 0000
0000 08  NOP
0001 C408  LDI L (KB)
0003 31  XPAL 1 ; load PTR 1 with
0004 C417  LDI H (KB) ; EA of 'KB'
0006 35  XPAH 1
0007 C400  LDI L (DISPL)
0009 32  XPAL 2
000A C417  LDI H (DISPL) ; load PTR 2 with
000C 36  XPAH 2 ; EA of 'DISPL'

LABEL 1:
000D C100  LD 0 (1) ; load keyboard
000F 94FC  JP LABEL 1 ; bit 7 = 0, no key pressed
0011 D40F  ANI 0F ; mask bits 0 - 3
0013 01  XAE ; in E, indirect addressing
0014 C427  LDI L (TAB)
0016 33  XPAL 3 ; 'TAB' to PTR 3 (higher byte = 00)
0017 C380  LD-128 (3) ; addressing via E
0019 CE01  ST @ 1 (2) ; display 7-segment 'code'
001B 8F0A  DLY 0A ; delay approx 10 msec.

LABEL 2:
001D C100  LD 0 (1) ; wait until key is released
001F 9402  JP DLY ;
0021 90FA  JMP LABEL 2
0023 8F0A  DLY 0A ; delay approx. 10 msec.
0025 90E6  JMP LABEL 1

TAB: ; Table with 7-segment code.
0027 3F  • BYTE 3F, 06, 5B, 4F, 66, 6D, 7D, 07
0028 06
0029 5B
002A 4F
002B 66
002C 6D
002D 7D
002E 07
002F 7F • BYTE 7F, 6F, 77, 7C, 58, 5E, 79, 71
0030 6F
0031 77
0032 7C
0033 58
0034 5E
0035 79
0036 71

• END
```

Table 5.

HEX I/O LOADER

0000	08	NOP		0075	C501	LD @ 1 (1)	; increment PTR 1
0001	9005	JMP START	; programme start	0077	909B	JMP \$1	; jump back without loading
0003	08	NOP				RAM:	; into 'adr'
0004	08	NOP	; space for start routine	0079	00	• BYTE 00	
0005	08	NOP	; of user's programme	007A	00	KBOARD:	; memory storage for keyboard
0006	08	NOP				• BYTE 00	; data
0007	08	NOP		007B	00	P1L:	
		START:				• BYTE 00	; 2 bytes for (PTR 1)
0008	C400	LDI L (ADR)		007C	00	P1H:	
000A	31	XPAL 1	; load PTR 1 with start address			• BYTE 00	
000B	C41E	LDI H (ADR)		007D	00	COUNT:	
000D	35	XPAH 1				• BYTE 00	
000E	C402	LDI L (DISPL)		007E	00	SEGM 7:	; RAM-byte for 7-segment code
0010	32	XPAL 2	; load PTR 2 with EA of display			• BYTE 00	
0011	C417	LDI H (DISPL)	; digit 2	007F	C0FE	\$4:	
0013	36	XPAH 2		0081	CAFF	LD SEGM 7	
		\$1:		0083	40	ST - 1 (2)	data to display '1'
0014	C402	LDI 02		0084	C8F4	LDE	
0016	C866	ST COUNT	; load cycle counter	0086	C4A2	ST RAM	
0018	C4C9	LDI L (TAB)		0088	33	LDI L (LDKB) - 1	
001A	33	XPAL 3	; load PTR 3 with EA of table	0088	33	XPAL 3	
001B	C400	LDI H (TAB)	; for converting binary to	0089	C400	LDI H (LDKB)	
001D	37	XPAH 3	; 7-segment 'code'	008B	37	XPAH 3	
001E	31	XPAL 1		008C	3F	XPPC 3	; to keyboard routine
001F	C859	ST RAM	; fetch lower byte of 'adr'	008D	CAFE	ST - 2 (2)	; data to display '0'
0021	31	XPAL 1		008F	C0E9	LD RAM	
		\$2:		0091	1E	RR	
0022	C40F	LDI 0F		0092	1E	RR	
0024	D054	AND RAM	; mask bits 0 - 3	0093	1E	RR	
0026	01	XAE	; load E for indirect addressing	0094	1E	RR	
0027	C380	LD - 128 (3)	; fetch 7-segment 'code' and	0095	58	ORE	
0029	CE01	ST @ 1 (2)	; store in display, digit 2	0096	01	XAE	
002B	C04D	LD RAM		0097	C0E3	LD P1L	
002D	1C	SR	; bits 4 - 7 of lower byte of	0099	31	XPAL 1	
002E	1C	SR	; PTR 1 (higher byte in second	009A	C0E1	LD P1H	; reload PTR 1 with
002F	1C	SR	; cycle) = 'adr', are shifted	009C	35	XPAH 1	; previous contents
0030	1C	SR	; into bits 0 - 3	009D	40	LDE	
0031	01	XAE		009E	C900	ST 0 (1)	
0032	C380	LD - 128 (3)	; fetch 7-segment code	00A0	3F	XPPC 3	; in 'LDKB' wait for key = '1'
0034	CE01	ST @ 1 (2)		00A1	90CC	JMP \$11	
0036	B846	DLD COUNT				LDKB:	; load keyboard routine
0038	9808	JZ \$3	; 2 cycles completed?	00A3	C408	LDI L (KB)	
003A	35	XPAH 1		00A5	31	XPAL 1	
003B	C83D	ST RAM	; fetch higher 'adr' byte	00A6	C417	LDI H (KB)	
003D	35	XPAH 1		00A8	35	XPAH 1	; load PTR 1 with EA of keyboard
003E	90E2	JMP \$2	; jump for second cycle			\$5:	
		\$3:		00A9	C100	LD 0 (1)	
0040	C400	LDI 00		00AB	94FC	JP \$5	; wait for key to be pressed
0042	CE01	ST @ 1 (2)	; clear displays 6 and 7	00AD	C8CC	ST KBOARD	; keyboard code to memory
0044	CE01	ST @ 1 (2)		00AF	D40F	ANI 0F	; mask bits 0 - 3
0046	C6FA	LD @ - 6 (2)	; reset PTR 2	00B1	01	XAE	
0048	C100	LD 0 (1)	; load contents of 'adr'			\$6:	
004A	D40F	ANI 0F		00B2	8F0A	DLY 0A	; delay approx. 10 msec.
004C	01	XAE		00B4	C100	LD 0 (1)	
004D	C380	LD - 128 (3)	; fetch 7-segment code	00B6	9402	JP \$7	
004F	CAFE	ST - 2 (2)	; store in display '0'	00B8	90FA	JMP \$6	; wait until key is released
0051	C100	LD 0 (1)				\$7:	
0053	1C	SR	; shift (adr) 4 bits to the right	00BA	8F0A	DLY 0A	; delay approx. 10 msec.
0054	1C	SR		00BC	C4C9	LDI L (TAB)	
0055	1C	SR		00BE	31	XPAL 1	
0056	1C	SR		00BF	C400	LDI H (TAB)	; load PTR 1 with EA of 'tab'
0057	01	XAE		00C1	35	XPAH 1	
0058	C380	LD - 128 (3)	; fetch 7-segment code	00C2	C180	LD - 128 (1)	; fetch 7-segment code
005A	CAFF	ST - 1 (2)	; store in display '1'	00C4	C8B9	ST SEGM 7	
005C	31	XPAL 1		00C6	3F	XPPC 3	; jump back for
005D	C81D	ST P1L	; store (PTR 1)	00C7	90DA	JMP LDKB	; new start
005F	35	XPAH 1				TAB:	
0060	C81B	ST P1H		00C9	3F	• BYTE 3F, 06, 5B, 4F, 66, 6D, 7D, 07	
0062	C4A2	LDI L (LDKB) - 1		00CA	06		
0064	33	XPAL 3		00CB	5B		
0065	C400	LDI H (LDKB)	; start 'LDKB' (= keyboard	00CC	4F		
0067	37	XPAH 3	; routine)	00CD	66		
0068	3F	XPPC 3		00CE	6D		
0069	C010	LD KBOARD		00CF	7D		
006B	E480	XRI X'80		00D0	07		
006D	9C10	JNZ \$4		00D1	7F	• BYTE 7F, 6F, 77, 7C, 58, 5E, 79, 71	
		\$11		00D2	6F		
006F	C00B	LD P1L		00D3	77		
0071	31	XPAL 1	; reload PTR 1	00D4	7C		
0072	C009	LD P1H		00D5	58		
0074	35	XPAH 1		00D6	5E		
				00D7	79		
				00D8	71		
						• END	

ELEktor

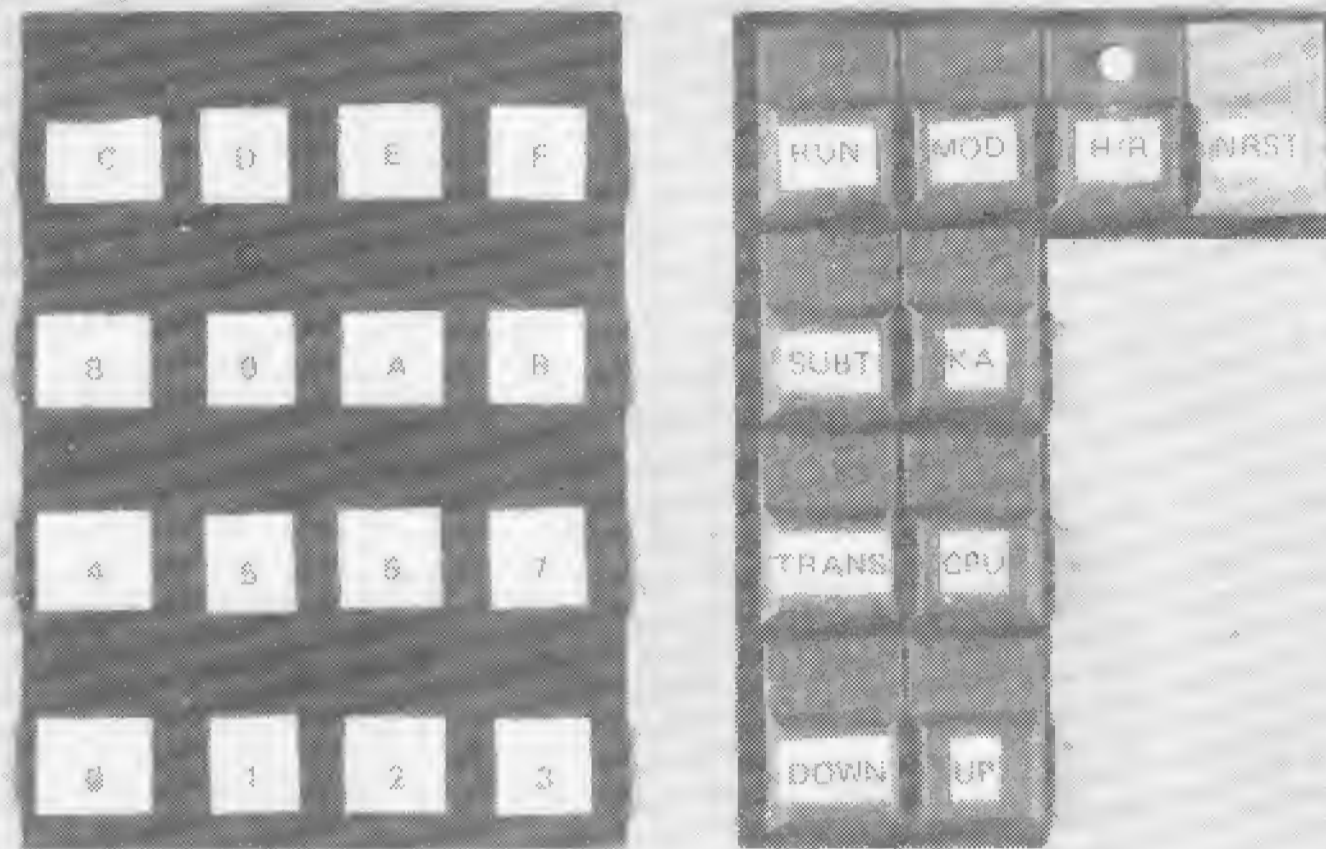

Figure 8. The flow-diagram for the HEX I/O loader programme. See table 5.

Table 6. The start routine.

Table 6.		
0000	08	NOP
0001	C400	LDI 00
0003	33	XPAL 3
0004	C41E	LDI X'1E
0006	37	XPAH 3
0007	3F	XPPC 3

to user's programme'. A suitable start routine is shown in table 6; this routine must be entered (using the data switches) before operating the NRST key to start the user's programme. If a start address other than 1E00 is used, the start routine must be modified accordingly.

In order to be able to use the HEX I/O loader programme again, the beginning of this programme must be restored to its original state.

It must be admitted that the start procedure for the user's programme is slightly awkward. However the alternative would involve further lengthening of the 200-byte loader programme, and without a cassette interface this is not really practical. Once the system is equipped with a cassette interface however, a programme of this length need be keyed into memory once only, since it can then be stored permanently on tape. Details of the cassette interface for the SC/MP will follow in a subsequent article.

8

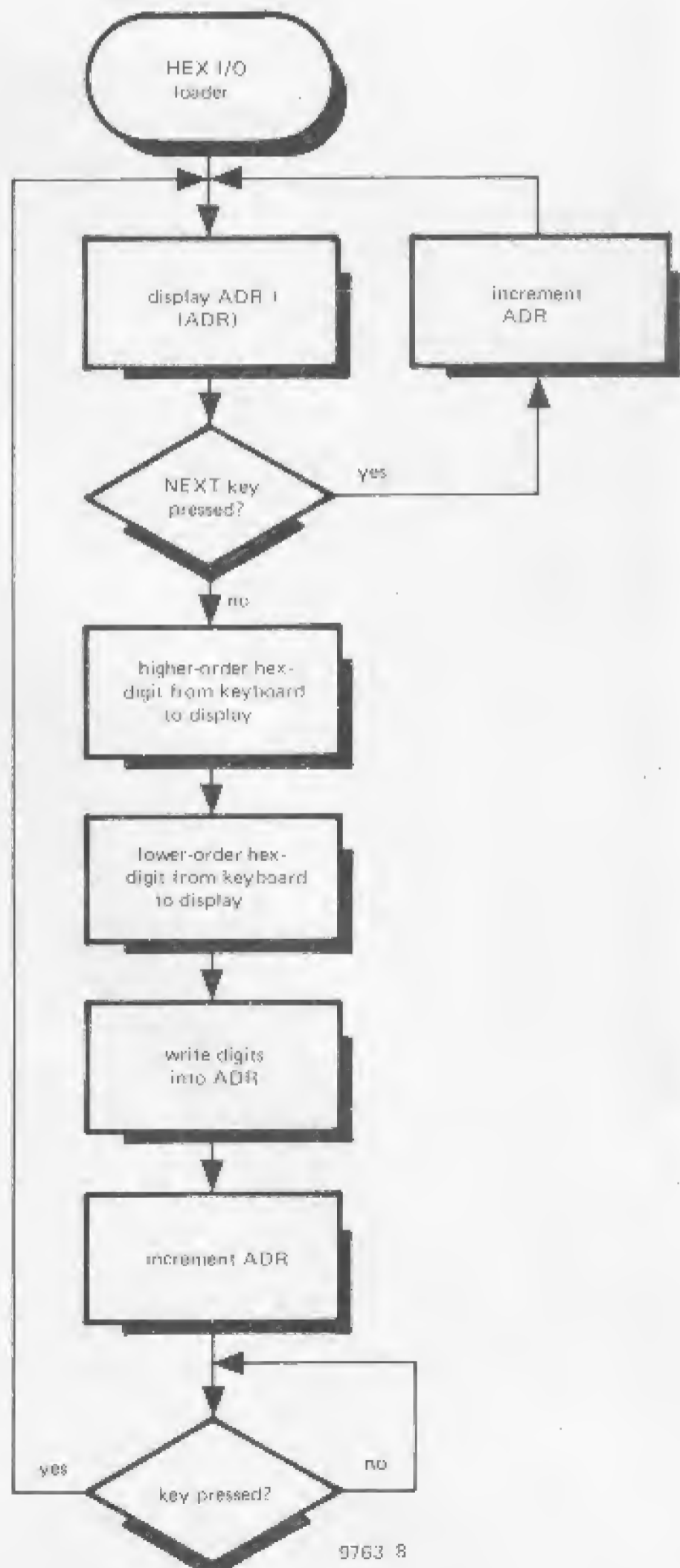

9763 8

Missing link

Experience has shown that the SC/MP II will not always work reliably in combination with the RAM I/O card. The reason is that the SC/MP II has a lower fan-out than the older SC/MP, for which the system was originally designed. The problem can usually be solved by replacing IC4, IC5 and IC14 on the RAM I/O card by their 'low-power' equivalents: 74LS75 for IC4 and IC5, and 74LS00 for IC14. If the problem persists after this modification, several ICs on the CPU card can also be replaced by their low-power equivalents: IC7 = 74LS00 and IC9 .. IC12 = 74LS125.

An extra decoupling capacitor, C7, has been added on the memory card (EPS 9863) — as can be seen in the top right-hand corner of the component layout shown in figure 5 (part 3). The value should be 150 n.



High-speed error measurement system

At a time when high speed digital transmission is beginning to be commercially exploited, Hewlett-Packard has introduced a new 150Mb/s bit error rate measurement system. The 3762A Data Generator and 3763A Error Detector are specifically designed for field evaluation, commissioning and maintenance of digital line and radio equipment. The measurements performed by the system are:

- binary bit-by-bit error detection on binary and coded signals.
- clock frequency offset generation and measurement.

The 3762A/3763A system strikes a fine balance between dedication and flexibility. Thanks to a wide variety of options available, it can be configured to meet the specialised requirements of existing systems such as cable and radio. At the same time, flexibility is retained to meet the developing needs of new systems such as optical fibre. Choices of internal clock frequencies, data formats, interface levels and impedances are available. Key new features of the 3762A/3763A include a $2^{23}-1$ PRBS test pattern and new interface code for high speed systems, input

equalisation for interconnecting cable loss, and zero block injection to check the pattern dependence of systems. Burst gating inputs allow the 3762A/3763A to operate in burst mode for TDMA satellite applications. To extend the capability further, outputs from the 3763A to an external counter, printer and pen recorder allow unattended long term measurements and error distribution analyses to be made.

*Hewlett-Packard Limited
King Street Lane
Winnersh, Wokingham
Berkshire RG11 5AR*

(646 M)

Low cost mini-meters

Componex mini-meters are low cost miniature moving coil indicators designed for use on a wide range of industrial and consumer electronic products. They lend themselves to many applications which require analogue indication, but do not justify the cost of a conventional panel meter. The meters are compact, have a low current drain (from 200 microamps) and incorporate rugged movements which make them suitable for use on portable equipment. Round, rectangular, square and edgewise

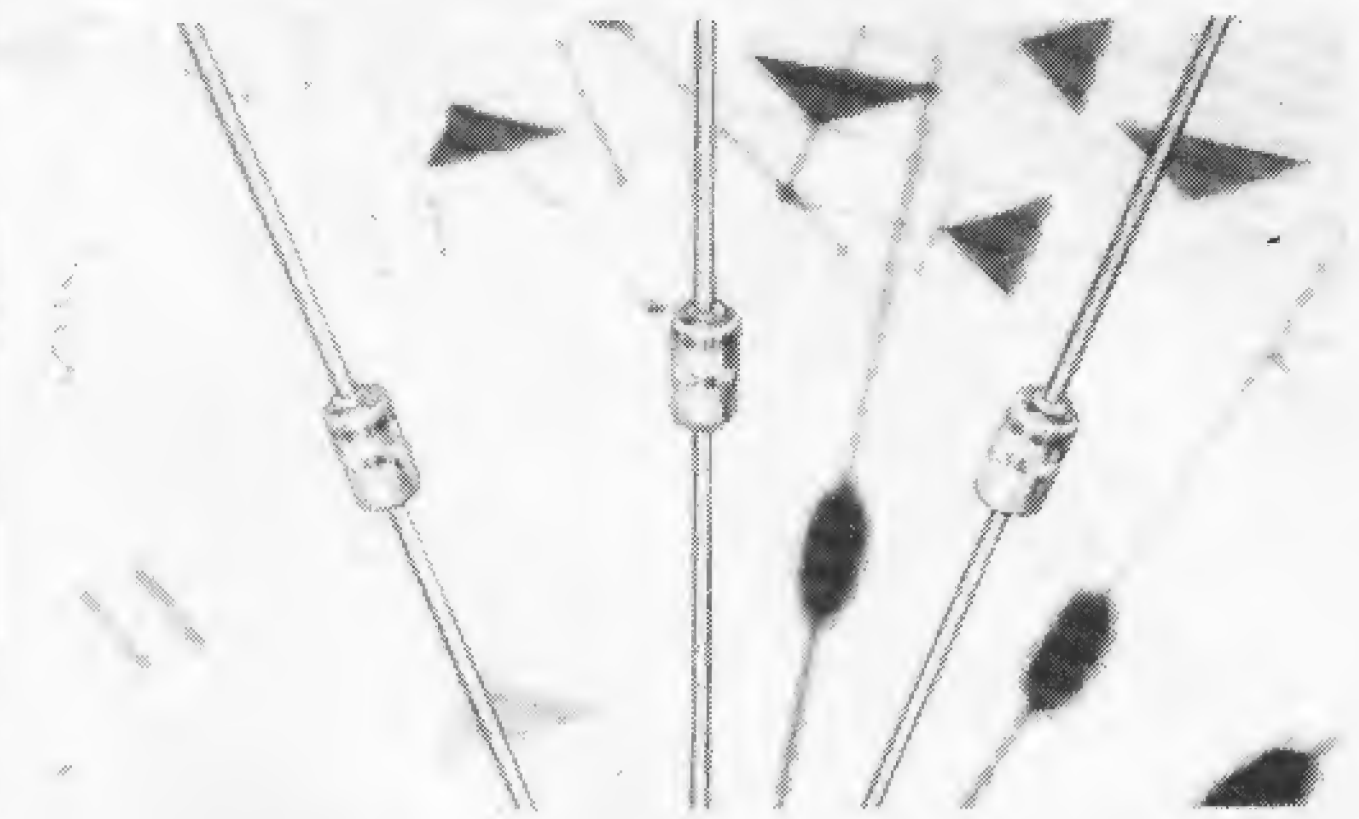

indicator cases are produced in a total of over twenty different types. Large stocks are held of standard models, whilst production quantities with customised scales are produced quickly to special order.

*Componex Limited
48/56, Bayham Place
London NW1 0EU*

(644 M)

Analog shift registers for electronic music applications

AMI have expanded further their broad line of customer and standard MOS/LSI devices for the electronic music field, with the introduction of two new analog shift registers.

Designated the S10110 and the S10111, these new analog shift registers use analog delay elements to provide 185-bit delays. Among the effects achievable with the devices are delaying audio signals, adding an electronic chorus, vibrato or string ensemble, providing reverberation or simulating speaker rotation. The S10110 is the only second-sourced analog shift register available: it is a replacement for the ITT TCA 350. It requires a two-phase symmetrical clock input, and the amount of signal delay depends upon the clock frequency.

Similarly, the S10111 imposes a delay dependent upon the clock frequency. It is designed to save outboard circuitry by requiring only a one-phase clock input.

*AMI Microsystems Ltd.
108A Commercial Road
Swindon, Wiltshire
England*

(642 M)

Low-cost zener diodes

A new range of miniature glass-encapsulated zener diodes, the IR BZX 85 series, is available from SASCO Ltd. The new silicon regulator diodes, which combine a large voltage range with low dynamic impedance at low cost, have a maximum power dissipation of 1.3 W at 25°C. Measuring only 5 mm in length

(excluding leads) by 2.7 mm in

diameter, the BZX 85 series covers voltage ratings from 3.3 to 33 V. Maximum dynamic impedance ranges from 35 Ω at 8 mA for the 33 V version down to 3 Ω at 35 mA for the 7.5 V diode.

The diodes are designed for operation over the temperature range -55°C to +175°C.

*SASCO, PO Box 2000
Crawley
Sussex, RH10 2RU*

(641 M)

Phase-locked oscillators

Now available from Ferranti Limited is their new range of solid-state Phase-locked Oscillators covering the band from 0.5 to 18 GHz.

The Solid State Microwave Group has produced the VPO and VPM series of signal sources designed for telecommunication, radar, telemetry and instrumentation system applications. The VPO series is tuneable over 0.5 to 4.93 GHz and the VPM series over the range 4.8 to 18 GHz, with an output power range of up to 750 mW and a maximum load VSWR of 1.5 : 1.

Features of this range of oscillators include high spectral purity, extremely low AM and FM noise characteristics, high reliability, and ease of field tuning by two simple adjustments using only a VOM.

When locked to an external reference such as a primary standard or synthesizer, the stability of the oscillator is the same as the reference; when using the internal crystal oscillator, the stability can be up to a best of $\pm 0.00036\%$.

The many options available for this range of phase-locked oscillators include the capability to meet the requirements of MIL-STD-461, high or low frequency modulation options, a ruggedised construction, lock limit alarm, and a non-translating tuning shaft.

*Ferranti Limited
Solid State Microwave Group
Microwave House
Leestone Road
Manchester M22 4RN
United Kingdom*

(640 M)

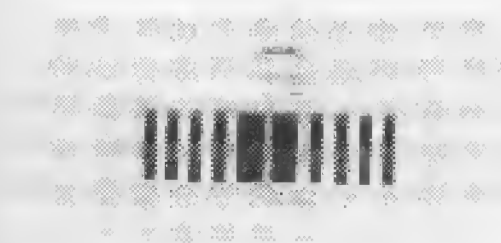
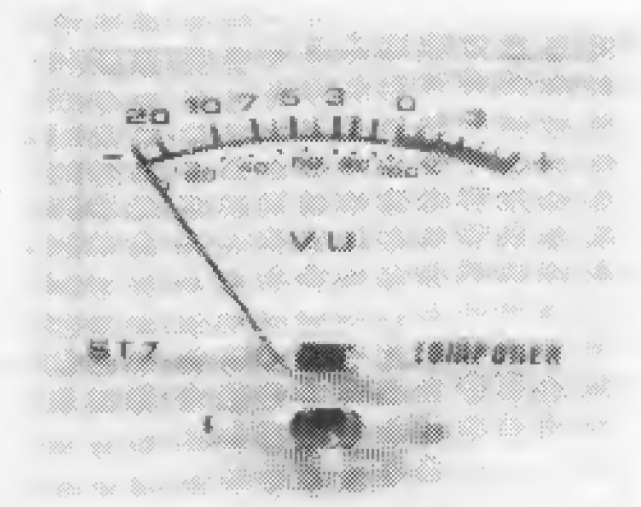
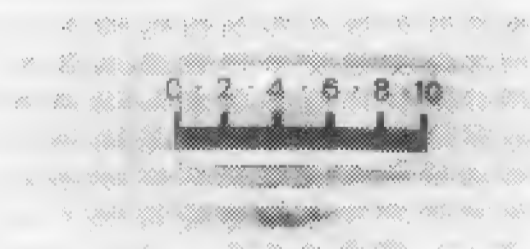

market

General-purpose microprocessor development system

Tektronix U.K. Ltd. announces the availability of a universal microprocessor development system which greatly eases the integration of software and hardware at the prototype stage. Known as the 8000 series Microprocessor Development Lab, the new system is designed for use with several commonly used microprocessors, including the 8080, 6800, Z-80, 9900 and 8085; emulation of other types will follow, and support for new microprocessors will be added as they are introduced.

The availability of a general-purpose microprocessor development tool means that the system designer has only one microprocessor development system to purchase and learn rather than having to purchase one for each type of microprocessor or being committed to a single microprocessor at an early stage. Because the cost of supporting additional microprocessors is minimised, the designer can feel free to choose the microprocessor best suited to his system requirements.

The Tektronix 8000 series is available in two forms: the 8002 Microprocessor Lab, which is a complete stand-alone system; and the 8001 Microprocessor Lab, for users who already have software development capability.

The 8002 is a complete system for developing software and for rapid and convenient integration of the software with the hardware prototype. Interactive entry and editing of the control program is via a visual-display terminal such as the Tektronix CT8100 or CT8101. The 8002 assembles the source code into object code for the microprocessor chosen for the design.

For the designer of microprocessor systems who already has the facility for software development, the 8001 provides a test bed for hardware checkout and for integration of software and hardware. For use of the 8001, programs developed on external stand-alone or time-sharing systems can be downloaded to the 8001 via a RS-232C source.

The key to the versatility of the 8000 series Microprocessor Labs is the in-prototype emulation mode in which the designer runs his program. The emulation subsystem employs the emulated microprocessor type itself, and therefore works exactly like the microprocessor will in the prototype circuit.

Step-by-step checkout of the software/hardware combination is available under debug control via a prototype control probe connected between the Microprocessor Lab and the microprocessor socket of the prototype. The checkout sequence makes use of the Microprocessor Lab's memory resources. A memory

mapping feature allows the memory functions to be transferred, block by block, from the Microprocessor Lab to the prototype as the designer's confidence grows in the input/output portion of the prototype and in the program.

An additional option is the real-time prototype analyser, which allows the program to run in real time while the memory of the Microprocessor Lab captures the data associated with each instruction, together with eight external channels acquired through a separate test probe. The data for the 128 instructions prior to the breakpoint are available for examination. The designer can set breakpoints based on complex conditions involving microprocessor signal lines and external signal lines.

Also available as an option is built-in PROM (programmable-read-only-memory) programming; this option saves time and effort by eliminating the need to transfer the program to another piece of equipment.

The flexibility of the 8000 series Microprocessor Labs to accommodate different microprocessor types results from the use of a multiple-processor architecture. One emulator processor can be replaced by another at any time to accommodate additional microprocessor types, and no additional hardware reconfiguration is required to switch from one development project to another.

*Tektronix U.K. Ltd.
Beaverton House
P.O. Box 69
Harpندن, Herts
England.*

(647 M)

Spade/solder lug for Arrow switch

The Arrow 93 Series of rocker lever switches is now available with 3/16" spade terminals with solder fixing capability. With their 'positive' slow make and break action and international approvals, the 93 Series

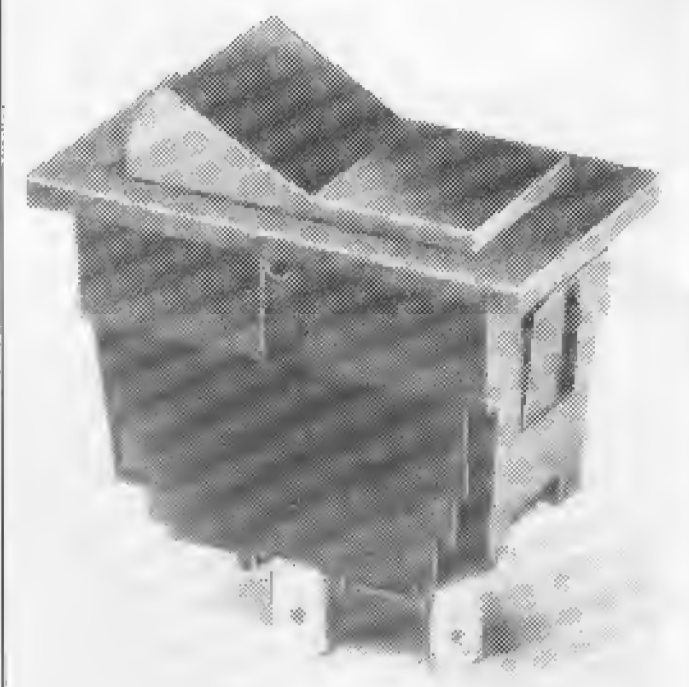

is available with alternative two-hole fixing, illuminated rockers or complementary pilot lights. This new facility extends even further the versatility of this popular series of 'snap-in' switches rated at 10 A 250 V AC (15 A 125 V AC) and limited DC capability.

*Arrow-Hart (Europe) Ltd.
Plymbridge Road, Estover
Plymouth, PL 6 7PN
England*

(639 M)

65k CCD digital memory

Thought to be the first 65k-bit Charge Coupled Device (CCD) digital memory on the market, the F464 from Fairchild is offered at a 'per bit' price that is lower than any other yet available. Further significant price reductions are predicted for the future.

The F464 is a 65,536-bit dynamic serial memory organised as sixteen 4096-bit 'Serial Parallel Serial' blocks in which one bit from any one of the sixteen blocks can be addressed. The company's double-poly N-channel Isoplanar process is used in its fabrication.

Features of the F464 include TTL compatibility on addresses, data input, wire enable, chip select and data output. Its organisation is such that the device can be packaged in a standard 16-pin dual-in-line package. The device operates from 1 MHz to 4 MHz over a temperature range of 0-55°C, whilst power consumption is low; less than 4 μW/bit at 4 MHz active and less than 1 μW/bit at 1 MHz, standby mode.

Data is shifted through the memory by four low capacitance clocks. Three-state output is a feature. Output drive capability of the memory is 100 pF and 3.5 mA into a 100 pF load.

*Fairchild Camera & Instrument (UK) Ltd.
Semiconductor Division
230 High Street, Potters Bar
Herts, EN6 5BU*

(643 M)

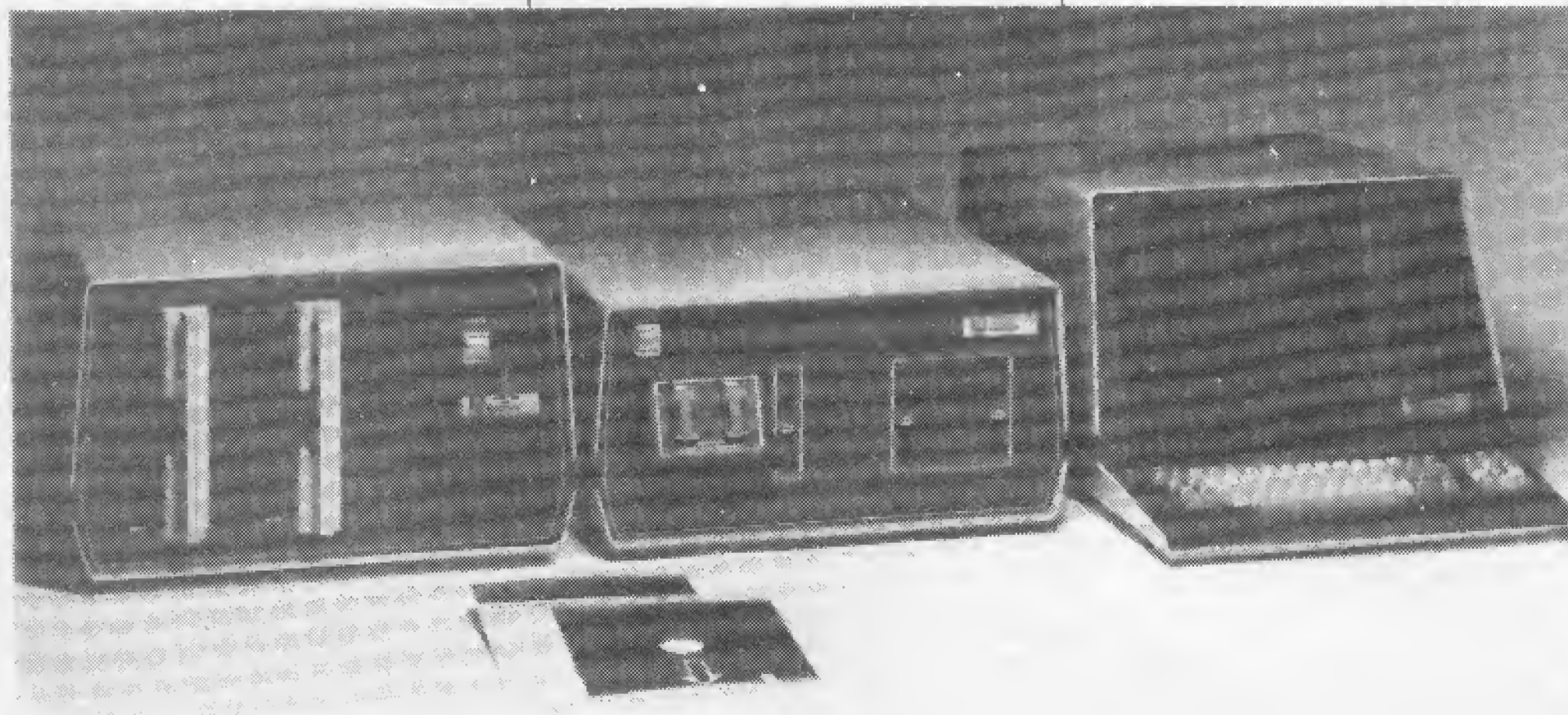

market

Programmable Time and Amplitude Test Set

An unusual programmable time and amplitude test set, the portable 6125C by Ballantine combines four instruments in one package and offers programmability on all front panel functions. The 6125C is a voltage calibrator; a sweep/delay-time or frequency calibrator; a risetime calibrator; and an error indicator. As an oscilloscope calibrator, the user can programme functions such as ranges; divisions of vertical amplitude; marker frequency and the number of

All programming for the 6125C is done with TTL logic or connections to ground. In the programming function, two modes of remote operation are provided. In the first, the programme has full control and cannot be overridden by the panel controls. In the second mode the programme can be overridden locally by the operator via the front panel controls, if the operator wants to repeat or change a test. Then the operator has the option of returning to the programme sequence by re-setting the dials to the remote indication. An adapter card to interface the

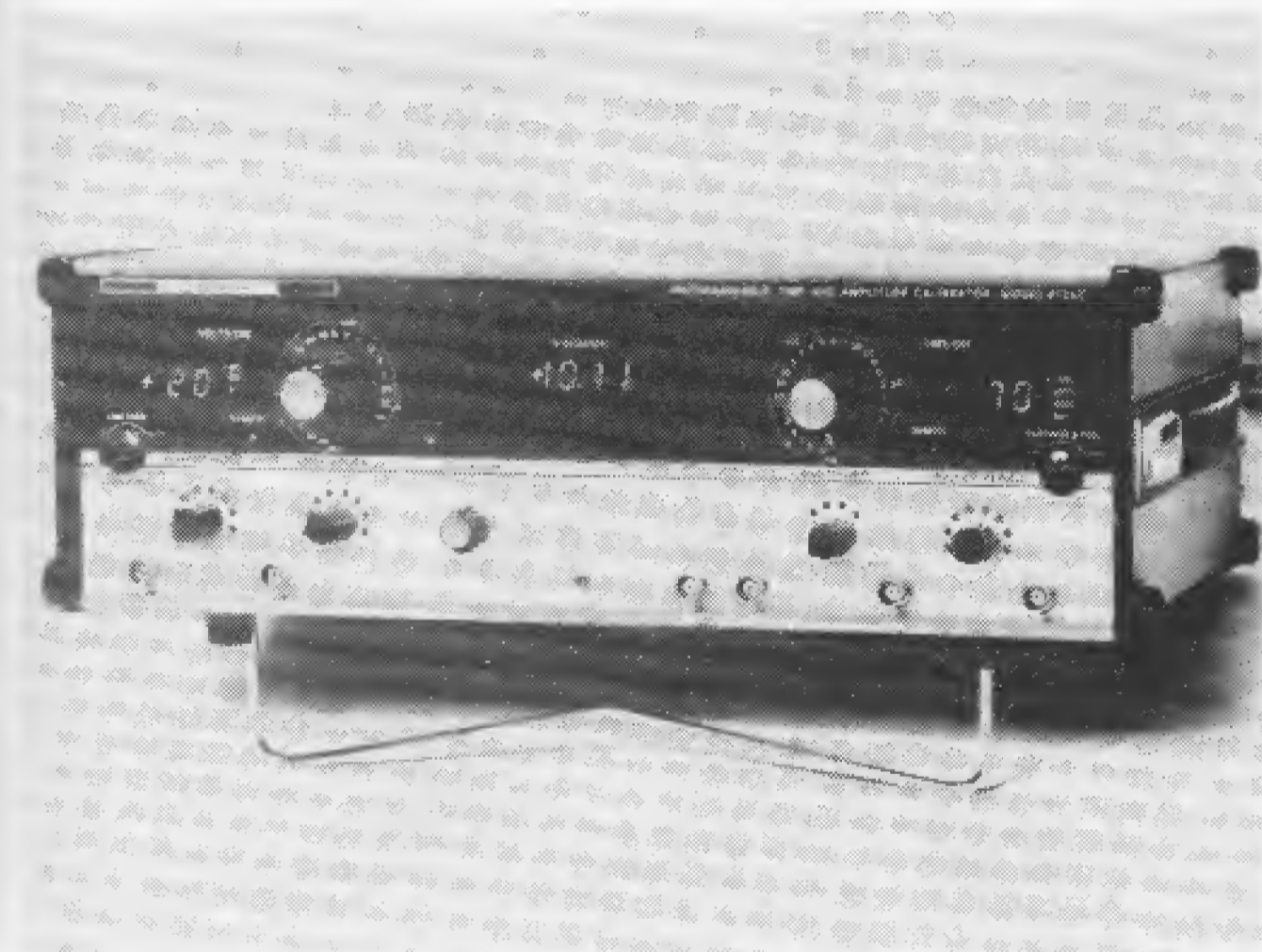

markers displayed; deviation in terms of direct percentage of error in decimals; the rep rate of the fast square used for risetime checks; and either of two modes of remote operation. Retailing at £ 3,160 in the UK, the Ballantine 6125C can check oscilloscopes rated to 500 MHz as well as slow speed scopes, and is also highly suitable for calibrating counters, voltmeters, simple multimeters, panel meters, timers, signal generators and spectrum analysers. The 6125's arrangement of controls and large error display makes the instrument useful for non-technically trained staff calibration checks - particularly at speed - in engineering laboratories, calibration houses, factory test lines, and inspection benches.

6125C to the IEC bus will be available shortly. No calculations are necessary when testing whether an instrument meets specification limits since the large 3-1/2 digit LED readout in the centre of the 6125C panel displays the error of the tested instrument directly, in percentage, with a resolution of 0.01% over a $\pm 10\%$ range. Other features of the instrument include its ability to select square wave amplitude outputs at any frequency from 10 Hz to 10 kHz in decade steps; ability to test high speed scopes with the up to 500 MHz timing stimuli; and the availability of fast square waves with more than 1 nanosecond risetimes at selectable rep rates from 100 nanoseconds to 1 s. As a voltage calibrator the 6125C

provides square waves at four different frequencies: 10, 100, 1000 and 10,000 Hz, crystal derived and accurate to within $\pm .01\%$. Amplitudes are adjustable in steps over an absolute range from 30 microvolts to 220 volts in a 1-2-5 sequence and a nine-position multiplier switch selects whether 1, 2, 3, 4, 5, 6, 7, 8 or 10 divisions high are displayed on the scope screen. Accuracy of the amplitude calibration is better than $\pm 0.25\%$. Principal applications are calibration of oscilloscopes and other instruments or as a quick performance checker.

The 6125C needs only 30 watts at any frequency from 50 to 400 Hz and can be operated from any of the following AC line voltages: 100, 120, 220 or 240 V rms $\pm 10\%$. The instrument is easily portable with dimensions of 16.375 inches x 5.25 inches x 12 inches. Weight is 18 lbs.

*Datron Sales Limited
Penmark House
Woodbridge Meadows, Guildford
Surrey GU1 1BA, England*

(651 M)

High-speed fuses for semiconductor protection

Now available from SASCO Ltd., the IR range of high-speed fuses is specifically designed for the protection of semiconductor devices such as thyristors. Unlike conventional fuses, which incorporate a plain fusible wire element, the high-speed fuses depend for their operation on a pure silver element formed with a series of 'necks' and embedded in silica sand. The result is that when an overload situation does occur the element breaks very quickly, and there is no likelihood of the joint reforming and welding together.

Fuses are available with r.m.s. voltage ratings from 130 V to 700 V over a wide range of r.m.s. currents. Typical maximum I^2t ratings at 250 V range from $26A^2s$ for a 7 A, 250 V fuse to $1.6 \times 10^6 A^2s$ for an 800 A, 600 V type.

*SASCO, PO Box 2000
Crawley
Sussex, RH10 2 RU
England*

(648 M)

Additions to F4000 CMOS family

Two further parts have recently been added to Fairchild's F4000 series of CMOS logic, a family which utilizes the advanced isoplanar C process. These are the F4531, a 13-input parity checker/generator and the F4532, an 8-input priority encoder. The parity checker, F4531, can handle words of variable length. Outputs are fully buffered (active high) and inputs are of the parity type, also active high. With the F4532 priority encoder data is accepted on the priority inputs. The binary code corresponding to the highest Priority Input which is High is generated on the Address Outputs if the Enable Input is High. Both devices are fully cascadable and comply with the new Jedec Industry Standard 'B' Series CMOS specifications. Immediate delivery is available in both plastic and ceramic DIL packages (commercial temperature range) and ceramic DIL packages and Flatpak (military temperature range).

*Fairchild Camera & Instrument
(UK) Ltd.,
Semiconductor Division,
230 High Street, Potters Bar,
Herts, EN6 5BU, England*

(650 M)

